

The McGraw-Hill Companies

3

Third
Edition

DESIGN OF STEEL STRUCTURES



S K DUGGAL

Copyrighted material

Visual Walkthrough



CHAPTER 10

10.1 INTRODUCTION

The design of fundamental structural elements such as compression, tension and flexural members, and also the design of simple connections have been discussed in the previous chapters. In the frame of a steel building, a beam may be attached to another beam or to a column. In such cases, design of connections under a system of loads in the elements primarily depend on an understanding of the behavior of the elements and their connections. The decision of the designer depends upon upon this understanding rather than on sophisticated theoretical analysis. Therefore, a designer should be conversant with the different ways in which a connection can be made between beam or column and beam or beam, and the way it will behave under a given system of loads.

The beam-column connections expected to resist and transfer all moments are termed as rigid connections or fixed connections. These permit free rotation of the beam and do not have any moment restraint. Other type of connections which do not permit any relative rotation between the beam and column and are expected to resist moments in addition to end reactions are termed as moment connections or rigid connections. An example of a 100 per cent rigid connection is a welded moment resistant connection. However, these connections do not behave as desired and are relatively flexible or rigid. A third type of connection which resists and transfers all moments and permits relative rotation between the beam and column is termed as a semi-rigid connection. Actually all beam-column riveted connections are of the semi-rigid type.

The moment-rotation relationship for different types of connections are shown in Fig. 10.1. This is a curve expressing the moment M transmitted by the connection.

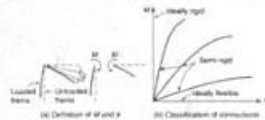

Fig. 10.1 Theoretical Connection Characteristics

Each chapter begins with an **Introduction** that states the purpose and goals of the chapter.

The gradation of **topics** provide a quick look into the concepts involved in the analysis of structural elements.

10.0 Design of Steel Structures

welded construction as discussed in section 5.8. The two prevalent column bases are the slab base and the gusset base.

5.3 SLAB BASE

When the column is subjected to only direct loads, the base can be designed by assuming a uniform bearing pressure from below. For small loads, a steel plate alone can be used to transmit the loads to the concrete pedestal. Such a base plate is called slab base (Fig. 5.2) and is considered to be a pinned base. When the column are subjected to bending moments along with direct forces, angle sections are attached to the flanges of column. These angles are anchored with foundation bolts to the concrete pedestal. Even if the column is subjected to direct force only, minimal angle sections should be provided to keep the column in place, and to resist any tension due to erection and connections. Angles may be omitted if the base plate is shop welded to the column.

Theoretical Considerations

It is assumed that the maximum bending moment occurs at the edge of the column

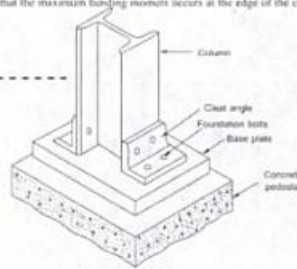

Fig. 5.2 Slab Base

(Fig. 5.3). As the slab tends to bend simultaneously about the two principal axes of the slab, the stress caused by bending about one axis is influenced by the stress due to bending about the other axis.

Taking 1 mm strip of slab projection along $x-x$ axis

$$\text{Maximum bending moment} = w \times l \times a = \frac{w}{2} \times \frac{w l^2}{2} \quad (5.1)$$

Taking 1 mm strip of slab projection along $y-y$ axis

Visual Walkthrough

340 Design of Steel Structures

$$M_x = \frac{2F_c}{4} \left(\frac{L}{2} - \frac{a}{4} \right) = \frac{2 \times 0.75}{4} \times \left(\frac{5.5}{2} - \frac{1}{4} \right) = \frac{6}{55} = 1.09 \text{ kNm}$$

Try ISLC 150 @ 141.3 N/m

$$Z_x = 93 \times 10^3 \text{ mm}^3, Z_y = 20.2 \times 10^3 \text{ mm}^3, C_{rx} = 23.8 \text{ mm}$$

$$\sigma_{b, x} = \frac{M_x}{Z_x} + \frac{M_y}{Z_y} = \frac{2.1818 \times 10^6}{93 \times 10^3} + \frac{1.09 \times 10^6}{20.2 \times 10^3} = 77.42 \text{ N/mm}^2 < 0.66 f_y$$

which is safe.

Exercises

Note Assume the yield stress of steel to be 250 N/mm² of steel specified in the problem.

8.1 Design a simply supported gantry girder to carry an electric overhead travelling crane for the following data.

Crane capacity	320 kN
Weight of crane and crab	300 kN
Weight of crane	200 kN
Minimum approach of crane hook	1.20 m
Distance between c/c of wheels	3.20 m
Distance between c/c of girders	16.0 m
Span of gantry girder	4.00 m
Weight of rails	300 N/m
Height of rails	75 mm
Yield stress of steel	250 MPa

8.2 Design a simply supported gantry girder to be used in an industrial building for the following data.

Crane capacity	100 kN
Weight of crab	35 kN
Weight of crane (excluding crab)	160 kN
Minimum clearance between crane hook and gantry girder	1.00 m
Wheel base	3.00 m
Distance between c/c of girders	20.0 m
Distance between c/c gantry columns	6.0 m
Crane type	M.O.T.

8.3 Two electrically operated overhead travelling cranes are to be used in a bay of an industrial building. Design the gantry girder for the following data:

Crane capacity	250 kN (each)
Bay width	18 m
Spacing of columns	8 m

Exercises for practice are given to prepare students for real-life problems.

Appendix contains important data for design.

Appendices

I ABBREVIATIONS

I.S.B.	Indian Standard Joist Beams
I.S.L.B.	Indian Standard Light Beams
I.S.M.B.	Indian Standard Medium Beams
I.S.H.	Indian Standard Column Section
I.S.W.B.	Indian Standard Wide Flange Beams
I.S.C.	Indian Standard Joist Channel
I.S.L.C.	Indian Standard Light Channel
I.S.M.C.	Indian Standard Medium Channel
I.S.J.T.	Indian Standard Joist Tee Bar
I.S.S.C.	Indian Standard Special Channel
I.S.N.T.	Indian Standard Normal Tee Bar
I.S.H.T.	Indian Standard Wide Flange Tee Bar
I.S.L.T.	Indian Standard Long Legged Tee Bar
I.S.L.T.	Indian Standard Light Tee Bar
I.S.A.	Indian Standard Equal Unequal Angles
I.S.D.A.	Indian Standard Built-up Angle
I.S.H.V.	Indian Standard Rolled Bar
I.S.Q.	Indian Standard Square Bar
I.S.F.	Indian Standard Flat
I.S.P.	Indian Standard Plate
I.S.S.B.	Indian Standard Sheet
I.S.S.T.	Indian Standard Strip

II UNIT WEIGHT OF BUILDING MATERIALS

1. Adhesive cement sheets	120 (in 7.5 m ²)
2. Asphalt	2200 N/m ³
3. Brick	20000 N/m ³
4. Brick work in cement mortar	18000 N/m ³
5. Brick work in lime mortar	16000 N/m ³
6. Concrete	24000 N/m ³
7. Cement mortar	20000 N/m ³
8. Earth	16000 N/m ³
9. Galvanized steel sheet	51.2 to 119.2 N/m ²
10. Glass	18000 N/m ³

Contents

<i>Preface</i>	v
<i>Foreword</i>	ix
1. General Considerations	1
1.1 Introduction	1
1.2 Advantages of Steel as a Structural Material	3
1.3 Disadvantages of Steel as a Structural Material	3
1.4 Structural Steel	3
1.5 Stress-strain Curve for Mild Steel	4
1.6 Rolled Steel Sections	5
1.7 Loads	8
1.8 Dead Load	9
1.9 Live Loads	9
1.10 Wind Forces	9
1.11 Seismic Forces	19
1.12 Snow Load	25
1.13 Earth Pressure	25
1.14 Water Current Load	25
1.15 Impact Load	25
1.16 Permissible Stresses	26
1.17 Working Stresses	26
1.18 Factor of Safety	26
1.19 Minimum Thickness of Structural Members	27
1.20 Design Methods	27
<i>Solved Examples</i>	28
<i>Exercises</i>	32
2. Simple Connections-Riveted, Bolted and Pinned Connections	34
2.1 Introduction	34
2.2 Riveted Connections	34
2.3 Bolted Connections	51
2.4 Pin Connections	56
<i>Solved Examples</i>	58
<i>Exercises</i>	74
3. Simple Connections-Welded Connections	76
3.1 Introduction	76
3.2 Types	77

3.3	Symbols	78
3.4	Welding Process	80
3.5	Weld Defects	81
3.6	Permissible Stresses	82
3.7	Design of Butt Welds	83
3.8	Design of Fillet Welds	84
3.9	Design of Intermittent Fillet Welds	89
3.10	Fillet Welds for Truss Members	90
3.11	Plug and Slot Welds	91
3.12	Failure of Welds	92
3.13	Distortion of Welded Parts	93
3.14	Inspection of Welds	95
3.15	Fillet Weld vs. Butt Weld	95
3.16	Welded Joints vs. Riveted Joints	96
3.17	Selection of Fasteners	96
	Solved Examples	97
	Exercises	105
4.	Compression Members	107
4.1	Introduction	107
4.2	Effective Length	108
4.3	Slenderness Ratio (λ)	110
4.4	Column Design Formula	112
4.5	Types of Sections	113
4.6	Buckling	116
4.7	Design of Axially Loaded Compression Members	117
4.8	Built-up Columns (Latticed Columns)	118
4.9	Lacing	121
4.10	Batten	124
4.11	Compression Members Composed of Two Components	
	Back-to-back	126
4.12	Encased Column	127
4.13	Eccentrically Loaded Columns	128
4.14	Splices	135
	Solved Examples	139
	Exercises	187
5.	Column Bases and Footings	189
5.1	Introduction	189
5.2	Types of Column Bases	189
5.3	Slab Base	190
5.4	Gusset Base	194
5.5	Design of Bases for Eccentrically Loaded Columns	196
5.6	Foundation Bolts	199
5.7	Design of Hold-down Angles	200
5.8	Welded Column Bases	203
5.9	Grillage Footing	205
	Solved Examples	209
	Exercises	223

6. Tension Members	224
6.1 Introduction	224
6.2 Types of Tension Members	224
6.3 Permissible Stresses	227
6.4 Slenderness Ratio (l)	227
6.5 Net Sectional Area	228
6.6 Design of a Tension Member	232
6.7 Lug Angles	234
6.8 Splices	235
6.9 Gusset Plate	235
<i>Solved Examples</i>	237
<i>Exercises</i>	252
7. Beams	254
7.1 Introduction	254
7.2 Types of Sections	255
7.3 Lateral Stability of Beams	256
7.4 Bending Stress	258
7.5 Bearing Stress	267
7.6 Shear Stress	267
7.7 Deflection	276
7.8 Web Buckling	277
7.9 Web Crippling	278
7.10 Diagonal Buckling	280
7.11 Design of Laterally Supported Beams	281
7.12 Design of Laterally Unsupported Beams	281
7.13 Built-up Beams (Plated Beams)	283
7.14 Lintels	288
7.15 Purlins	289
7.16 Encased Beam	293
7.17 Beam Bearing Plates	294
7.18 Castellated Beam	295
7.19 Effect of Holes in Beam	297
7.20 Composite Beam and Shear Connectors	297
<i>Solved Examples</i>	301
<i>Exercises</i>	326
8. Gantry Girders	330
8.1 Introduction	330
8.2 Loads	332
8.3 Specifications	334
8.4 Design	334
<i>Solved Examples</i>	337
<i>Exercises</i>	348
9. Plate Girder	350
9.1 Introduction	350
9.2 Types of Sections	351

9.3	Elements of Plate Girder	351
9.4	General Considerations	352
9.5	Proportioning of Web	354
9.6	Proportioning of Flanges	357
9.7	Self-weight of Plate Girder	361
9.8	Curtaiment of Flange Plates	362
9.9	Connections	365
9.10	Stiffeners	369
9.11	Bearing Stiffener	370
9.12	Intermediate Stiffeners	373
9.13	Web Splices	376
9.14	Flange Angle Splice	383
9.15	Flange Plate Splice	385
9.16	Design Steps of a Plate Girder	385
9.17	Comparison of Welded and Riveted Plate Girders	385
	Solved Examples	386
	Exercises	408
10.	Eccentric Connections	412
10.1	Introduction	412
10.2	Beam-column Connections	413
10.3	Riveted Shear Connections	415
10.4	Welded Shear Connections	424
10.5	Moment Resistant Connections	431
10.6	Semi-rigid Connections	443
	Solved Examples	444
	Exercises	478
11.	Industrial Buildings	481
11.1	Introduction	481
11.2	Planning	482
11.3	Structural Framing	482
11.4	Types	483
11.5	Roof and Side Coverings	485
11.6	Elements of an Industrial Building	485
11.7	Purlins	485
11.8	Sag Rods	486
11.9	Principal Rafter	487
11.10	Roof Trusses	487
11.11	Gantry Girders	493
11.12	Brackets	493
11.13	Crane Columns	493
11.14	Girts	497
11.15	Bracing	498
11.16	Design Steps of Industrial Building	500
	Solved Examples	500
	Exercises	547

12. Water Tanks

- 12.1 Introduction 550
- 12.2 Permissible Stresses 550
- 12.3 Thickness Specifications 551
- 12.4 Stiffening Angle 551
- 12.5 Stand-pipe 551
- 12.6 Elevated Tanks 554
- 12.7 Circular Tanks 554
- 12.8 Rectangular Tanks 559
- 12.9 Pressed Steel Tank 562
- 12.10 Wind Force 570
- 12.11 Earthquake Force 571
- 12.12 Staging 572
 - Solved Examples 575
 - Exercises 608

13. Steel Stacks

610

- 13.1 Introduction 610
- 13.2 Proportioning of Stack 611
- 13.3 Constructional Details 611
- 13.4 Codal Provisions 613
- 13.5 Forces on a Stack 615
- 13.6 Load Combinations for Self-supporting Steel Stacks 618
- 13.7 Stresses in Self-supporting Steel Stacks 618
- 13.8 Design Procedure for Self-supporting Steel Stacks 618
- 13.9 Guyed Steel Stacks 622
- 13.10 Pull on Guy Wires 622
- 13.11 Design Procedure for Guyed Steel Stacks 626
 - Solved Examples 629
 - Exercises 643

14. Bridges

644

- 14.1 Introduction 644
- 14.2 Components 645
- 14.3 Types 646
- 14.4 Choice of the Type of Bridge 651
- 14.5 The Floor System 652
- 14.6 End Supports 653
- 14.7 Truss Girder Bridges 655
- 14.8 Bracing of Truss Girder Bridges 656
- 14.9 Plate Girder Bridges 658
- 14.10 Bracing of Plate Girder Bridges 658
- 14.11 Loads 659
- 14.12 Dead Load 659
- 14.13 Live Load 660
- 14.14 Impact Load 679
- 14.15 Wind Force 680

14.16	Seismic Forces	682	
14.17	<u>Longitudinal Forces</u>	<u>683</u>	
14.18	<u>Racking Forces</u>	<u>683</u>	
14.19	<u>Centrifugal Force</u>	<u>683</u>	
14.20	Temperature Effects	684	
14.21	Secondary Stresses	684	
14.22	Design Procedure of Bridges	684	
	<i>Solved Examples</i>	685	
	<i>Exercises</i>	704	
15.	Tubular Structures		706
15.1	<u>Introduction</u>	<u>706</u>	
15.2	<u>Classification</u>	<u>706</u>	
15.3	<u>Advantages and Disadvantages</u>	<u>707</u>	
15.4	<u>Behaviour of Tubular Sections</u>	<u>707</u>	
15.5	<u>Minimum Thickness</u>	<u>709</u>	
15.6	<u>Combined Stresses</u>	<u>710</u>	
15.7	<u>Connections</u>	<u>710</u>	
	<i>Solved Examples</i>	713	
	<i>Exercises</i>	715	
16.	Light-Gauge Steel Construction		716
16.1	<u>Introduction</u>	<u>716</u>	
16.2	<u>Shapes</u>	<u>716</u>	
16.3	Definitions	718	
16.4	Properties of Sections	720	
16.5	Local Buckling of Plate Elements	720	
16.6	Effective Design Width	724	
16.7	Specifications	729	
16.8	Basic Allowable Design Stresses	731	
16.9	Allowable Compressive Stresses in Unstiffened Elements	731	
16.10	Compression Members	733	
16.11	Flexural Members	737	
	<i>Solved Examples</i>	741	
	<i>Exercises</i>	749	
17.	Elementary Plastic Analysis and Design		752
17.1	Introduction	752	
17.2	Idealized Stress-strain Curve for Mild Steel	752	
17.3	Ultimate Load-carrying Capacity of Tension Members	753	
17.4	Ultimate Load-carrying Capacity of Compression Members	754	
17.5	Flexural Members	755	
17.6	<u>Shape Factor</u>	<u>761</u>	
17.7	<u>Load Factor</u>	<u>762</u>	
17.8	<u>Mechanism</u>	<u>762</u>	
17.9	<u>Plastic Collapse</u>	<u>764</u>	
17.10	<u>Conditions in Plastic Analysis</u>	<u>764</u>	

17.11	Principle of Virtual Work	765
17.12	Theorems of Plastic Analysis	765
17.13	Methods of Analysis	766
17.14	Cancellation of Hinge in the Combined Mechanism (Beam + Sway)	767
17.15	Design	768
17.16	Scope of Plastic Analysis	768
17.17	Limitations of Plastic Analysis	769
17.18	Plastic Design vs. Elastic Design	770
	Solved Examples	774
	Exercises	804
18.	Introduction to Limit State Design	808
18.1	Introduction	808
18.2	Basis for Design	808
18.3	Limit States	809
18.4	Actions (Loads)	810
18.5	Design Criteria	811
18.6	Limit States of Strength	813
18.7	Limit States of Serviceability	815
18.8	Method of Determining Action Effects	818
	Summary	819
Appendices		820
I	Abbreviations	820
II	Unit Weight of Building Materials	820
III	Live Loads	821
IV	Wind Map of India	823
V	Response Spectra for Rocks and Soil Sites for 5% Damping (IS: 1893–2002)	823
VI	Permissible Bearing Pressures on Subsoils	824
VII	Stress Area of Bolts	824
VIII	Shear Centre	824
IX	External Pressure Coefficients (C_{pe}) for Roofs of Rectangular Clad Buildings	825
X	External Pressure Coefficients (C_{pe}) for Walls of Rectangular Buildings	826
XI	Average Acceleration Spectra (IS: 1893–1984)	827
XII	Sizes and Properties of Steel Tubes for Structural Purposes	828
XIII	Shape Factor F	831
XIV	Load Factor F	831
List of Symbols		832
Index		835



Tata McGraw-Hill

Adapted in India by arrangement with The McGraw-Hill Companies, Inc., New York

Sales Territories: India, Pakistan, Nepal, Bangladesh, Sri Lanka and Bhutan

Fluid Mechanics: Fundamentals and Applications (SI Units), 2/e

First reprint 2010

RAZYCRBZDLAAB

Copyright © 2010, 2006, by The McGraw-Hill Companies, Inc. All rights reserved. No part of this publication may be reproduced or distributed in any form or by any means, electronic, mechanical, photocopying, recording, or otherwise or stored in a database or retrieval system without the prior written permission of The McGraw-Hill Companies, Inc. including, but not limited to, in any network or other electronic storage or transmission, or broadcast for distance learning.

This edition can be exported from India only by the publishers,
Tata McGraw Hill Education Private Limited.

ISBN (13): 978-0-07-070034-5

ISBN (10): 0-07-070034-6

Managing Director: *Ajay Shukla*

Head—Higher Education Publishing and Marketing: *Vibha Mahajan*

Manager—Sponsoring SEM & Tech Ed: *Shalini Jha*

Assoc. Sponsoring Editor: *Suman Sen*

Development Editor: *Devshree Lohchab*

Executive—Editorial Services: *Sohini Mukherjee*

Jr Manager—Production: *Somomita Taneja*

Dy Marketing Manager—SEM & Tech Ed: *Biju Ganesan*

General Manager—Production: *Rajender P Ghansela*

Asst General Manager—Production: *B L Dogra*

Information contained in this work has been obtained by Tata McGraw-Hill, from sources believed to be reliable. However, neither Tata McGraw-Hill nor its authors guarantee the accuracy or completeness of any information published herein, and neither Tata McGraw-Hill nor its authors shall be responsible for any errors, omissions, or damages arising out of use of this information. This work is published with the understanding that Tata McGraw-Hill and its authors are supplying information but are not attempting to render engineering or other professional services. If such services are required, the assistance of an appropriate professional should be sought.

Typeset at Text-o-Graphics, B1/56 Arawali Apartment, Sector 34, Noida 201 301 and printed at Pushp Print Services, B-39/12A, Gali No. 1, Arjun Mohalla, Moujpur, Delhi 110 053

Cover printed at: Rashtriya Printers

The McGraw-Hill Companies

Copyrighted material

General Considerations

1.1 INTRODUCTION

The design of steel structures involves the planning of the structure for specific purposes, proportioning of members to carry loads in the most economical manner, and considerations for erection at site. First, the structure should serve the purpose for which it is intended and this is achieved by proper functional planning. Secondly, it should have adequate strength to withstand direct and induced forces to which it may be subjected during its life span. An inadequate assessment of forces and their effects on the structure may lead to excessive deformation and its failure. Therefore, the design of structures includes functional planning, acknowledgement of the various forces, strength of materials and the design methods. In addition the structure should be economical and easy to erect. An economical structure requires an efficient use of steel and skilled and unskilled labour. Although this objective can usually be accomplished by a design that requires a minimum amount of steel, savings can often be realized by using more steel if it results in a simpler structural form with less fabrication. In fact, as of today, materials account for one-third or less of the cost of a typical steel structure, whereas labour costs can account for 60 per cent or more.

Steel structures are composed of elements which are rolled to a basic cross-section in a mill, and worked to the desired size and form in a fabricating shop or site. A significant difference between steel and concrete constructions is that the designer has more control over the shape of reinforced cement concrete elements. For building a steel structure, the designer is normally compelled to use standard rolled sections. Fortunately, the variety of steel sections available is so great that any desired structural effect can be achieved in steel.

Steel, as a building material has been used extensively in various types of structures. Some of the examples of civil engineering works in steel are high-rise building skeletons, industrial buildings, transmission towers, railway bridges, overhead tanks, chimneys (stacks), towers, bunkers and silos. We shall now discuss the various aspects of design.

Functional Planning

This takes into consideration the overall planning of the structure in accordance to the purpose it is meant for. It also includes the layout and proper arrangement of space. Functional planning involves a lot of imagination and is done with the help of architects.

Design of Structural Elements

The position of elements, viz. beams, columns, trusses, purlins, etc. are marked on the plan provided by architects. Various combinations of possible loads are ascertained and the members are proportioned on the basis of selected design method. A suitable section for the member thus proportioned is selected from I.S. Hand Book No. 1. The section is then checked for the prescribed limits specified in the code of practice. The section designed should use steel with a minimum strength not exceeding 5 per cent than that required. The structure designed should perform satisfactorily for the intended period with permitted deformations, vibrations and comfort to the user.

A designer should take care of the following important points:

1. A section selected should be available in the local market. Unusual sizes and rare rolled sections cost more and should be avoided.
2. In steel structure buildings, the various elements should be compatible at the joints. If a large number of different shapes and sizes of elements are designed, it will be practically difficult to fit the members, and connections will be a problem. For example, in a continuous beam of a framed building the designer may provide different sections in various spans for economy. But this arrangement will generate connection problems and look unattractive.
3. The steel structures in exposed conditions require frequent maintenance. Therefore, the elements of such structures, e.g. bridges, water tanks, etc. should have access to the exposed elements.
4. Transportation facilities for built-up sections should be explored before designing them.

Erection

Steel structure elements should be erected with proper care to avoid secondary stresses. The section should be of a size which can be easily erected.

Standard Specifications and Codes

To facilitate safe and economical design, standard specifications and codes are prepared on the basis of past design practice, experience based on behaviour of existing structures, knowledge gained from failures, and from research data. The information thus gathered is critically examined, assessed and approved by a body of experts and is published in the form of codes and standards. For this purpose the Bureau of Indian Standards has published a number of codes, standards and hand books, some of which will be referred to frequently and are listed below.

1. I.S. Hand Book No. 1: Properties of Structural Steel Rolled Sections
2. I.S. 875-1987: Code of Practice for Design Loads for Building and Structures
3. I.S. 800-1984: Code of Practice for use of Structural Steel in General Building Construction.

A building code has the force of law and is administered by a government entity. Building codes do not give design procedures, but they do specify the design requirements and constraints that must be satisfied. In contrast to building codes, design specifications give more specific guidance for the design of structural members and their connections. They present the guidelines and criteria that enable a structural engineer to achieve the objectives mandated by a building code. Design

specifications represent what is considered to be good engineering practice based on the latest research. They are periodically revised and updated by the issuance of supplements or completely new editions. As with building codes, design specifications are written in a legal format by non-profit organisations. They have no legal standing on their own, but by presenting design criteria and limits in the form of legal mandates and prohibitions, they can easily be adopted, by reference, as part of a building code.

1.2 ADVANTAGES OF STEEL AS A STRUCTURAL MATERIAL

Steel has many advantages as a structural material.

1. Steel members have high strength per unit weight. Therefore, a steel member of a small section which has little self weight is able to resist heavy loads.
2. Being light, steel members can be conveniently handled and transported. For this reason, prefabricated members can be frequently provided.
3. Properly maintained steel structures have a long life.
4. The properties of steel mostly do not change with time. This makes steel the most suitable material for a structure.
5. Steel, being a ductile material, does not fail suddenly, but gives visible evidence of impending failure by large deflections.
6. Additions and alterations can be made easily to steel structures.
7. They can be erected at a faster rate.
8. Steel has the highest scrap value amongst all building materials.

1.3 DISADVANTAGES OF STEEL AS A STRUCTURAL MATERIAL

1. Steel structures, when placed in exposed conditions, are subjected to corrosion. Therefore, they require frequent painting.
2. Steel structures need fire proof treatment, which increases cost.

1.4 STRUCTURAL STEEL

Structural steel has been classified by the Bureau of Indian Standards based on its ultimate or yield strength. For example, Fe-410 steel has a minimum tensile strength of 410 N/mm^2 . The mechanical properties of steel largely depend on its chemical composition, rolling methods, rolling thickness, heat treatment and stress history. Some of the important mechanical properties of structural steel are given in Table 1.1.

Table 1.1 Mechanical Properties of Structural Steels

S. No.	Property	Value
1.	Yield stress (f_y)	220–540 N/mm^2
2.	Ultimate tensile strength	$1.2 f_y$
3.	% Elongation (low carbon steel)	20
4.	Modulus of Elasticity (E)	$2 \times 10^5 \text{ N/mm}^2$
5.	Shear modulus (G)	$0.4 E$
6.	Poisson's ratio (μ)	
	(i) elastic range	0.3
	(ii) plastic range	0.5

The chemical composition of some of the steels is given in Table 1.2. Primary elements such as carbon, sulphur, phosphorus, manganese and silicon influence the mechanical properties of steel. Of these, carbon has the maximum influence on the mechanical properties of steel. Iron-carbon alloys containing up to 2 per cent carbon are called *carbon steel* while those having more than 2% are called *cast steel*. With increase in carbon the tensile strength of steel increases but the ductility falls. However, by alloying chromium, nickel, molybdenum, vanadium, etc. the tensile strength can be increased while retaining the desired ductility.

Table 1.2 Chemical Composition of Structural Steels

S. No.	Quality of Steel	Designation	I.S. Code	Maximum Percentage					Tensile Strength (N/mm ²)
				C	S	P	Mn	Si	
1.	Standard structural C = 0.2–0.35%	Fe-410S	226	0.23	0.055	0.055	—	0.10	410
2.	Structural ordinary	Fe 310	1977	0.23	0.07	0.07	—	—	310
		Fe 410-O	1977	0.23	0.07	0.07	—	—	410
3.	Weldable	Fe 410-H	2062	0.20	0.055	0.055	1.0	—	410
		Fe 440 HT	8500	0.25	0.055	0.055	1.5	—	440
		Fe 490 HT	8500	0.25	0.04	0.04	1.5	—	490
		Fe 590 HT	8500	0.25	0.05	0.05	1.5	—	590

Fe = steel, C = carbon, S = sulphur, P = phosphorus, Mn = manganese, Si = silicon

1.5 STRESS-STRAIN CURVE FOR MILD STEEL

The stress-strain curve for mild steel presents a lot of information necessary to understand how it will behave in a given situation. Therefore, for a steel design method to be satisfactory it is essential to be conversant with the stress-strain relationship of mild steel.

Curve *OABCDEF* in Fig. 1.1 represents the stress-strain curve when a mild steel specimen is subjected to a gradually increasing tensile load. Various elements of the curve are as follows.

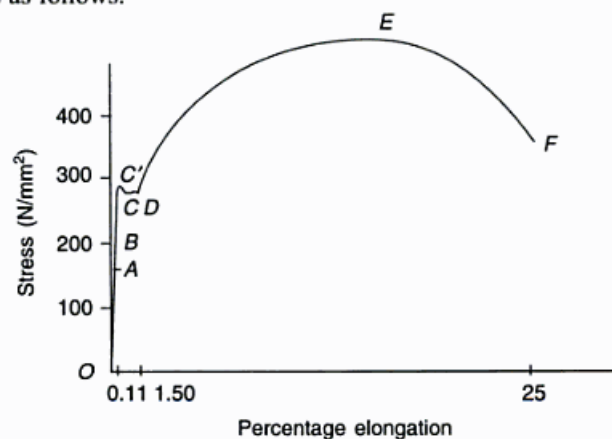

Fig. 1.1 Stress-strain Curve of Mild Steel

OAB— represents a straight line curve—the strain produced is proportional to the stress producing it, i.e. it obeys Hook's law.

A— represents the limit of proportionality—the stress beyond which linear variation ceases.

B— represents the elastic limit—the maximum stress up to which a specimen regains its original length on removal of the applied load. This stress, in general, is not measured and *B* is assumed to coincide with *A*.

C'C— represents the upper, lower yield point—the stress at which there is a definite increase in strain without any further increase in stress. The magnitude of stress corresponding to the upper yield point *C'* depends on the cross-sectional shape of the specimen and the type of equipment used to perform the test. In many of the structural steel hot rolled sections, the upper yield point is not obtained due to residual stresses from the hot rolling process. Hence it has no practical significance. The stress corresponding to the lower yield point *C* is the yield stress f_y with a typical magnitude of 250 N/mm^2 for mild steel. The lower yield point is observed if the rate of loading is slow whereas the upper yield point is observed if load is applied rapidly. For the region *OC'*, the material is elastic, and the slope *E*, is the *Young's modulus*. On average *E* is $2 \times 10^5 \text{ N/mm}^2$. The strain at the yield stress is about 0.0012.

CD— represents plastic yielding—it is the strain which occurs after the yield point, with no increase in stress. The point *D* of plastic yield range is somewhat variable but a typical strain is 0.014. The strain in the range *CD* is thus at least ten times the strain at the yield point.

DE— represents strain hardening—it is a range where additional stress produces additional strain. Strain increases fast with stress till ultimate load is reached. As of today this portion of the diagram is not being used for structural design.

E— represents the ultimate stress—the stress corresponding to the ultimate load. The initial slope of this region is about 4 per cent of Young's modulus. At a strain of at least 0.2, the stress reaches its maximum value *E*.

EF— stress falls with rapid increase in strain till the specimen breaks.

F— represents breaking stress—the stress corresponding to the breaking load.

Notes

1. The strain that occurs before the yield point is called *elastic strain*, and that which occurs after the yield point with no increase in stress is called *plastic strain*. The latter strains usually vary from 10 to 15 times the elastic strains.
2. The ideal stress-strain curve for mild steel in compression is identical to the one in tension up to the point of maximum stress. However, the actual behaviour is different and indicates an apparently reduced yield stress in compression. The divergence from the ideal path is called the *Bauchinger effect*.

1.6 ROLLED STEEL SECTIONS

In the design process outlined earlier, one of the objectives—and the primary emphasis of this book—is the selection of the appropriate cross-sections for the individual members of the structure being designed. Most often, this selection will

entail choosing a standard cross-sectional shape that is widely available rather than requiring the fabrication of a shape with unique dimensions and properties. The largest category of standard shapes includes those produced by *hot-rolling*. In the manufacturing process, which takes place in a rolling mill, molten steel is taken from the furnace and poured into a *continuous casting* system where the steel solidifies but is never allowed to cool completely. The hot steel passes through a series of rollers that squeeze the material into the desired cross-sectional shape. Rolling the steel while it is still hot allows it to be deformed with no resulting loss in ductility, as would be the case with cold-working. During the rolling process, the member increases in the length and is cut to standard lengths, which are subsequently cut (in fabricating shop) to the length required for particular structure.

Structural steel can be rolled into various shapes and sizes. Usually sections having larger moduli of section in proportion to their cross-sectional areas are preferred. Steel sections are usually designated by their cross-sectional shapes. The shapes of the rolled steel sections available today have been developed to meet structural needs. Cross-section and size are governed by a number of factors: arrangement of material for optimum structural efficiency; functional requirements (surfaces that are easy to connect to, flat surfaces suitable for supporting other materials, etc.); dimensional and weight capacity of rolling mills; and material properties which, for example, inhibit the hot rolling of wide thin elements because of excessive warping or cracking that might occur.

I.S. Hand Book No. 1 published by the Bureau of Indian Standards provides the dimensions, weights and geometrical properties of various sections. The weight of sections in the Hand Book are given in kg/m length. However, for convenience, to use this data in SI units, the weights have been converted in N/m length by multiplying the weights with a factor of 9.81 throughout the text, solved examples and exercises. Structural shapes are abbreviated by a certain system described in the Hand Book for use in drawings, specifications and designs.

Cross-sections of some of the more commonly used hot rolled shapes are shown in Fig. 1.2 and are described as follows.

- | | |
|----------------------------------|-------------|
| 1. Rolled steel I-Sections | Fig. 1.2(a) |
| 2. Rolled steel channel sections | Fig. 1.2(b) |
| 3. Rolled steel T-Sections | Fig. 1.2(c) |
| 4. Rolled steel angle-sections | Fig. 1.2(d) |
| 5. Rolled steel tube-sections | Fig. 1.2(e) |
| 6. Rolled steel bars | Fig. 1.2(f) |
| 7. Rolled steel flats | Fig. 1.2(g) |
| 8. Rolled steel plates | |
| 9. Rolled steel sheets | |
| 10. Rolled steel strips | |

Angle sections were probably the first shapes rolled and produced in 1819 in America. I-beam shape was introduced by Zores of France in 1849. By 1870 Channels and Tees were developed. All these early shapes were made of wrought iron. The first true skeletal frame structure, the Home Insurance Company Building, was built in Chicago in 1884.

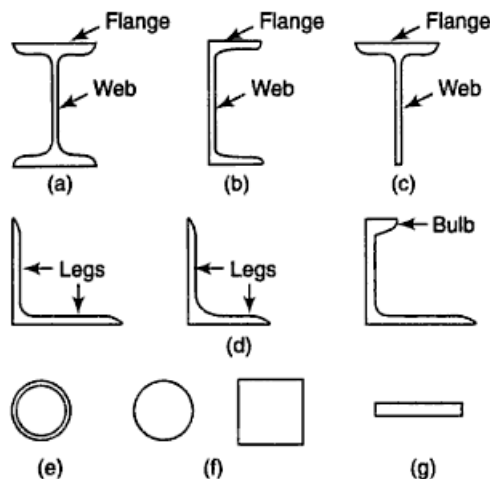

Fig. 1.2 Rolled Structural Shapes

The designations of various types of rolled steel sections are listed in Appendix I.

An I-Section is designated by its depth and weight, e.g., I.S.L.B. 500 @ 735.8 N/m means, the I-Section is 500 mm deep and the self weight is 735.8 N per metre length.

A channel section is designated by its depth and weight. For instance, I.S.L.C. 350 @ 380.6 N/m means that the channel section is 350 mm deep and the self weight is 380.6 N per metre length.

Note All standard I-beams and channels have a slope on the inside face of the flange of $16\frac{2}{3}\%$.

A T-Section is designated by its depth and weight, e.g., I.S.N.T. 150 @ 223.7 N/m, means the Tee-Section is 150 mm deep and the self weight is 223.7 N per metre length.

An angle-section is designated by its leg lengths and thickness. For example, I.S.A. 40 × 25 × 6 mm means, the section is an unequal angle with legs 40 mm and 25 mm in length and thickness of the legs 6 mm.

Note Bulb angles need a special mention as are generally used in shipbuilding and are uncommon in structures. However these have been common in small depth gantry girders, where the bulb helps to stiffen the outstanding leg, especially when the angle, is under compression along its length. A small depth horizontal girder, whose flanges are the bulbs counteracts the bending action which sometimes occurs when the crane, instead of using a direct lift and cross travel, drags the load across the shop floor in a direction normal to the girder length.

Steel tubes are designated by their outside diameter and self weight.

Rolled steel bars may be circular or square and are designated by diameter or side respectively, e.g., I.S.SQ. 10 mm means a square bar of 10 mm side and I.S.RO. 10 mm means a round bar of 10 mm diameter.

Steel flats are designated by width and thickness of the section, e.g., 30 I.S.F. 10 mm means the flat is 30 mm wide and 10 mm thick.

Steel plates are designated by length, width and thickness, e.g., I.S.PL. 2000 mm × 1000 mm × 8 mm, means the plate is 2000 mm long, 1000 mm wide and 8 mm thick.

Steel sheets are designated by length, width and thickness, e.g., I.S.SH. 2000 mm \times 600 mm \times 4 mm, means the sheet is 2000 mm long, 600 mm wide and 4 mm thick.

Steel strips are designated by width and thickness, e.g., I.S.ST. 200 mm \times 2 mm, means the strip is 200 mm wide and 2 mm thick.

In most cases, one of the standard shape described above will satisfy design requirements. If the requirements are especially server, then a built-up section (Fig. 1.3) may be needed. Such a situation arises when none of the standard rolled shapes are large enough; that is, the cross-section does not have enough area or moment of inertia.

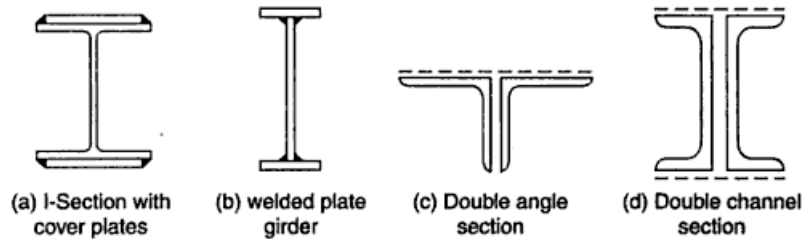

Fig. 1.3 Built-up Sections

Sometimes a standard shape is augmented by additional cross-sectional elements, as when cover plate(s) is (are) connected to one/both flange(s) of the section (Fig. 1.3(a, b)). Built-up shapes can also be created by attaching two or more standard rolled shapes to each other. Most widely used combinations are double angles or double channels placed back to back and connected at intervals along their length (Fig. 1.3(c, d)). There are many other possibilities, some of which are illustrated throughout this book.

Choice of Section

The design of steel sections is governed by cross-sectional area and section modulus. It has been seen that a variety of steel sections are rolled, but due to the limitations of rolling mills only a few are available. Also, if a section is in demand, it is rolled regularly but one which is in little demand is rolled only on order and hence costs more. Therefore, the design is not only governed by sectional properties but also on availability of the section in the market, which becomes a major consideration. Another factor governing the choice is the ease with which sections can be connected.

1.7 LOADS

For the safe design of a structure it is essential to have a knowledge of various types of loads and their worst combinations to which it may be subjected during its life span.

Types of Loads

The following are the various types of loads.

1. Dead load
6. Earth pressure

- | | |
|-----------------|-------------------------------------|
| 2. Live loads | 7. Water current load |
| 3. Wind load | 8. Impact load |
| 4. Seismic load | 9. Temperature and erection effects |
| 5. Snow load | |

1.8 DEAD LOAD

The dead load of a structure is not known before it is designed. It is assumed or estimated on the basis of experience. After designing, the assumed dead load is compared with the actual dead load. If the difference is significant, the assumed dead load is revised and the structure is redesigned. Appendix II gives the dead loads of some structural materials. Dead load calculations should also include the superimposed loads that are permanently attached to the structure, e.g. partition walls, parapets, etc.

1.9 LIVE LOADS

Live loads are those which may change in position and magnitude. The live loads on roofs are specified in I.S: 875-1987 and are listed in Appendix III. The live loads on floors as specified in Appendix III, may be reduced in the design of columns, piers, walls, and foundations, as given in Table 1.3.

Table 1.3 Percentage Reduction of Total Live Load

<i>Number of Floors Carried by Member Under Consideration</i>	<i>% Reduction of Total Live Load on all Floors Above the Member Under Consideration</i>
1	0
2	10
3	20
4	30
5 to 10	40
Over 10	50

Note The above reduction is not made for storage buildings and factories designed for live loads less than 5000 N/m². If the live load is more than 5000 N/m² the reduction may be applied provided that the loading assumed for any column, pier, etc. is not less than what it would have been if all the floors had been designed for 5000 N/m² with no reduction.

When a single span of beam or girder supports not less than 50 m² of floor area at one general level, the live load may be reduced in the design of beam or girder by 5 per cent for each 50 sq. metres supported, subject to maximum reduction of 25 per cent. This is not applicable to storage buildings.

1.10 WIND FORCES

All exposed structures, irrespective of their heights, are affected by wind forces. As wind blows against a structure, its surface (the outer shell) experiences the effect of wind force. The wind pressure intensity at any height of a structure depends upon the velocity and density of air, shape and height of the structure, topography of the surrounding ground surface and the angle of wind attack.

Design Wind Speed

For the calculation of wind load on structures I.S. 875-1987 relates the intensity of wind pressure to the basic maximum wind speed (V_b), over a short interval of 3 seconds, with a 50 years return period, for different zones of the country. The basic wind speed for any site may be obtained from Appendix IV and is modified to include risk level, terrain roughness, height and size of structure, and local topography, to get the design wind velocity (V_z) at any height for the structure.

$$V_z = V_b k_1 k_2 k_3 \tag{1.1}$$

- where V_z = design wind speed at any height z in m/s
 k_1 = probability factor or risk coefficient
 k_2 = terrain, height and structure size factor
 k_3 = topography factor

Note The design wind speed up to a 10 m height from mean ground level is considered constant.

Risk Coefficient Since the suggested life of buildings and structures is 50 years, a basic wind speed having a mean return period of 50 years is considered. The values of k_1 for the probable periods are given in Table 1.4.

Table 1.4 Risk Coefficients for Different Classes of Structures in Different Wind Speed Zones

Class of Structures	Mean Probable Design Life of Structure in Years	k_1 Factor for Basic Wind Speed (m/s) of					
		33	39	44	47	50	55
All general buildings and structures	50	1.0	1.0	1.0	1.0	1.0	1.0
Temporary sheds, structures such as those used during construction operations (for example, form-work and false-work), structures during construction stages and boundary walls	5	0.82	0.76	0.73	0.71	0.70	0.67
Buildings and structures presenting a low degree of hazard to life and property in the event of failure, such as isolated towers in wooded areas, farm buildings other than residential buildings	25	0.94	0.92	0.91	0.90	0.90	0.89
Important buildings and structures such as hospitals, communication buildings/towers, power plant structures	100	1.05	1.06	1.07	1.07	1.08	1.08

For exceptionally important structures as nuclear power reactors, satellite communication towers etc., Eq. (1.2) may be used to estimate k_1 for different periods of exposure and chosen probability of exceedance (risk level). The probability level of 0.63 is normally considered sufficient for the design of structures against wind effects.

$$k_1 = \frac{X_{N,P}}{X_{50,0.63}} = \frac{A - B \left[\log \left\{ -\frac{1}{N} \log (1 - P_N) \right\} \right]}{A + 4B} \quad (1.2)$$

- where N = mean probable design life of structure in years
- P_N = risk level in N consecutive years (0.63)
- $X_{N,P}$ = extreme wind speed for given values of N and P_N
- $X_{50,0.63}$ = extreme wind speed for $N = 50$ years, $P_N = 0.63$
- A, B = coefficients as given in Table 1.5

Table 1.5 Values of Coefficients A and B

Zone	A	B
33 m/s	83.2	9.2
39 m/s	84.0	14.0
44 m/s	88.0	18.0
47 m/s	88.0	20.5
50 m/s	88.8	22.8
55 m/s	90.8	27.3

k_2 Factor This depends upon terrain, height and structure size. Terrain has been grouped under four categories (Table 1.6) depending upon the effect of obstructions constituting the ground surface roughness.

Table 1.6 Terrain Category

Category	Height of Object	Structures Near
1.	< 1.5 m	Open sea coasts, flat treeless plains
2.	1.5–10 m (with well scattered obstructions)	Parks, air fields, undeveloped sparsely outskirts of towns and suburbs, open land adjacent to sea coast
3.	Upto 10 m (with closely spaced obstructions)	Wooded areas, towns, industrial areas
4.	> 25 m (with high closely spaced obstructions)	Large city centres, well developed industrial complexes

On the basis of size, structures are grouped as (1) Class A—having maximum dimension less than 20 m (2) Class B—having maximum dimension 20–50 m and (3) Class C—having maximum dimension greater than 50 m. The design wind speed at different heights of the structure can be obtained by multiplying the coefficient k_2 , given in Table 1.7, with the basic wind speed.

Table 1.7 k_2 Factors to Obtain Design Wind Speed Variation with Height in Different Terrains for Different Classes of Buildings/ Structures

Height (m)	Terrain Category 1			Terrain Category 2			Terrain Category 3			Terrain Category 4		
	A	B	C	A	B	C	A	B	C	A	B	C
10	1.05	1.03	0.99	1.00	0.98	0.93	0.91	0.88	0.82	0.80	0.76	0.67
15	1.09	1.07	1.03	1.05	1.02	0.97	0.97	0.94	0.87	0.80	0.76	0.67
20	1.12	1.10	1.06	1.07	1.05	1.00	1.01	0.98	0.91	0.80	0.76	0.67
30	1.15	1.13	1.09	1.12	1.10	1.04	1.06	1.03	0.96	0.97	0.93	0.83
50	1.20	1.18	1.14	1.17	1.15	1.10	1.12	1.09	1.02	1.10	1.05	0.95
100	1.26	1.24	1.20	1.24	1.22	1.17	1.20	1.17	1.10	1.20	1.15	1.05
150	1.30	1.28	1.24	1.28	1.25	1.21	1.24	1.21	1.15	1.24	1.20	1.10
200	1.32	1.30	1.26	1.30	1.28	1.24	1.27	1.24	1.18	1.27	1.22	1.13
250	1.34	1.32	1.28	1.32	1.31	1.26	1.29	1.26	1.20	1.28	1.24	1.16
300	1.35	1.34	1.30	1.34	1.32	1.28	1.31	1.28	1.22	1.30	1.26	1.17
350	1.37	1.35	1.31	1.36	1.34	1.29	1.32	1.30	1.24	1.31	1.27	1.19
400	1.38	1.36	1.32	1.37	1.35	1.30	1.34	1.31	1.25	1.32	1.28	1.20
450	1.39	1.37	1.33	1.38	1.36	1.31	1.35	1.32	1.26	1.33	1.29	1.21
500	1.40	1.38	1.34	1.39	1.37	1.32	1.36	1.33	1.28	1.34	1.30	1.22

k_3 Factor The basic wind speed (V_b) accounts for general site level above mean sea level. However, local features such as hills, valleys, cliffs, escrapments or ridges affect it. The influence of the topographic feature is considered to extend $1.5 L_e$ upwind and $2.5 L_e$ downwind of the summit (Fig. 1.4) of crest of the feature, where L_e is the effective horizontal length of the hill depending on upwind slope (θ). The effect is incorporated by a factor k_3 .

The value of k_3 for level ground, where the upwind slope is less than 3° , is unity and that for slopes greater than 3° is confined in the range of 1.0 to 1.36.

For a hill or ridge, $k_3 = 1 + Cs$

where $C = 1.2 \left(\frac{z}{L} \right)$ for upwind slope $3^\circ - 17^\circ$



= 0.36 for upwind slope $> 17^\circ$

z = height of crest of hill

L = projected length of upwind zone from average ground level of crest in wind direction

s = a factor obtained from Fig. 1.5 appropriate to the height H above mean ground level and the distance X from the summit or crest relative to the effective length L_e .

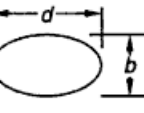
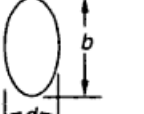
Table 1.8 Force Coefficients C_f for Clad Buildings of Uniform Section (Acting in the Direction of Wind)

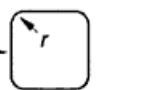
Plan Shape	$V_d b$ m ² /s	C_f for Height/Breadth Ratio						
		Up to 1/2	1	2	5	10	20	∞
 All surfaces rough or with projections Smooth	< 6	0.7	0.7	0.7	0.8	0.9	1.0	1.2
	≥ 6	0.5	0.5	0.5	0.5	0.5	0.6	0.6
 Ellipse $b/d = 1/2$	< 10	0.5	0.5	0.5	0.5	0.6	0.6	0.7
	≥ 10	0.2	0.2	0.2	0.2	0.2	0.2	0.2
 Ellipse $b/d = 2$	< 8	0.8	0.8	0.9	1.0	1.1	1.3	1.7
	≥ 8	0.8	0.8	0.9	1.0	1.1	1.3	1.5
 $b/d = 1$ $r/b = 1/3$	< 4	0.6	0.6	0.6	0.7	0.8	0.8	1.0
	≥ 4	0.4	0.4	0.4	0.4	0.5	0.5	0.5
 $b/d = 1$ $r/b = 1/6$	< 10	0.7	0.8	0.8	0.9	1.0	1.0	1.3
	≥ 10	0.5	0.5	0.5	0.5	0.6	0.6	0.6

(Contd.)

Table 1.8 (Contd.)

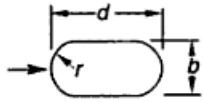
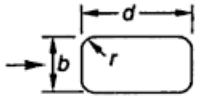
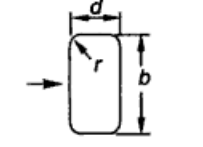
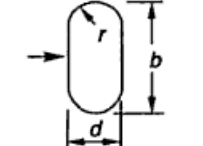
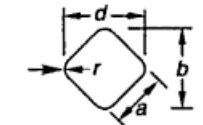
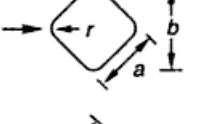
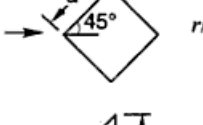
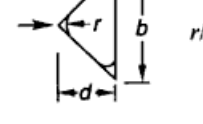
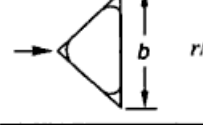
Plan Shape	$V_d b$ m^2/s	C_f for Height/Breadth Ratio						
		Up to 1/2	1	2	5	10	20	∞
 $b/d = 1/2$ $r/b = 1/2$	< 3 ≥ 3	0.3 0.2	0.3 0.2	0.3 0.2	0.3 0.2	0.3 0.3	0.3 0.3	0.4 0.3
 $b/d = 1/2$ $r/b = 1/6$	All values	0.5	0.5	0.5	0.5	0.6	0.6	0.7
 $b/d = 2$ $r/b = 1/12$	All values	0.9	0.9	1.0	1.1	1.2	1.5	1.9
 $b/d = 2$ $r/b = 1/4$	< 6 ≥ 6	0.7 0.5	0.8 0.5	0.8 0.5	0.9 0.5	1.0 0.5	1.2 0.6	1.6 0.6
 $r/a = 1/3$	< 10 ≥ 10	0.8 0.5	0.8 0.5	0.9 0.5	1.0 0.5	1.1 0.5	1.3 0.6	1.5 0.6
 $r/a = 1/12$	All values	0.9	0.9	0.9	1.1	1.2	1.3	1.6
 $r/a = 1/48$	All values	0.9	0.9	0.9	1.1	1.2	1.3	1.6
 $r/b = 1/4$	< 11 ≥ 11	0.7 0.4	0.7 0.4	0.7 0.4	0.8 0.4	0.9 0.5	1.0 0.5	1.2 0.5
 $r/b = 1/12$	All values	0.8	0.8	0.8	1.0	1.1	1.2	1.4

(Contd.)

Table 1.8 (Contd.)

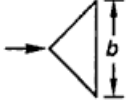
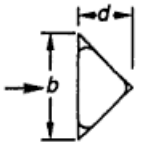
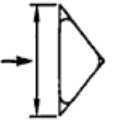
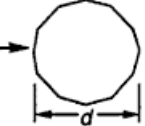
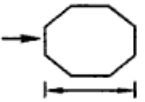
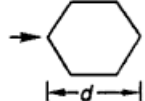
Plan Shape	$V_d b$ m ² /s	C_f for Height/Breadth Ratio						
		Up to 1/2	1	2	5	10	20	∞
 $r/b = 1/48$	All values	0.7	0.7	0.8	0.9	1.0	1.1	1.3
 $r/b = 1/4$	< 8 ≥ 8	0.7 0.4	0.7 0.4	0.8 0.4	0.9 0.4	1.0 0.5	1.1 0.5	1.3 0.5
 $1/48 < r/b < 1/12$	All values	1.2	1.2	1.2	1.4	1.6	1.7	2.1
 12-sided polygon	< 12 ≥ 12	0.7 0.7	0.7 0.7	0.8 0.7	0.9 0.7	1.0 0.8	1.1 0.9	1.3 1.1
 Octagon	All values	1.0	1.0	1.1	1.2	1.2	1.3	1.4
 Hexagon	All values	1.0	1.1	1.2	1.3	1.4	1.4	1.5

Notes In this table $v_d b$ is an indication of the airflow regime.

Design Wind Pressure This pressure at any height above mean ground level is obtained by

$$p_z = 0.6 v_z^2$$

where p_z = design wind pressure in N/m² at height z

Design Wind Force The total wind load for a building as a whole is given by

$$F = C_f A_e p_z \tag{1.3}$$

where C_f = force coefficient of the structure (Table 1.8)

A_e = effective frontal area

p_z = design wind pressure

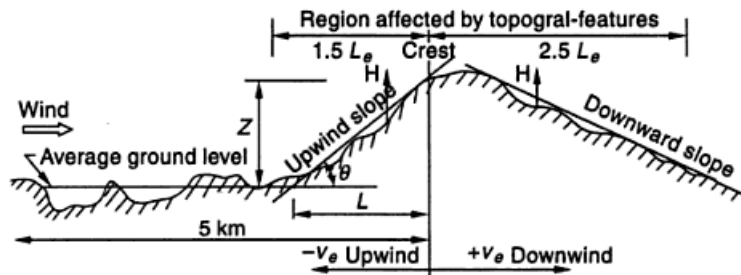

Fig. 1.4 General Notation

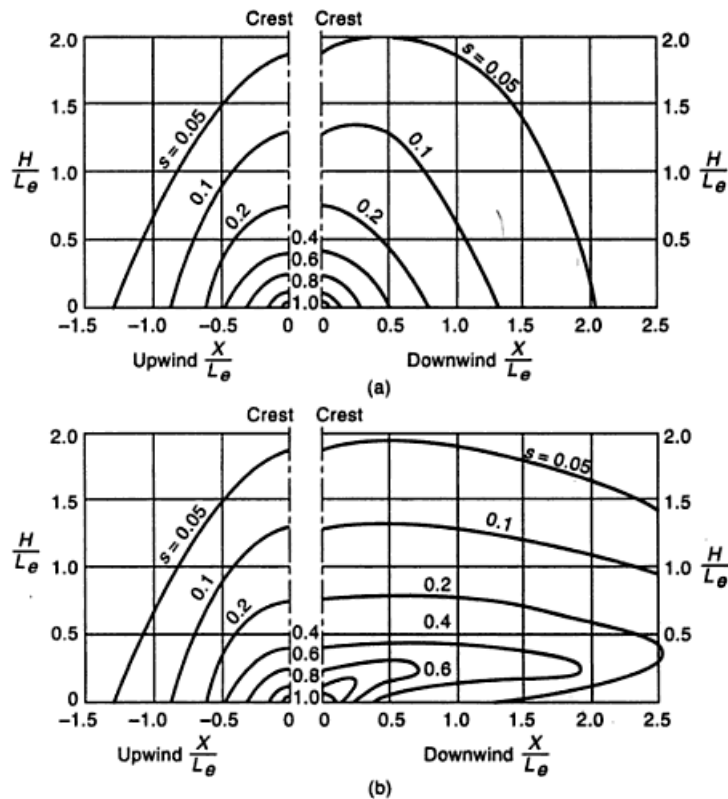

Fig. 1.5 Factor *s* for Hill and Ridge

For flat-sided members such as plates, angles, I-Sections, etc., the force coefficient in two mutually perpendicular directions, normal (C_{fn}) and transverse (C_{ft}) should be considered as given in Table 1.9.

$$\text{Normal force, } F_n = C_{fn} p_z k l b$$

$$\text{Transverse force, } F_t = C_{ft} p_z k l b$$

where k = a coefficient (Table 1.10) depending upon l/b ratio

l = length of the member

b = width of the member across the direction of wind

Table 1.9 Force Coefficients (C_r) for Individual Structural Members of Infinite Length

θ	C_{fn}	C_{ft}	C_{fn}	C_{ft}	C_{fn}	C_{ft}
degrees						
0	+1.9	+0.95	+1.8	+1.8	+1.75	+0.1
45	+1.8	+0.8	+2.1	+1.8	+0.85	+0.85
90	+2.0	+1.7	-1.9	-1.0	+0.1	+1.75
135	-1.8	-0.1	-2.0	+0.3	-0.75	+0.75
180	-2.0	+0.1	-1.4	-1.4	-1.75	-0.1
θ	C_{fn}	C_{ft}	C_{fn}	C_{ft}	C_{fn}	C_{ft}
degrees						
0	+1.6	0	+2.0	0	+2.05	0
45	+1.5	-0.1	+1.2	+0.9	+1.85	+0.6
90	-0.95	+0.7	-1.6	+2.15	0	+0.6
135	-0.5	+1.05	-1.1	+2.4	-1.6	+0.4
180	-1.5	0	-1.7	± 2.1	-1.8	0
θ	C_{fn}	C_{ft}	C_{fn}	C_{ft}	C_{fn}	C_{ft}
degrees						
0	+1.4	0	+2.05	0	+1.6	0
45	+1.2	+1.6	+1.95	+0.6	+1.5	+1.5
90	0	+2.2	+0.5	+0.9	0	+1.9

(Contd.)

Table 1.12 Overall Force Coefficient for Square Towers Composed of Rounded Members

Solidity Ratio of Front Face	Force Coefficient for			
	Subcritical Flow ($DV_d < 6 \text{ m}^2/\text{s}$)		Supercritical Flow ($DV_d \geq 6 \text{ m}^2/\text{s}$)	
	Onto face	Onto corner	Onto face	Onto corner
0.05	2.4	2.5	1.1	1.2
0.1	2.2	2.3	1.2	1.3
0.2	1.9	2.1	1.3	1.6
0.3	1.7	1.9	1.4	1.6
0.4	1.6	1.9	1.4	1.6
0.5	1.4	1.9	1.4	1.6

Table 1.13 Overall Force Coefficient for Equilateral-triangular Towers Composed of Rounded Members

Solidity Ratio of Front Face ϕ	Force coefficient for	
	Subcritical Flow ($DV_d < 6 \text{ m}^2/\text{s}$)	Supercritical Flow ($DV_d \geq 6 \text{ m}^2/\text{s}$)
	All wind directions	All wind directions
0.05	1.8	0.8
0.1	1.7	0.8
0.2	1.6	1.1
0.3	1.5	1.1
0.4	1.5	1.1
0.5	1.4	1.2

1.11 SEISMIC FORCES

When a structure is subjected to ground motions in an earthquake, it responds in a vibratory fashion. The random motion of the ground caused by an earthquake can be resolved in any three mutually perpendicular directions; the two horizontal directions (x and y) and the vertical direction (z). This motion causes the structure to vibrate or shake in all three directions; the predominant direction of shaking is horizontal.

All the structures are primarily designed for gravity loads—force equal to mass times gravity—in the vertical direction. Because of the inherent factor of safety used in the design specifications, most structures tend to be adequate under the vertical shaking. But this should be checked for strength and stability. Generally, however, the inertia forces generated by the horizontal components of ground motion require greater consideration for seismic design. The response of structure to ground motion determines the magnitude of displacements and level of stresses in the elements of the structure. Thus design of a structure requires determination of

seismic forces and selection of member sizes of the structure to keep the displacements and stress levels within prescribed limits.

It is important to draw a distinction between force due to wind and those produced by earthquake. Whereas, wind loads are external loads applied and hence proportional, to the exposed surface of the structure. Earthquake loads are essentially inertia forces; result from the distortions produced by both the earthquake motions and inertial resistance of the structure. Their magnitude is then a function of the mass of the structure rather than its exposed surface. Also, in contrast to structural response to essentially static gravity loads or even to wind loads, which can often be validly treated as static loads—the dynamic character of response to earthquake excitation can seldom be ignored. Thus, whereas in designing for static loads one can feel greater assurance about the safety of structure made up of members of heavy section, in the case of earthquake loading, the stiffer and heavier structure does not necessarily represent the safe design.

Further, the wind loads actually acting on the buildings are usually somewhat smaller than those usually assumed in design. The situation with regard to earthquake forces is entirely different. The seismic forces specified in the code are quite small, relative to the actual forces expected at least once in the life cycle of the building. In contrast to the wind loads the intensity of earthquake loading depends on properties of the structure. For a structure in a particular earthquake zone, both the wind load and seismic load are computed, and the maximum out of the two is considered for design.

Method for Calculating Seismic Forces (IS: 1893–2002)

There are two methods for finding out seismic forces: seismic coefficient method and dynamic analysis. Only seismic coefficient method is discussed here, as dynamic analysis is beyond the scope of the book. The factors taken into account in assessing lateral design forces are described as follows.

Zone Factor (Z) Seismic zoning assesses the maximum severity of shaking that is anticipated in the region. The factor, thus, is used to obtain the design spectrum depending on the perceived seismic hazard in the zone in which the structure is located. Zone factor as per IS: 1893 (Part 1): 2002 are given in Table 1.14.

Table 1.14 Zone Factor (Z)

Seismic Zone	II	III	IV	V
Seismic Intensity	Low	Moderate	Severe	Very Severe
Z	0.10	0.16	0.24	0.36

Importance Factor (I) It is customary to recognise that certain categories of building use should be designed for greater levels of safety and this is achieved by specifying higher lateral design forces. Such categories are the following:

1. Buildings which are essential after an earthquake—hospitals, fire stations, etc.
2. Places of assembly—schools, theatres, etc.
3. Structures whose collapse would endanger the population—nuclear plants, dams, etc.

The importance factors are given in Table 1.15.

Table 1.15 Importance Factor (*I*)

S. No.	Structure	Importance Factor
1.	Important service and community buildings, such as hospitals; schools; monumental structures; emergency buildings like telephone exchanges, television stations, radio stations, railway stations, fire station buildings; large community halls like cinemas, assembly halls and subway stations, power stations	1.5
2.	All other buildings	1.0

Notes

1. The design engineer may choose values of importance factor *I* greater than those mentioned above.
2. Buildings not covered in S. No. (1) may be designed for higher value of *I*, depending on economy, strategy considerations like multi-storey buildings having several residential units.
3. This does not apply to temporary structures like excavations, scaffolding etc. of short duration.

Response Reduction Factor (*R*) For earthquake resistance design a structure is allowed to be damaged in case of severe shaking. Therefore, the structure should be designed for seismic forces much less than what is expected under strong shaking, if the structures were to remain linearly elastic. *Response reduction factor* is the factor by which the actual base shear-force that would be generated if the structure were to remain elastic during its response to the Design Basis Earthquake shaking, should be reduced to obtain the design lateral force. Overstrength, redundancy and ductility together contribute to the fact that an earthquake resistant structure can be designed for much lower force than is implied by the strong shaking. The values of response reduction factor arrived at empirically based on engineering judgement are given in Table 1.16.

Table 1.16 Response Reducing Factor (*R*) for Building Systems

S. No.	Lateral Load Resisting System	<i>R</i>
<i>Building Frame Systems</i>		
1.	Ordinary RC moment-resisting frame (OMRF)	3.0
2.	Special RC moment-resisting frame (SMRF)	5.0
3.	Steel frame with	
	(a) Concentric braces	4.0
	(b) Eccentric braces	5.0
4.	Steel moment resisting frame designed as per SP 6(6)	5.0
<i>Building with Shear Walls</i>		
5.	Load bearing masonry wall buildings	
	(a) Unreinforced	1.5
	(b) Reinforced with horizontal RC bands	2.5
	(c) Reinforced with horizontal RC bands and vertical bars at corners of rooms and jambs of openings	3.0

(Contd.)

Table 1.16 (Contd.)

S. No.	Lateral Load Resisting System	R
6.	Ordinary reinforced concrete shear walls	3.0
7.	Ductile shear walls	4.0
<i>Buildings with Dual Systems</i>		
8.	Ordinary shear wall with OMRF	3.0
9.	Ordinary shear wall with SMRF	4.0
10.	Ductile shear wall with OMRF	4.5
11.	Ductile shear wall with SMRF	5.0

Notes

- The values of response reduction factors are to be used for buildings with lateral load resisting elements, and not just for the lateral load resisting elements built in isolation.
- OMRF are those designed and detailed as per IS 456 or IS 800 but not meeting ductile detailing requirement as per IS 13920 or SP 6(6) respectively.
- SMRF are those designed as OMRF and meeting the ductile detailing requirement.
- Buildings with shear walls also include buildings having shear walls and frames, but where
 - frames are not designed to carry lateral loads, or
 - frames are designed to carry lateral loads but do not fulfill the requirements of 'dual systems'.
- Reinforcement should be as per IS 4326.
- Prohibited in zones IV and V.
- Ductile shear walls are those designed and detailed as per IS 13920.
- Buildings with dual systems consist of shear walls (or braced frames) and moment resisting frames such that:
 - the two systems are designed to resist the total design force in proportion to their lateral stiffness considering the interaction of the dual system at all floor levels; and
 - the moment resisting frames are designed to independently resist at least 25 per cent of the design seismic base shear.

Fundamental Natural Period (T_a) Because the design loading depends on the building period, and the period cannot be calculated until a design has been prepared, IS 1893 (Part 1): 2002 provides formulae from which T_a may be calculated.

For a moment-resisting frame building without brick infill panels, T_a may be estimated by the empirical expression:

$$T_a = 0.075 h^{0.75} \quad \text{for RC frame building}$$

$$T_a = 0.085 h^{0.75} \quad \text{for steel frame building}$$

For all other buildings including moment-resisting frame building with brick infill panels, T_a may be estimated by the empirical expression:

$$T_a = \frac{0.09 h}{\sqrt{d}}$$

where h is height of building, in metres (this excludes the basement storeys, where basement walls are connected with the ground floor deck or fitted between the building columns. But, it includes the basement storeys, when they are not so connected), and d is the base dimension of the building at the plinth level, in metres, along the considered direction of the lateral force.

Design Response Spectrum Seismic analysis requires that the design spectrum be specified. IS: 1893 (Part 1) 2002 stipulates a design acceleration spectrum or base shear coefficients as a function of natural period. These coefficients are ordinates of acceleration spectrum divided by acceleration of gravity. Relationship holds well in single-degree systems. The spectral ordinates are used for the computation of inertia forces. Appendix V shows the plot between S_a/g and T corresponding to 5 per cent damping for rocky or hard-soil sites. Table 1.17 gives the multiplying factors for obtaining spectral values for various other damping (Note that the multiplication is not to be done for zero period acceleration). The design spectrum ordinates are independent for amounts of damping (multiplication factor 1.0), their variations from one material or one structural solution to another.

Table 1.17 *Multiplying Factor for Obtaining Spectral Values for Damping Other than 5% Damping*

Damping (Per cent)	0	2	5	7	10	15	20	25	30
Factors	3.20	1.40	1.00	0.90	0.80	0.70	0.60	0.55	0.50

Seismic Coefficient Method

This method of finding design lateral forces is also known as *static method* or *equivalent lateral load method*. The procedure does not require dynamic analysis, however, accounts for dynamics of building in approximate manner.

Design Lateral Force Buildings and their elements should be designed and constructed to resist the effects of design lateral force. The design lateral force is first computed for the building as a whole. This design lateral force is then distributed to the various floor levels. The overall design seismic force thus obtained at each floor level is then distributed to individual lateral load resisting elements depending on the floor diaphragm action.

Design Seismic Base Shear The total design lateral force or design seismic base shear (V_B) along any principal direction is determined by

$$V_B = A_h W \tag{1.5}$$

where A_h is the design horizontal acceleration spectrum value, using the fundamental natural period T_a in the considered direction of vibration; and W is the seismic weight of the building. The design horizontal seismic coefficient A_h for a structure is determined by the following expression:

$$A_h = \frac{Z}{2} \frac{I}{R} \frac{S_a}{g} \tag{1.6}$$

Note For any structure with $T \leq 0.1$ s, the value of A_h will not be taken less than $Z/2$ whatever be the value of I/R .

where Z is the zone factor given in Table 1.14. The factor 2 in the denominator of Z is used so as to reduce the Maximum Considered Earthquake (MCE) zone factor to

the factor for Design Basis Earthquake (DBE), I is the importance factor given in Table 1.15. R is the Response reduction factor given in Table 1.16.

S_a/g is the response acceleration coefficient as given in Appendix V for 5 per cent damping based on appropriate natural periods. For other damping values of the structure multiplying factors given in Table 1.17 should be used. These curves represent free field ground motion.

For rocky or hard-soil sites

$$\frac{S_a}{g} = \begin{cases} 1 + 15T; & 0.00 \leq T \leq 0.10 \\ 2.50 & 0.10 \leq T \leq 0.40 \\ 1.00/T & 0.40 \leq T \leq 4.00 \end{cases}$$

For medium soil sites

$$\frac{S_a}{g} = \begin{cases} 1 + 15T; & 0.00 \leq T \leq 0.10 \\ 2.50 & 0.10 \leq T \leq 0.55 \\ 1.36/T & 0.55 \leq T \leq 4.00 \end{cases}$$

For soft soil sites

$$\frac{S_a}{g} = \begin{cases} 1 + 15T; & 0.00 \leq T \leq 0.10 \\ 2.50 & 0.10 \leq T \leq 0.67 \\ 1.67/T & 0.67 \leq T \leq 4.00 \end{cases}$$

Seismic Weight of Floors The seismic weight of each floor is its full dead load plus appropriate amount of imposed load, the latter being that part of the imposed loads that may reasonably be expected to be attached to the structure at the time of earthquake shaking. It includes the weight of permanent and movable partitions, permanent equipment, part of live load, etc. While computing the seismic weight of each floor, the weight of columns and walls in any storey should be equally distributed to the floors above and below the storey. Any weight supported in between storeys should be distributed to the floors above and below in inverse proportion to its distance from the floors.

Seismic Weight of Building The seismic weight of the whole building is the sum of the seismic weights of all the floors.

Design Imposed Loads for Earthquakes Force Calculation

For various loading classes as specified in I.S. 875 (Part II), the earthquake force should be calculated for the full dead load plus the percentage of imposed load as given in Table 1.18. For calculating the designs seismic forces on the structure, the imposed load on roof need not be considered.

Table 1.18 Percentage of Imposed Load to be Considered in Seismic Weight Calculation

Imposed Uniformly Distributed Floor Load (kN/m ²)	Percentage of Imposed Load
Up to and including 3.0	25
Above 3.0	50

Distribution of Design Force The design base shear (V_B) is distributed to different floor levels, along the height of the building, as per the following expression:

$$Q_i = V_B \frac{W_i h_i^2}{\sum_{i=1}^n W_i h_i^2} \quad (1.7)$$

where Q_i is the design lateral force at floor i , W_i is the seismic weight of floor i , h_i is the height of floor i measured from base, and n is the number of storeys in the buildings i.e. the number of levels at which the masses are located.

Notes

1. The method of computing seismic force as discussed above is applicable to buildings not exceeding 40 m in height, in all zones. It can also be used for buildings up to 90 m high in zones I, II and III.
2. For buildings higher than 40 m in zones III, IV and V, modal analysis is done.
3. I.S. 1893 has not been revised for water tanks and bridges. Therefore, the procedure for calculating earthquake forces for these structures have been outlined according to the old code in the respective chapters.

1.12 SNOW LOAD

The snow load depends upon the latitude of the place. The design snow load depends upon the shape of the roof as well as the roofing material. This load acts vertically and may be assumed to be 2.5 N/m² per mm depth of snow.

1.13 EARTH PRESSURE

In the design of structures below ground level, e.g. basement sheet piles, retaining walls, etc. the pressure exerted by soil must be considered. Permissible bearing pressures on subsoil are given in Appendix VI. Many established theories are present, and can be used to compute the earth pressure. Due allowances should be made for possible surcharge from stationary or moving loads.

1.14 WATER CURRENT LOAD

The force exerted due to water current on the piers, abutments and other structures inside water must be taken into consideration, whenever required.

1.15 IMPACT LOAD

Impact load can be computed by multiplying live loads with the impact factors listed in Table 1.19.

Table 1.19 Impact Factors in Percentage

S. No.	Type of Structure	Impact Factor in %
1.	Frames supporting lifts and hoists	100
2.	Foundations, footings, piers supporting lifts and hoisting apparatus	40
3.	Light machinery, shaft, motor units	20
4.	Reciprocating machinery or power units	50
5.	Installed machinery	20

Temperature and Erection Effects

Due to fluctuations in temperature, the structural members expand or contract and produce some loading effects in the member, provided the ends are restrained. In a statically determinate system the influence of temperature is basically to change the member lengths and cause secondary stresses. These stresses are sometimes very prominent and may be to the order of 25% of the live loads. Therefore, for structures like bridges, trusses, etc. these must be given due considerations. Erection loads are temporary loads which come into play during construction. These also should be carefully assessed.

1.16 PERMISSIBLE STRESSES

The permissible stresses are some fraction of the yield stress of the material. It may be defined as the ratio of the yield stress to the factor of safety. I.S: 800–1984 specifies the permissible stresses in its various sections and are given in Table 1.20.

Table 1.20 Permissible Stresses in Steel Structural Members

S. No.	Types of Stress	Notation	Permissible Stress (MPa)	Factor of Safety
1.	Axial tensile stress	σ_{at}	$0.6 f_y$	1.67
2.	Maximum axial compressive stress	σ_{ac}	$0.6 f_y$	1.67
3.	Bending tensile stress	σ_{bt}	$0.66 f_y$	1.515
4.	Maximum bending compressive stress	σ_{bc}	$0.66 f_y$	1.515
5.	Average shear stress	τ_{va}	$0.4 f_y$	2.5
6.	Maximum shear stress	τ_{vm}	$0.45 f_y$	2.22
7.	Bearing stress	σ_p	$0.75 f_y$	1.33
8.	Stress in slab base	σ_{bs}	185	—

1.17 WORKING STRESSES

The stresses used in practical design are termed as working stresses or safe working stresses. These should never exceed the permissible stresses listed in Table 1.20.

1.18 FACTOR OF SAFETY

It may be defined as the ratio of strength of the member to the expected force. In other terms, when the yield point is well defined, the factor of safety is defined as the ratio of the yield stress to the maximum expected stress. The factor of safety permitted by IS: 800–84 for various stress conditions are as given in Table 1.20.

The concept of introducing a factor of safety is to make the structure safe to account for the following:

1. The analysis methods are based on assumptions and do not give the exact stresses.
2. Structural members may be temporarily overloaded under certain circumstances.
3. The stresses due to fabrication and erection are not considered in the design of ordinary structures.
4. The secondary stresses may be appreciable.
5. Underestimation of the future live loads.
6. Stress concentrations.
7. Unpredictable natural calamities.

1.19 MINIMUM THICKNESS OF STRUCTURAL MEMBERS

The minimum thickness of hot rolled sections should not be less than the limits specified in Table 1.21.

Table 1.21 Minimum Thickness of Structural Members

S.No.	Section	Directly Exposed to Weather	Accessible for Cleaning and Painting	Thickness (mm)
1.	Steel	yes	no	8
2.	Steel	no	no	6
3.	Steel	no	yes	6
4.	Tubular steel	yes	yes	4
5.	Tubular steel	no	yes	3.2
6.	Steel in webs of plate girders and crane girders	no		8

Note For steels in contact with water and soil and those subjected to alternate wetting or drying, an additional thickness of 1.5 mm is required. This aggregate thickness should not be less than the appropriate value given in Table 1.21.

1.20 DESIGN METHODS

Design of steel structures consists of the design of steel members and their connections. The design of structural steel elements is based on one or more of the following criteria:

1. Attainment of initial yielding
2. Attainment of full yielding
3. Tensile strength
4. Critical buckling
5. Maximum deflection permitted
6. Stress concentration
7. Fatigue
8. Brittle fracture

A steel structure may be designed by any one of the following methods:

1. Elastic or working stress method.
2. Plastic or limit design method.
3. Limit State method.

In the elastic method of design, the worst combination of loads is ascertained and the members are proportioned on the basis of working stresses. These stresses should never exceed the permissible ones as laid down by the code. This permissible stress will be in the elastic range of steel and will be less than the yield stress, f_y . Steel is a ductile material and from the stress-strain curve it is observed that higher loads than in the elastic method can be applied over the structure. This is due to the fact that a major portion of the curve lies beyond the elastic limit. This extra strength is termed *reserve strength* and forms the basis of plastic design method. This is an aspect of limit design, which confines the structural usefulness up to the plastic strength or ultimate load carrying capacity. In the plastic design method, the working loads are multiplied by the load factor and the members are designed on the basis of the collapse strength. The term plastic is used because, at failures, parts of the member will be subjected to very large strains—large enough to put the member into plastic range.

Limit state method also known as load and resistance factor design (LFRD) is similar to plastic design which considers most critical limit states of strength and serviceability. Load factors are applied to the service loads and then theoretical strength of the member is reduced by the application of a resistance factor. The criterion to be satisfied in the selection of member is factored load \leq factored strength.

The connection, whether riveted, bolted or welded, can be designed as flexible, semi-rigid or rigid connections. Flexible connections are also known as simple connections. These connections are assumed to resist shear only. Some insignificant bending moment may develop at the connection but a flexible connection does not provide any resistance to moment. Rigid connections, also called the moment connections, resist the shear and bending moments at the connections. Semi-rigid connections resist the bending moment in between the flexible and rigid connections. The moment resistance of such connections is less as compared to rigid connections.

Although the permissible stresses for the main member in a working stress design is based on the initial yielding of the steel, the permissible stresses for fasteners are usually based on the ultimate strength of the connection. The safety factor values of various fasteners are about 2 to 3.









The design of structural elements by elastic and plastic methods and design of connections have been discussed in subsequent chapters in detail. An introduction to limit state method of design is presented in Chapter 18 based on the draft code IS 800 which is expected shortly.

Solved Examples

Example 1.1 The yield strength for a mild steel specimen was found to be 250 N/mm^2 . Taking a factor of safety of 2, find out the working stress.

Symbols

The knowledge of rivet symbols is essential for a field engineer to read the drawings. However, in the solved examples, the symbols have not been observed strictly.

<i>Description</i>	<i>Shop rivets</i>	<i>Field rivets</i>
Round head both sides		
Countersunk near side		
Countersunk far side		
Countersunk both sides		

Rivet Material

The rivets should conform to I.S: 1929–1982 and I.S: 2155–1982 as appropriate. High tensile steel rivets should be manufactured from steel conforming to I.S: 1149–1982.

Types of Riveted Joints

There are two types of riveted joints: lap joint and butt joint.

Lap Joint The two members to be connected are overlapped and connected together. Such a joint is called a lap joint as in Fig. 2.2(a). A single riveted lap joint and a double riveted lap joint are shown in Figs 2.2(b, c) respectively. The load in the lap joint has eccentricity, as the centre of gravity of load in one member and the centre of gravity of load in the second member are not in the same line, as shown in Fig. 2.2(d). Therefore, a couple is formed which causes undesirable bending in the connection and the rivets may fail in tension. To minimise the effect of bending in lap joints at least two rivets in a line should be provided. Also, due to the eccentricity the stresses are distributed unevenly across the contact area between the rivets and members to be connected. This puts a limitation on the use of lap joints.

Butt Joint The two members to be connected are placed end to end. Additional plate/plates provided on either one or both sides, called cover plates, are placed and are connected to the main plates as in Figs 2.2(e) and (h). If the cover plate is provided on one side as in Figs 2.2(e, f) and (g), it is called a single cover butt joint but if the cover plates are provided on both the sides of main plates it is called a double cover butt joint as shown in Figs 2.2(h, i) and (j). It is more desirable to provide a butt joint than a lap joint for two main reasons:

1. In the case of double cover butt joint the total shear force to be transmitted by the members is split into two parts and the force acts on each half as shown in Fig. 2.2(k). But in the case of lap joint (Fig. 2.2(l)), there is only one plane on which the force acts and therefore the shear carrying capacity of a rivet in a butt joint is double that of a rivet in a lap joint.

2. In the case of a double cover butt joint, eccentricity of force does not exist and hence bending is eliminated, whereas it exists in the case of a lap joint.

Column	Floor No.	Live Load N/m ²	Dead Load N/m ²	Total Load from Floor N/m ²
GH	Roof	1500	3000	4500
FG	7th floor	$0.9 \times 4000 = 3600$	3000	6600
EF	6th floor	$0.8 \times 4000 = 3200$	3000	6200
DE	5th floor	$0.7 \times 4000 = 2800$	3000	5800
CD	4th floor	$0.6 \times 4000 = 2400$	3000	5400
BC	3rd floor	$0.6 \times 4000 = 2400$	3000	5400
AB	2nd floor	$0.6 \times 4000 = 2400$	3000	5400

$$\begin{aligned} \text{Design load on column BC} &= (4500 + 6600 + 6200 + 5800 + 5400) \times 4 \times 4 \\ &= 542,400 \text{ N} = 542.4 \text{ kN} \end{aligned}$$

$$\begin{aligned} \text{Design load on column AB} &= (4500 + 6600 + 6200 + 5800 + 5400 + 5400) \times 4 \times 4 \\ &= 628,800 \text{ N} = 628.8 \text{ kN} \end{aligned}$$

Example 1.4 Estimate the design wind pressure for a 100 m high lattice tower located on the outskirts of Allahabad. Estimate also the wind load in terms of the effective frontal area for the tower.

Solution For Allahabad $V_b = 47 \text{ m/s}$

$$k_1 = 1.07 \text{ (100 years)}$$

$$k_2 = 1.17 \text{ (category 2, class C)}$$

$$k_3 = 1.0 \text{ (level ground)}$$

$$V_z = V_b k_1 k_2 k_3$$

$$V_z = 47 \times 1.07 \times 1.17 \times 1.0 = 58.84 \text{ m/s}$$

Wind pressure, $p_z = 0.6 V_z^2$

$$= 0.6 \times 58.84^2 = 2077.29 \text{ N/m}^2$$

Let solidity ratio, $\phi = 0.2$

For $\phi = 0.2$, $C_f = 2.7$

Wind load, $F = C_f A_e P_d$

$$= 2.7 \times 2077.29 \times A_e$$

$$= 5608.68 A_e \text{ Newtons}$$

Example 1.5 Calculate the design wind pressure for a 12 m high water tank located in M.N.N.I.T staff colony, Allahabad.

Solution For Allahabad Zone = 2; $V_b = 47 \text{ m/s}$

$$k_1 = 1.00 \text{ (50 years)}$$

$$k_2 = 0.934 \text{ (category 3, class A)}$$

$$k_3 = 1.0 \text{ (level ground)}$$

$$V_z = V_b k_1 k_2 k_3$$

$$V_z = 47 \times 1.0 \times 0.934 \times 1.0 = 43.89 \text{ m/s}$$

Design wind pressure, $P_z = 0.6 V_z^2$

$$= 0.6 \times 43.89^2 = 1155.79 \text{ N/m}^2$$

Example 1.6 Determine the wind pressure for a bridge (100 years life), 22.5 m span, located about 20 km from Allahabad. Also, find the design wind force in terms of the width b of the bridge.

Solution For Allahabad $V_b = 47$ m/s
 $k_1 = 1.07$ (for 100 years)

For 22.5 m span bridge located in the outskirts of Allahabad

$k_2 = 1.15$ (Category 2 Class B)

$k_3 = 1.0$ (level ground)

$V_z = V_b k_1 k_2 k_3$

$$= 47 \times 1.07 \times 1.15 \times 1.0 = 57.83 \text{ m/s}$$

Design wind pressure = $0.6 V_z^2$

$$= 0.6 \times 57.83^2 = 2006.58 \text{ N/m}^2$$

For wind normal to bridge

$$F_n = C_{fn} P_d k l b \quad F_t = C_{ft} P_d k l b$$

For $\theta = 0$, and assuming double angle sections for the members from Table 1.9;

Force coefficient in the normal direction, $C_{fn} = 1.6$

Force coefficient in the transverse direction, $C_{ft} = 0.0$

Let $l/b = 5.0$; $k = 0.66$

$$\text{Wind force on the bridge, } F_n = 1.6 \times 2006.58 \times 0.66 \times 22.5 \times b \\ = 47676.34 b \text{ Newtons} = 47.67 b \text{ kN}$$

Example 1.7 A steel chimney 3.0 m in diameter is situated in a region where the intensity of wind pressure is 1200 N/m^2 . Assuming the intensity of wind pressure to be uniform, estimate the shear due to wind load at a level 15 m below the top of the chimney.

Solution Design wind load = $K P_1 A_1$

where

$K = \text{shape factor} = 0.7$

$P_1 = \text{intensity of wind pressure} = 1200 \text{ N/m}^2$

$A_1 = \text{projected area} = 3.0 \text{ m} \times 15.0 \text{ m}$

$P = 0.7 \times 1200 \times (3.0 \times 15.0)$

$$= 37,800 \text{ N} = 37.8 \text{ kN}$$

Example 1.8 The plan and elevation of a three-storey reinforced concrete school building is shown in Fig. Ex. 1.8. The building is located at Kolkata (Zone III). The type of soil encountered is medium stiff and it is proposed to design the building with special moment resisting frame. The intensity of dead load is 10 kN/m^2 and the floors are to cater imposed load of 3 kN/m^2 . Determine the design seismic loads on the structure by static analysis.

Solution

Design parameters:

For seismic zone III, Zone factor, $Z = 0.16$

Importance Factor, $I = 1.5$

Response Reduction factor, $R = 5$

Seismic Weight:

Floor Area = $8 \times 8 = 64 \text{ m}^2$

For live load up to and including 3 kN/m^2 , percentage of live load to be considered = 25%

Total seismic weight on the floors is given by $W = \Sigma W_i$ where W_i is sum of loads from all the floors which includes dead loads and appropriate percentage of live loads.

Therefore, seismic weight contribution from one floor
 $= 64 \times (10 + 0.25 \times 3) = 668 \text{ kN}$

Load from roof = $64 \times 10 = 640 \text{ kN}$

Hence, total seismic weight of the structure = $2 \times 668 + 640 = 2016 \text{ kN}$

Fundamental Natural Period of Vibration (T_a) is given by

$$T_a = \frac{0.09h}{\sqrt{d}}$$

where h is the height of the building in m and d is the base dimension in m at plinth level along the direction of the lateral force.

Since the building is symmetrical in plan, therefore, fundamental natural period of vibration will be same in both the directions.

Therefore, $T_a = \frac{0.09 \times 10.5}{\sqrt{8}} = 0.334 \text{ Sec}$

For medium stiff soil and $T_a = 0.334$; $S_d/g = 2.5$ (Appendix V)

Therefore,

$$A_h = \frac{ZI(S_d/g)}{2R} = \frac{0.16 \times 1.5 \times 2.5}{2 \times 5} = 0.06$$

Therefore, design base shear V_B ,

$$V_B = A_h W = 0.06 \times 2016 = 120.96 \text{ kN}$$

The force distribution with building height is given in Table 1.21.

Table 1.21 Lateral Load Distribution with Height

Storey Level	$W_i(\text{kN})$	$h_i(\text{m})$	$W_i h_i^2$	$\frac{W_i h_i^2}{\sum_{i=1}^n W_i h_i^2}$	Lateral Force (kN) $Q_i = V_b \frac{W_i h_i^2}{\sum_{i=1}^n W_i h_i^2}$
3	640	10.5	70560	0.626	75.72
2	688	7	33712	0.299	36.17
1	688	3.5	8428	0.0748	9.05
Σ			112700		120.94

Exercises

1.1 Find out the design load for an interior column of ground floor of an eight storey building for the following data:

- Height of each storey = 3.5 m
- Spacing of columns c/c in each direction = 3.8 m
- Live load on each floor = 2500 N/m²

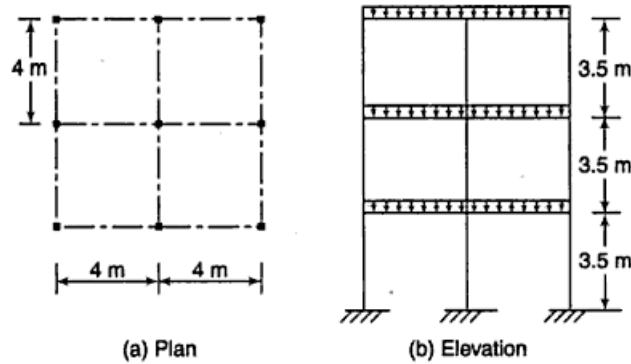

Fig. Ex. 1.8 Building Configuration

Live load on roof = 1500 N/m²
 Dead load of roof finish, slab and beam = 3000 N/m²
 (Ans. 541.5 kN)

- 1.2 A 90.0 m high chimney is to be constructed at Allahabad. The diameter of the chimney is 3.0 m. Assuming the intensity of wind pressure as 1500 N/m², estimate the design wind load at 60 m from the top of the chimney. Assume the intensity of wind pressure to be uniform over the entire height of chimney.
 (Ans. 189 kN)
- 1.3 A multistorey building is proposed in Colaba, Mumbai, where a cluster of multistorey buildings exist. Determine the design wind pressure if the return, period is 50 years, the size of the building is 25 m × 50 m and the height is 150 m.
 (Ans. 1405 N/m²)
- 1.4 A three-storey nursing home is to be built in Nainital. The size of the proposed building is 40 m × 100 m. Compute the design wind pressure on the building if the height of the building is 14 m.
 (Ans. 1234.52 N/m²)

- 1.5 A four-storey RC building is to be analysed using static lateral force method for the following data:

Concrete grade M 25,	Steel grade Fe 415
Column 300 × 450 mm,	Beam 300 × 500 mm
Slab 100 mm	
RC frame	2 bays of 5 m span each
Height of each storey	3.3 m
Imposed load	3.5 kN/m ²
Strata	Rocky
Damping	5%
Density	Masonry 20 kN/m ³
	RCC 25 kN/m ³
Thickness of infill walls	250 mm

(Ans. 104.21 kN, 100.05 kN, 44.44 kN, 11.18 kN)

Simple Connections—Riveted, Bolted and Pinned Connections

2.1 INTRODUCTION

The various elements of a steel structure like tension member, compression member and flexural member are connected by fasteners (connectors). Different types of fasteners available are rivets, bolts, pins and welds. The forces exerted by one element on another are transferred through these fasteners, which should therefore be adequate to transmit the forces safely. Often much attention is not given to the design of connections. If the necessary connections are inadequate, the result will be a poor structure in spite of the most efficiently designed member. Therefore the design of connections must be given due importance. The nature of forces and stress distributions also need to be properly evaluated and established.

Of the various types of simple connections used in structures, riveted, bolted and pinned connections behave alike, and are therefore grouped together. These are discussed in the following articles. Welded connections are discussed in Chapter 3.

2.2 RIVETED CONNECTIONS

A rivet is made up of a round ductile steel bar piece (mild or high tensile) called *shank*, with a head at one end. The head can be of different shapes as shown in Fig. 2.1(a–d). The usual form of rivet head employed in structural steel construction is the snap head. The snap heads and pan heads form a projection beyond the plate face, and where this is an objection—as in bearings, where continuity between plate and plate, or between plate and masonry, is necessary—a countersunk head is employed.

The shank is made of the length to extend through the parts to be connected and with sufficient extra length for a second head to be made at the other end. The length of the rivet to be ordered from the market is the grip of the rivet plus the extra length required to form the second head. The grip of the rivet is the distance between the underside of the two heads, i.e., the shank length inside the connection (Fig. 2.1(e)). When the grip of the rivet becomes long, the rivet is subjected to bending in addition to bearing and shearing stresses. The grip has, therefore, an important bearing upon the fixing of the rivet diameter. The grip length should not be more than 4 diameters. If the grip is more, then the diameter should be proportionately larger. The head at the other end can be formed by hand hammering (when the rivet bar is red hot), hydraulic pressure driving or by pneumatic pressure driving.

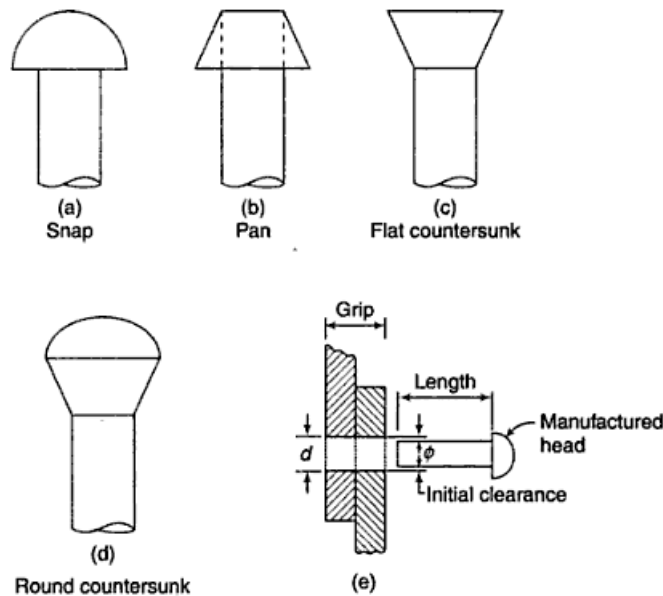

Fig. 2.1 Rivet Types, Grip and Length









The diameter of the shank is called the *nominal diameter*. A hole slightly greater than the nominal diameter is drilled in the parts to be connected. The rivet is inserted and the head is formed at the other end. This complete process is called *riveting*. The rivets may be placed in a cold state or may be heated to a red hot state. When the rivets are heated before driving they are called *hot driven field rivets* or *hot driven shop rivets*, depending upon if they are placed in the field or in the workshop. The diameter of the rivets when hot is equal to the diameter of the hole and is called *gross diameter*. The hot rivet becomes plastic, expands and fills the rivet hole completely in the process of forming a head at the other end. On cooling, the rivet shrinks both in length and diameter. Due to the shortening of the rivet shank length, the connected parts become tighter, consequently resulting in the residual tension of an unpredictable amount in the shank and some compression in the plates to be connected. The compression causes friction to slide between the plates and is called *clamping action*. Due to the reduction in diameter of the shank on cooling some space remains between the sides of the hole and the shank.

The use of cold driven rivets is limited as high pressures are required to form the head at room temperature and it may not be feasible to use the equipments for making the head in the field. The strength of the cold driven rivets is more than the hot driven rivets. Their clamping force is however less (as the rivets do not shrink) than that of hot driven rivets. The rivet heads for small diameter rivets can be formed manually with an ordinary hammer. Such rivets are called *hand driven rivets*.

The riveting process is not complete without proper inspection. The rivet placed should be tight and a proper second head concentric with the shank should be made at the other end. A defective rivet can be detected by tapping with a light hammer. If the rivet is loose, it will give a metallic or ringing sound. Such loose rivets should be detected and replaced.

Symbols

The knowledge of rivet symbols is essential for a field engineer to read the drawings. However, in the solved examples, the symbols have not been observed strictly.

<i>Description</i>	<i>Shop rivets</i>	<i>Field rivets</i>
Round head both sides		
Countersunk near side		
Countersunk far side		
Countersunk both sides		

Rivet Material

The rivets should conform to I.S: 1929–1982 and I.S: 2155–1982 as appropriate. High tensile steel rivets should be manufactured from steel conforming to I.S: 1149–1982.

Types of Riveted Joints

There are two types of riveted joints: lap joint and butt joint.

Lap Joint The two members to be connected are overlapped and connected together. Such a joint is called a lap joint as in Fig. 2.2(a). A single riveted lap joint and a double riveted lap joint are shown in Figs 2.2(b, c) respectively. The load in the lap joint has eccentricity, as the centre of gravity of load in one member and the centre of gravity of load in the second member are not in the same line, as shown in Fig. 2.2(d). Therefore, a couple is formed which causes undesirable bending in the connection and the rivets may fail in tension. To minimise the effect of bending in lap joints at least two rivets in a line should be provided. Also, due to the eccentricity the stresses are distributed unevenly across the contact area between the rivets and members to be connected. This puts a limitation on the use of lap joints.

Butt Joint The two members to be connected are placed end to end. Additional plate/plates provided on either one or both sides, called cover plates, are placed and are connected to the main plates as in Figs 2.2(e) and (h). If the cover plate is provided on one side as in Figs 2.2(e, f) and (g), it is called a single cover butt joint but if the cover plates are provided on both the sides of main plates it is called a double cover butt joint as shown in Figs 2.2.(h, i) and (j). It is more desirable to provide a butt joint than a lap joint for two main reasons:

1. In the case of double cover butt joint the total shear force to be transmitted by the members is split into two parts and the force acts on each half as shown in Fig. 2.2(k). But in the case of lap joint (Fig. 2.2(l)), there is only one plane on which the force acts and therefore the shear carrying capacity of a rivet in a butt joint is double that of a rivet in a lap joint.

2. In the case of a double cover butt joint, eccentricity of force does not exist and hence bending is eliminated, whereas it exists in the case of a lap joint.

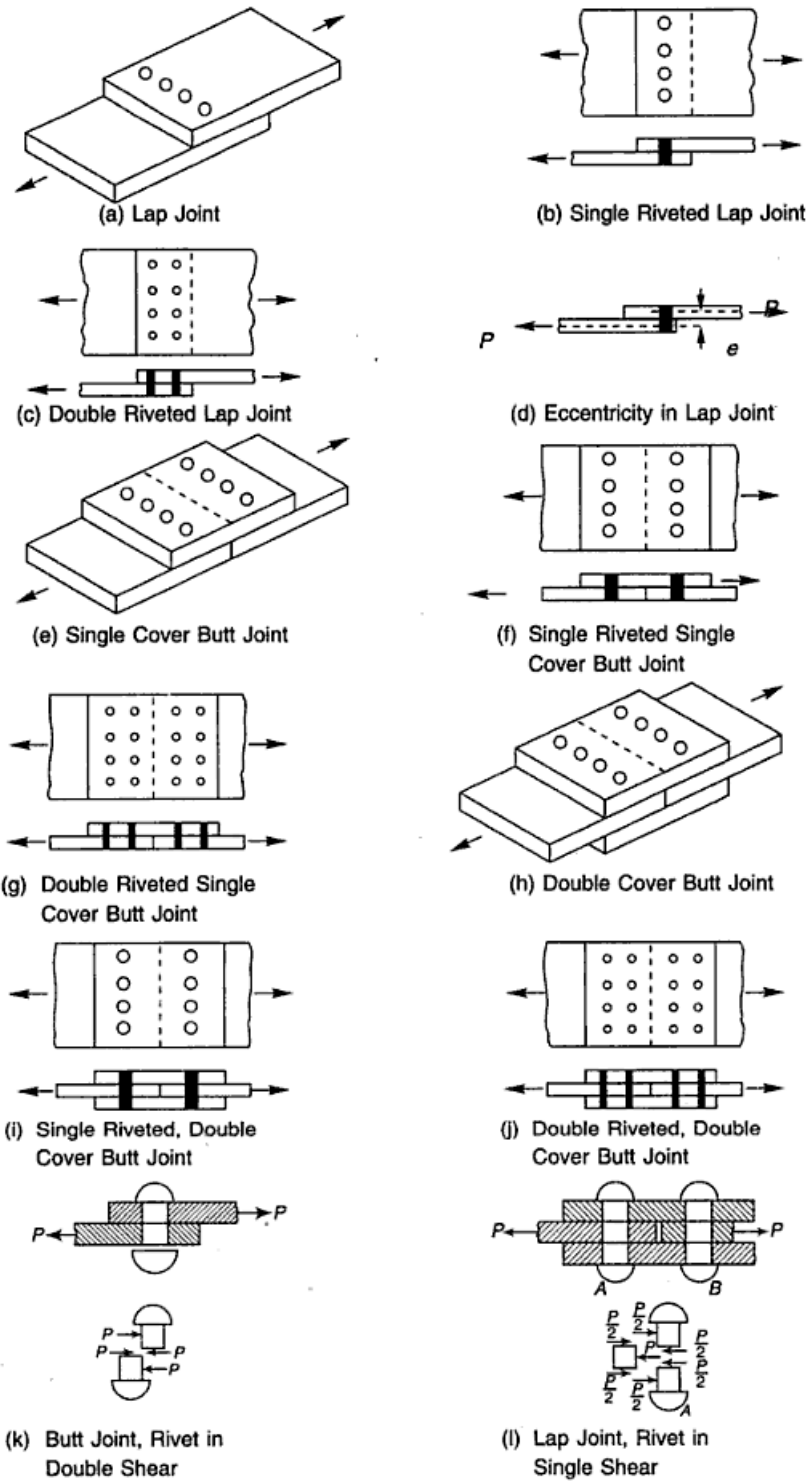

Fig. 2.2 Types of Riveted Joints

Failure of Riveted Joints

The riveted joint may fail in any of the following six ways, out of which some failures can be checked by adherence to the specifications of edge distance. Therefore, they are not of much importance, whereas the others require due consideration.

(i) *Shear Failure of Rivets* (Fig. 2.3(a)) The shear stress in the rivet may exceed the working shear stress in the rivet. Shear stresses are generated because the plates slip due to applied forces.

(ii) *Shear Failure of Plates* (Fig. 2.3(b)) The internal pressure of over driven (shank length more than the grip) rivets placed at a lesser edge distance than specified causes this failure. This can be checked by providing proper edge distance between the centre of the hole and the end of the plate as specified by I.S. 800.

(iii) *Tension or Tearing Failure of Plates* (Fig. 2.3(c)) The tensile stress in the plate at the net cross-section may exceed the working tensile stress. Tearing failure occurs when the rivets are stronger than the plates.

(iv) *Splitting of Plates* (Fig. 2.3(d)) Rivets may have been placed at a lesser edge distance than required causing the plates to split or shear out.

(v) *Bearing Failure of Plates* (Fig. 2.3(e)) The plate may be crushed when the bearing stress in the plate exceeds the working bearing stress.

(vi) *Bearing Failure of Rivets* (Fig. 2.3(f)) The rivet is crushed around the half circumference. The plate may be strong in bearing and the heaviest stressed plate may press the rivet.

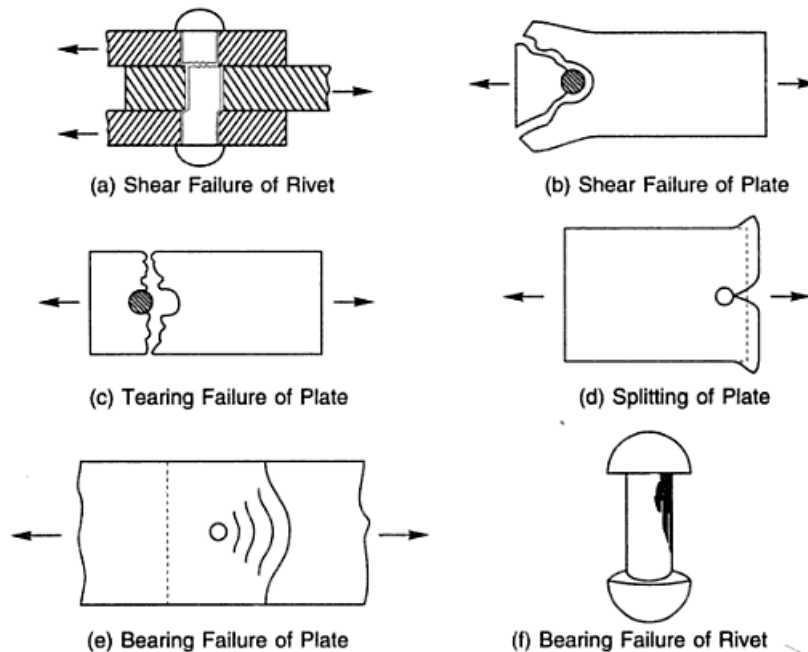

Fig. 2.3 Failure of Riveted Joints

Assumptions

Following are the assumptions made in the design of riveted joints. The assumptions are true for static loads approaching ultimate strength.

1. Rivets are Assumed to be Stressed Equally All the rivets are assumed to resist the same shear. This is true if the plates are assumed to be perfectly rigid and the rivets perfectly elastic. Actually the outer rivets are subjected to greater shear as compared to the inner rivets and the elastic stress in the members to be jointed does not remain same between two consecutive pair of rivets. Therefore the end rivets *a* and *c* shown in Fig. 2.4(a) deform more than the inner rivets *b*. The elastic stress in the top plate, between rivets *a* and *b*, is twice the elastic stress in the bottom plate and hence the upper plate stretches more between rivets *a* and *b*. Similarly the lower plate stretches more as compared to the upper plate between rivets *b* and *c*. The assumption is approximately valid when the connection is subjected to static loads approaching ultimate strength.

2. The Rivet Hole is Assumed to be Filled Completely by the Rivet The assumption is true in the case of cold driven rivets, but in the case of hot driven rivets it is not true as the rivets shrink diametrically on cooling.

3. Friction Between the Plates is Neglected The load is transmitted by friction and not by shear or bearing when the load is less than the frictional resistance of the plates. When the load exceeds the frictional resistance it is resisted partly by friction and partly by shear and bearing. Therefore the assumption is true for the kind of action that occurs near failure, when the plates have lost their clamping action because of a number of cycles of alternate loading.

4. Shear Stress is Assumed to be Uniformly Distributed Over the Gross Cross-sectional Area of the Rivet The shear stress distribution is not uniform when the loads is within elastic range, but due to the ductility of steel the shear stress distribution tends to be uniform as the load approaches the ultimate load.

5. Stress in a Plate is Assumed to be Uniform Due to the presence of holes in the plate the stress distribution is non-uniform. This is because stress concentration takes place near the holes. But as the load approaches the ultimate limit the stress approaches a uniform distribution, as shown in Fig. 2.4(b).

6. Bending of Rivet is Neglected For the design of a riveted joint, bending of the rivets is neglected. From Fig. 2.4(c) it is clear that the forces acting on a rivet can never be in a direct line and a bending moment of $3/8 Pt$ will act on the rivet, if the plates are of the same thickness. For average length rivets, it is probably permissible to neglect bending, but for ones with long grips it cannot be ignored. Bending in rivets should be accounted for if the length to diameter ratio of the rivet is more than 10.

7. Bearing Stress is Uniform Between Plates and Rivets The bearing stress is assumed to be uniform over the nominal contact surface of plates and rivets, as shown in Fig. 2.4(d). Since the rivet does not fill the hole completely the actual bearing stress distribution is not uniform. This distribution in lap and butt joints are

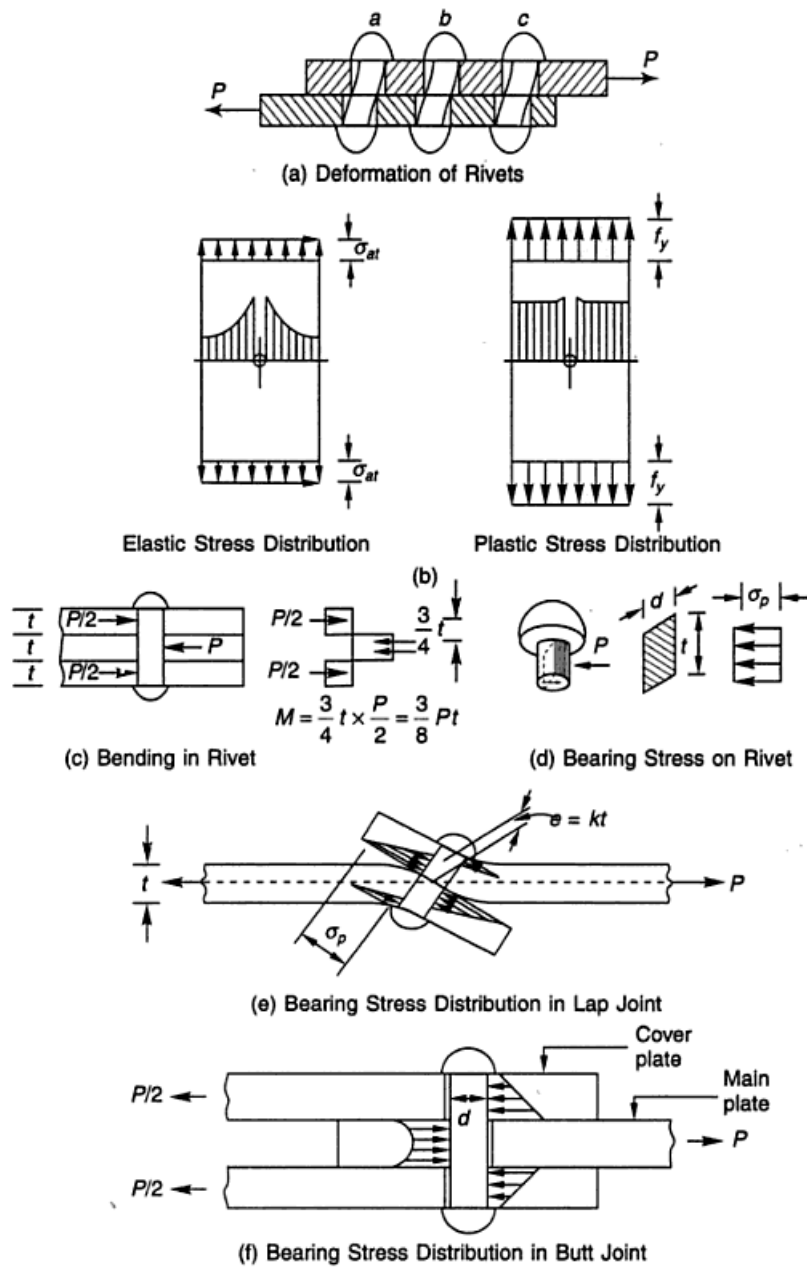

Fig. 2.4 Deformations of Rivets and Stress Distributions in Joints

shown in Figs 2.4(e, f) respectively. The bearing stress distribution is non-uniform throughout for a lap joint, whereas in the case of a butt joint it is more or less uniform for main plates, with some variations in cover plates.

Permissible Stresses

As per I.S: 800–1984, permissible stresses for mild steel rivets conforming to I.S: 1367–2002 are stated in Table 2.1. The stresses are in Mega-Pascal units. The permissible stresses in high tensile steel rivets should be the stresses in Table 2.1 multiplied by the ratio of the tensile strength of the rivet material to the tensile strength as specified in I.S: 1148–1973.

Table 2.1 Permissible Stresses in Rivets

Type of Rivet	Axial Tension (MPa)	Shear (MPa)	Bearing (MPa)
Power driven	100	100	300
Hand driven	80	80	250

Notes

- (i) For field rivets the permissible stresses are reduced by 10%.
- (ii) The calculated bearing stress of a rivet on the parts connected by it should not exceed the value of f_y (yield stress) and $1.2 f_y$ for hand driven and power driven rivets, respectively.

Specifications

To estimate the strength of the riveted joints and to ensure safe design, the specifications for pitch and edge distances as laid down by I.S: 800–1984 must be observed strictly.

(i) **Diameter** The gross diameter may be found by increasing the nominal diameter (ϕ), by certain allowances as given below.

$$\begin{aligned} \text{Gross diameter} &= \text{nominal diameter} + 1.5 \text{ mm}, & \phi \leq 25 \text{ mm} \\ \text{Gross diameter} &= \text{nominal diameter} + 2 \text{ mm}, & \phi > 25 \text{ mm} \end{aligned}$$

(ii) **Gauge (g)** is the distance between adjacent rivet lines, or the distance between the back of the rolled section and the first rivet line, or centre to centre distance (Fig. 2.5) between two consecutive rivets measured along the width of the member or connection. The gauge lines are specified on the sections tabulated in the I.S. Handbook No. 1 and the rivets should be placed on them in order to facilitate and simplify office and shop work. Gauge lines are also called the rivet lines.

(iii) **Pitch (s)** is the distance between the centre of two consecutive rivets measured along a row of rivets as shown in Fig. 2.5. A row generally refers to a line of rivets placed parallel to the stress in a member. Since the rivets are staggered the pitch in this case will be referred to as staggered pitch (Fig 2.5(a)). For wide plates (Fig. 2.5(b)) pitch may also be defined as the c/c distance of rivets measured along the length of the member or the connection. Rivets should be placed apart at a sufficient distance for the following reasons:

1. To prevent tension failure of members between the two consecutive rivets, and
2. To permit efficient installation of rivets.

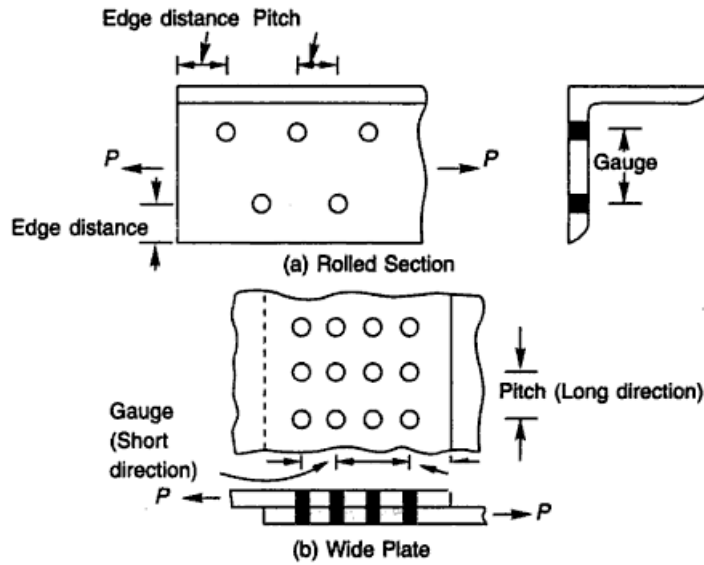

Fig. 2.5 Gauge and Pitch

It is also desirable to place the rivets sufficiently close together for the following reasons:

1. To reduce the length of the connection and gusset plate i.e. to have a compact joint, and
2. To have uniform stress in the rivets.

It is assumed that the load on the joint is distributed equally among all the rivets. This is true only when the plates are rigid, but actually the plates are elastic and deformable. If the plates are rigid, all the rivets will be stressed equally, like in Fig. 2.6(a). But as they are deformable, stresses are generated in the plates. The deformations are maximum at the ends and decrease towards the middle, as shown in Fig. 2.6(b). Rivets at the ends will be stressed more as compared to the inner ones, as the slip is more for end rivets. The variation of stress in rivets due to plate deformation will be more if the spacing of rivets i.e. pitch is more. Therefore, a compact joint is desirable to reduce the variation in rivet stress.

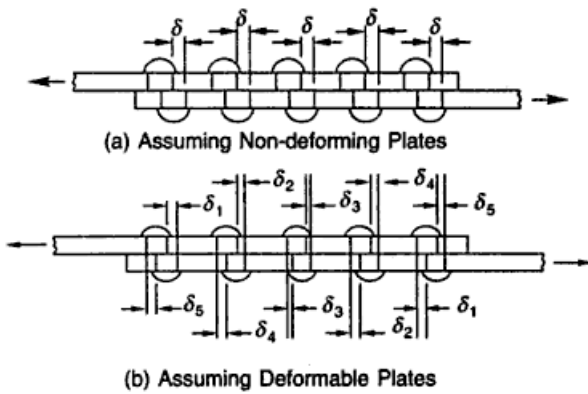

Fig. 2.6 Deformation of Rivets and Plates

Minimum Pitch The distance between centre of holes should not be less than 2.5 times the nominal diameter of the rivet. If the rivets are spaced closer than this, very little clearance is left between the last-formed rivet head and the die forming the next rivet head.

Maximum Pitch If the rivets be widely spaced or pitched, the plates, especially if thin, are apt to gap apart in the case of a built-up tension member. The same reasoning applies to a built-up compression member, but with the additional question of bulking. The various plates of a compression member, e.g., a column, strut, or the top flange of an ordinary plate web girder, become little individual columns held to the neighbouring plates by the rivet heads. The rivet heads are under tension, and wider the spacing, the greater is the load on the rivet head, tending to break it away from the shank. Again, the further apart the rivets are, the more flexible become the little columns, so that should one rivet head give way, an individual column of twice the ordinary length occurs. This may finally lead to the entire failure of the built-up member. The limits placed on maximum pitches in various cases are as follows.

1. The distance between the centre of two consecutive rivets in the direction of stress should not exceed $16t$ or 200 mm, whichever is less in tension members, and $12t$ or 200 mm, whichever is less in compression members.
In the case of compression members in which forces are transmitted through the butting face this distance should not exceed 4.5 times the diameter of the rivet and for a distance from the butting face, equal to 1.5 times the width of the members, where t is the thickness of the thinner outside plate in mm.
2. The distance between the centres of two adjacent rivets, including tacking rivets, should not exceed $32t$ or 300 mm, whichever is less.
3. The distance between the centres of any two consecutive rivets in a line adjacent and parallel to an edge of an outside plate should not exceed $(100 \text{ mm} + 4t)$ or 200 mm, whichever is less.
4. Where the rivets are staggered at equal intervals and gauge does not exceed 75 mm, the distance specified in (1) and (2) may be increased by 50%.

(iv) Edge Distance This is the distance from the centre of the rivet hole to the adjacent edge of the member (Fig. 2.5(a)). Rivet holes should not be placed too near the edges for the following reasons:

1. The failure of plate in tension may take place, and
2. The steel of the plate opposite the hole may bulge out and may crack.

The minimum distance from the centre of any hole to the edge of a plate should not be less than that given in Table 2.2. Where two or more parts are connected together a line of rivets should be provided at a distance of not more than $(37 \text{ mm} + 4t)$ from the nearest edge. If the joint is not exposed to weather the above stated limit may be increased to $12t$, where t is the thickness of the thinner outside plate.

Table 2.2 Edmm² ge Distance

Diameter of Hole (mm)	Distance to Sheared or Hand Flame Cut Edge (mm)	Distance to Rolled, Machine Flame Cut, Sawn or Planed Edge (mm)
13.5 and below	19	17
15.5	25	22
17.5	29	25
19.5	32	29
21.5	32	29
23.5	38	32
25.5	44	38
29.0	51	44
32.0	57	51
35.0	57	51

(v) **Tacking Rivets** Tacking or stitch rivets are used to make the sections act in unison, and to prevent buckling in compression members, where two or more sections are in contact.

When the distance between the centres of two consecutive rivets in such cases exceeds the maximum specified pitch of $12t$ or 200 mm, whichever is less, in compression members and $16t$ or 200 mm, whichever is less in tension members, additional rivets are provided. These are not subjected to calculated stresses and are called tacking or stitch rivets.

1. Tacking rivets should have a pitch in line not exceeding $32t$ or 300 mm, whichever is less. Where it is exposed to weather, pitch in line should not exceed $16t$ or 200 mm. In both cases, the lines of rivets should not be apart at a distance greater than these pitches.
2. For compression members maximum pitch of tacking rivets should be 600 mm.
3. In case of tension members the tacking rivets should be provided at a pitch in line not exceeding 1000 mm.

(vi) **Packings** Packings or 'filler plates' are used to make the surfaces of the main plates to be jointed, flush. In Fig. 2.7 a joint has been shown with packings. The left-hand side portion of the joint is shown with rivets which have bent due to flexure. This bending can be overcome by providing some additional rivets as shown on the right-hand side of the joint. By doing so, some of the load from the main plates is picked by the rivets on the main plates and transferred to the lengthened packing plates. This load is distributed approximately evenly throughout this

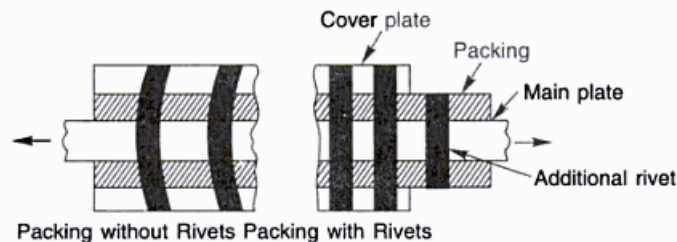
**Fig. 2.7** Bending of Rivets

extended packing plate portion. The bending action on the rivets over main joint, therefore, is reduced considerably. In fact, if the packers are carried for sufficient length ahead and attached by a corresponding number of extra rivets the bending action on the main rivets will be entirely eliminated. Therefore, extra rivets not subjected to the calculated stresses are provided on extensions of packings.

According to I.S. specifications, rivets or bolts carrying a calculated shear stress through a packing more than 6 mm thick should be increased (from the numbers of rivets require by normal calculation) by 2.5% for each 2 mm thickness of packing. The extra rivets or bolts should be placed on the packing extension. When packings are subjected only to direct compression, the specification for tacking rivets as cited here should not apply.

Strength of a Riveted Joint

Of the failures of riveted joints discussed in Section 2.2.4, the failures of plates in shear, bearing and splitting can be checked simply by providing proper edge distance. Therefore, the strength of a riveted joint is computed by considering the failure of rivets in shear and bearing and of plate in tearing only. The minimum value of these three types of failures is taken as the strength of a riveted joint.

Strength of Rivet in Shear The rivet shank shears along the plane of slip. The number of planes along which the rivet can be sheared indicates the number of shears, i.e. single or double shear (Figs 2.2(l), (k)). The resistance of a rivet to shear depends upon the cross-sectional area of the shank and the allowable unit shear stress of the rivet metal.

- Let P_s = strength of riveted joint in shear in Newton
 d = gross diameter of rivet in mm
 τ_{vf} = permissible shear stress in rivet in MPa
 n = number of rivets on each side of joint
 n' = number of rivets in one pitch length

Strength of rivet in shear = cross-sectional area \times permissible shear stress

Single shear

$$\text{Strength of one rivet} = \frac{\pi}{4} d^2 \tau_{vf} \quad (2.1)$$

$$\text{Strength of riveted joint} = n \frac{\pi}{4} d^2 \tau_{vf} \quad (2.2)$$

$$\text{Strength of riveted joint/pitch length} = n' \frac{\pi}{4} d^2 \tau_{vf} \quad (2.3)$$

Double shear

$$\text{Strength of one rivet} = 2 \frac{\pi}{4} d^2 \tau_{vf} \quad (2.4)$$

$$\text{Strength of riveted joint, } P_s = 2n \frac{\pi}{4} d^2 \tau_{vf} \quad (2.5)$$

$$\text{Strength of riveted joint/pitch length} = 2n' \frac{\pi}{4} d^2 \tau_{vf} \quad (2.6)$$

Note The shearing strength of a rivet in double shear is considered to be twice its single shear value. Any further increase of shear value beyond double shear is not permitted for rivets subjected to shear forces on more than two planes.

Strength of Rivet in Bearing The bearing strength of a rivet is the force that can be exerted on it by the section through which it passes. The bearing area of a rivet is cylindrical but for computation purpose, the projected area which is rectangular, is considered as shown in Fig. 2.4(d).

- Let P_b = strength of the riveted joint in bearing in Newtons
 d = gross diameter of the rivet in mm
 t = thickness of thinner section in lap joint or
 = thickness of main thinner plate or sum of cover plates thickness,
 whichever is minimum in butt joint
 σ_{pf} = permissible bearing stress in rivet in MPa
 n = number of rivets on each side of joint
 n' = number of rivets in one pitch length
 Strength of rivet in bearing = projected area \times permissible bearing stress
 $= dt \sigma_{pf}$ (2.7)
 Strength of riveted joint, $P_b = ndt \sigma_{pf}$ (2.8)
 Strength of riveted joint/pitch length = $n' dt \sigma_{pf}$ (2.9)

Strength of Plate in Tearing Strength of the plate in tearing depends upon the net section resisting the force. As shown in Fig. 2.8, x-x is assumed to be the critical section.

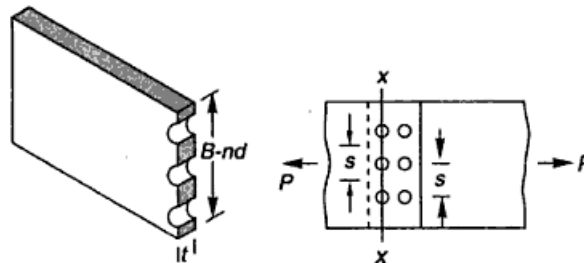

Fig. 2.8 Net Section of Plate with Chain Riveting

- Let P_t = strength of the riveted joint in tearing in Newton
 s = pitch of rivets in mm
 B = width of plate in mm
 n = number of rivets in section under consideration
 d = gross diameter of rivet in mm
 σ_{at} = permissible tensile stress in plate in MPa
 $= 0.6f_y$ (150 MPa for steel with yield stress 250 MPa)

Strength of joint at critical section, $P_t =$ net area along the section
 \times permissible tensile stress in plate

$$P_t = (B - nd)t \sigma_{at} \quad (2.10)$$

Strength of the joint/pitch length = $(s - d)t \sigma_{at} \quad (2.11)$

Note The net section in Eq. (2.11) is considered to be $(s - d)$ only because the plate tears along the critical transverse section, which is weakened by one rivet hole only. Therefore, only one rivet hole diameter is subtracted contrary to the calculations made for the computation of strength of joint/pitch length in case of shear and bearing, where the number of rivets per pitch were multiplied to the strength of one rivet.

Rivet Value (R_p) The minimum strength of a rivet in shear (Eq. (2.1)) or bearing (Eq. (2.7)) is called the rivet value.

Efficiency of riveted joint (η) This is also called the percentage strength of riveted joint. It is the ratio of the strength of the joint to the strength of the main member expressed as a percentage. The effectiveness of a particular riveted joint is measured by the efficiency.

$$\eta = \frac{\text{strength of riveted joint}}{\text{strength of solid plate}} \times 100$$

Net Section

The section available to resist the stresses, after the holes for the rivets are made, is termed as net section. The rivets may be placed in a variety of patterns, depending upon the space available for connection and the shape of members to be connected. The most common types of rivet patterns are chain riveting (Fig. 2.9(a)), and diamond riveting (Figs 2.9(c), (d)). Staggered pattern shown in Figs 2.9(b) yields more net area of the section and because of this reason this pattern is most suitable for tension members. Staggered and diamond patterns are better as compared to the chain pattern.

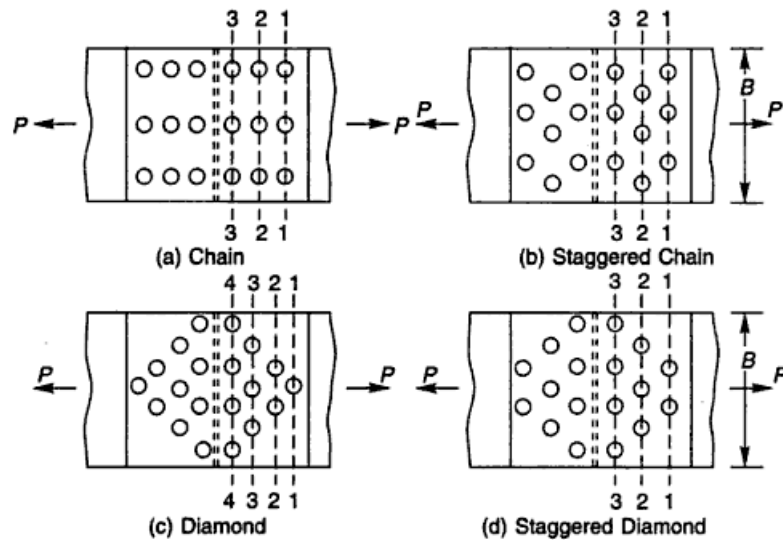

Fig. 2.9 Rivet Patterns, Shown with the Help of a Single Cover Butt Joint

Consider a single cover butt joint as shown in Fig. 2.9(c). The plates resist the total load at section 1-1 and successively lesser loads at sections 2-2, 3-3, etc. To understand this consider the butt joint shown in Fig. 2.10(a) wherein the flow of force has been shown from the main plate to the cover plate through the rivets. Force in the main plate before section 1-1 will be equal to P . As soon as it crosses section 1-1, the rivets absorb force equal to their strength and transfer it to the cover plate. Thus the force to be resisted by the main plate after section 1-1 will be less than the force at or before section 1-1. Further as it crosses section 2-2 again, there is a reduction of force in the main plate for the same reason. Therefore, it is desirable to have a less number of rivets providing more net section to resist the load at section 1-1. The number of rivets can be increased in the inward rows 2-2 and 3-3 and consequently a lesser net section may be used as the load on these sections gradually decreases. It will be reverse in the case of the cover plate where the force is maximum at section 3-3. Thus for the main plate the critical section is 1-1 and for the cover plate it is section 3-3. This can also be shown by working out the tearing strength at various sections of the chain (Fig. 2.9(a)) and diamond (Fig. 2.9(c)) patterns.

(i) For chain riveting (Fig. 2.9(a)):

$$\text{at section 1-1} = (B - 3d) t \sigma_{at} \tag{2.12}$$

$$\text{at section 2-2} = (B - 3d) t \sigma_{at} + 3 R_v \tag{2.13}$$

$$\text{at section 3-3} = (B - 3d) t \sigma_{at} + 6 R_v \tag{2.14}$$

So the critical section is 1-1 for the main plate and 3-3 for the cover plate.

(ii) For diamond riveting (Fig. 2.9(c)):

$$\text{at section 1-1} = (B - d) t \sigma_{at} \tag{2.15}$$

$$\text{at section 2-2} = (B - 2d) t \sigma_{at} + R_v \tag{2.16}$$

$$\text{at section 3-3} = (B - 3d) t \sigma_{at} + 3R_v \tag{2.17}$$

$$\text{at section 4-4} = (B - 4d) t \sigma_{at} + 6R_v \tag{2.18}$$

So the critical section is 1-1 for the main plate and 4-4 for the cover plate.

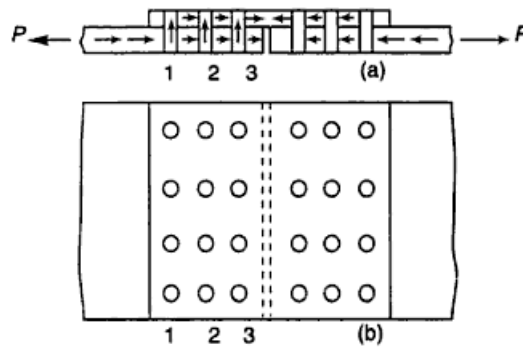

Fig. 2.10 Force Flow in a Single Cover Butt Joint

It can also be shown that the width of plate required is less if diamond rivet pattern is provided.

Let n be the number of rivets in chain riveting at the critical section 1-1, Fig. 2.9(a). The required width of the main plate is calculated from

$$P = (B - nd) t \sigma_{at} \quad \text{or} \quad B = \frac{P}{t \sigma_{at}} + nd \tag{2.19}$$

The critical section in diamond riveting will pass through one rivet hole, as in Fig. 2.9(c). The required width of the main plate is calculated from

$$P = (B - d) t \sigma_{at}$$

$$\text{or } B = \frac{P}{t \sigma_{at}} + d \quad (2.20)$$

It is clear from Eqs 2.19 and 2.20, that the width of plate required to accommodate diamond pattern is less than that for chain pattern by $d(n - 1)$. When the members are long, for instance bridge members, this reduction in width affects the economy considerably.

Staggered Pitch (s) This is also known as *alternate* or *reeled pitch*. It is the distance measured along one rivet line, from the centre of a rivet on it to the centre of the adjoining rivet on a lower and parallel rivet line, as shown in Fig. 2.11.

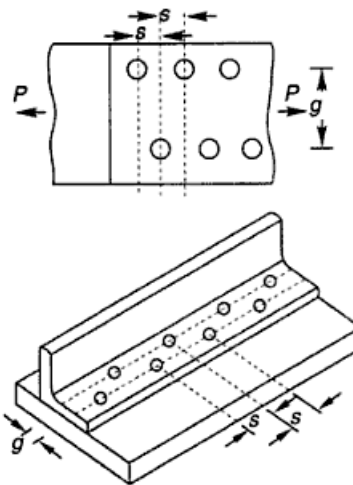

Fig. 2.11 Staggered Pitch

Design of Concentric Riveted Joint

When the line of action of a load coincides with the centre of gravity of the rivet group, the joint is said to be concentric. For such joints it is assumed that the stress is equally distributed among all the rivets. A concentric riveted joint design consists in finding out the diameter, the number or pitch of the rivets and the efficiency of the joint.

Diameter of the Rivet The size of a rivet is usually determined by considering the practical aspects of riveting as well as the strength of the structural element. It is economical to use a small number of large diameter rivets rather than a large number with small diameters. This is because for a given plate thickness, in case the shear controls the design, the strength is directly proportional to the square of the diameter of the rivet and large diameter rivets or rivets with double shear may be a choice. Whereas, if bearing controls the design, the strength is directly proportional to the rivet diameter only and in this case a large number of rivets with small diameter are preferred. The nominal diameter of a rivet is assumed to be between 12–25 mm for joining structural elements. As the range is quite large, to have an approximate value *Unwin's formula* may be used.

$$\phi = 6.01\sqrt{t}$$

where ϕ is the nominal diameter of the rivet in mm and t is the minimum thickness of the plates to be jointed, in mm. The limitation of the Unwin's formula is that it gives higher values than required. Therefore, suitable approximation may have to be made for the nominal diameter by the designer.

Number and Pitch of Rivets The number of rivets can be computed by dividing the total load to be transmitted by the rivet value. This value is the minimum strength of one rivet in shear or bearing and can be worked out as discussed in

Section 2.2.8. For a butt joint the calculated rivets are arranged on one side of the joint and the same number of rivets are also provided on the other side of the joint to make a complete joint. The pitch of the rivets should conform to the I.S. specifications, with a minimum to achieve economy and compactness. An optimum pitch of the rivets can be found by equating the tearing strength of the plates to the rivet value.

$$(s - d)t \sigma_{at} = R_v \quad (2.21)$$

Efficiency of the Joint After calculating the number of rivets and the pitch, a rivet pattern is decided and the efficiency of the joint computed, which gives an idea of the strength of the joint.

Note When the joints are subjected to reversal of stress, their frictional resistance is lost and the rivets become loose in their holes. In such cases the rivets are subjected to fatigue. To account for this, such joints are overdesigned (i.e. a larger number of rivets is provided than obtained from design) or designed for the sum of tension and compression acting on the member.

Riveted Joint in Shells

Design of riveted joint in shells consists in designing the thickness of shells, diameter of rivets and pitch. The shells can be either cylindrical or spherical. The following expressions are used for calculating stresses in shells.

Cylindrical shells

$$\text{Longitudinal stress} = \frac{pd}{4t}$$

$$\text{Circumferential stress} = \frac{pd}{2t}$$

Spherical shells

$$\text{Longitudinal stress} = \text{circumferential stress} = \frac{pd}{4t}$$

For computing the thickness of the shell the expression giving the maximum stress is used. The riveting of the shell is done in the longitudinal direction. The stress thus computed will be maximum as it is on the net section. To obtain the gross area of the section the above expressions are modified as

$$\text{Longitudinal stress} = \frac{pd}{2\eta t} \quad (\text{cylindrical shell})$$

$$= \frac{pd}{4\eta t} \quad (\text{spherical shell})$$

where p = pressure inside the shell
 d = diameter of the shell
 η = efficiency of the joint
 t = thickness of the shell

Joints of shells are designed as double cover butt joints. The efficiency of the joint in the beginning is not known; therefore, it is assumed to be between 60 – 75% for a double cover butt joint and the thickness of the main plates forming the shells is

calculated. The diameter of the rivet and a suitable pitch conforming to I.S. specifications is assumed. The rivets are placed staggered in two rows to increase the net area. The efficiency of the joint is calculated and if required, the design is revised.

2.3 BOLTED CONNECTIONS

A bolt may be defined as a metal pin with a head at one end and a shank threaded at the other end to receive a nut as in Fig. 2.12(a). Steel washers are usually provided under the bolt as well as under the nut to serve two purposes:

1. to distribute the clamping pressure on the bolted member, and
2. to prevent the threaded portion of the bolt from bearing on the connecting pieces.

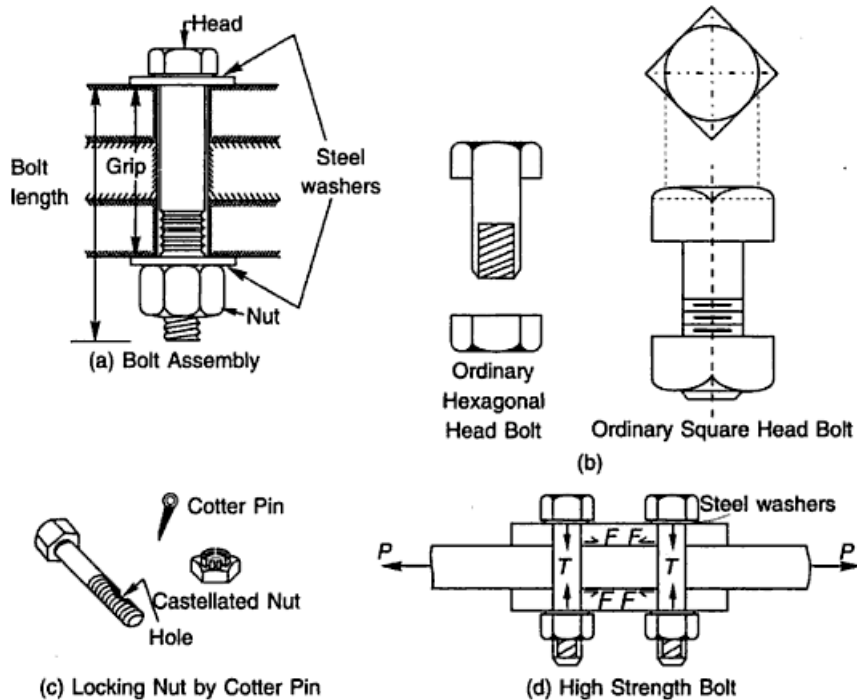

Fig. 2.12 Bolted Joints

In order to assure proper functioning of the connection, the parts to be connected must be tightly clamped between the bolt head and nut. If the connection is subjected to vibrations, the nuts must be locked in position. Bolted connections are quite similar to riveted connections in behaviour but have some distinct advantages as follows:

1. The erection of the structure can be speeded up, and
2. Less skilled persons are required.

The general objections to the use of bolts are:

1. Cost of material is high: about double that of rivets.
2. The tensile strength of the bolt is reduced because of area reduction at the root of the thread and also due to stress concentration.

3. Normally these are of a loose fit excepting turned bolts and hence their strength is reduced.
4. When subjected to vibrations or shocks bolts may get loose.

Uses

1. Bolts can be used for making end connections in tension and compression members.
2. Bolts can also be used to hold down column bases in position.
3. They can be used as separators for purlins and beams in foundations, etc.

Types There are several types of bolts used to connect the structural elements. Some of the bolts commonly used are:

- (a) Unfinished bolts
- (b) Turned bolts
- (c) Ribbed bolts
- (d) High strength bolts
- (e) Interference bolts

Unfinished Bolts

Unfinished bolts are also called ordinary, common, rough or black bolts. These are used for light structures (purlins, bracings, etc.) under static loads. They are not recommended for connections subjected to impact load, vibrations and fatigue. Bolts are forged from low carbon rolled steel circular rods, permitting large tolerances. Ordinary structural bolts are made from mild steel rods with square or hexagonal head, as shown in Fig. 2.12(b). Square heads cost less but hexagonal heads give a better appearance, are easier to hold by wrenches and require less turning space. The bolt hole is punched about 1.6 mm more than the bolt diameter. The nuts on bolts are tightened with spud wrenches, producing little tension. Therefore, no clamping force is induced on the sections jointed. Sometimes a hole is drilled in the bolt and a cotter pin with a castellated nut is used to prevent the nut from turning on the bolt, as shown in Fig. 2.12(c). The connections with unfinished bolts are designed in a similar way as all the riveted connections except that the permissible stresses are reduced to account for tolerance provided on shank and threaded portion of the bolts. The requirements regarding pitch and edge distance are same as that for rivets. The permissible stresses are as given in Table 8.1 of I.S: 800–1984.

Turned Bolts

These are similar to unfinished bolts, with the difference that the shank of these bolts is formed from a hexagonal rod. The surface of the bolts are prepared carefully and are machined to fit in the hole. Tolerances allowed are very small. These bolts have high shear and bearing resistance as compared to unfinished bolts. However, these bolts are obsolete nowadays. The specifications for turned bolts are given in I.S: 2591–1982.

Ribbed Bolts

These are also called fluted bolts. The head of the bolt is like a rivet head. The threads and nut are provided on the other end of the shank. From the shank core

longitudinal ribs project making the diameter of the shank more than the diameter of the hole. These ribs cut grooves into the connected members while tightening and ensure a tight fit. These bolts have more resistance to vibrations as compared to ordinary bolts. The permissible stresses for ribbed bolts are same as that for rivets.

High Strength Bolts

Normally, for ordinary bolted joints, the force is transferred through the interlocking and bearing of bolts. However, for high strength bolted joints this transfer of force is accomplished through the friction between the interfaces formed between load carrying elements jointed. This friction is developed by applying a load normal to the joint by tightening these bolts to proof load. That is why these bolts are also known as friction type bolts. These are made from bars of medium carbon steel. Their high strength is achieved through quenching and tempering processes or by alloying steel. Steel washers of hard steel or carburized steel are provided as shown in Fig. 2.12(d), to evenly distribute the clamping pressure on the bolted member and to prevent the threaded portion of the bolt from bearing on the connecting pieces. If the bolts are tightened by the turn of nut method, the nut is made snug and is tightened a half turn more by hand wrenches, then the washers are not required.

As the bolts are in tension up to proof load, loosening of nut and the washer is checked. Because of this property, the vibrations and impact resistance of the joint is also improved. The nut and head of the bolts are kept sufficiently large to provide an adequate bearing area. The specifications for high strength bolts are laid in I.S: 3757–1985 and I.S: 4000–1992. These bolts have a tensile strength several times that of the ordinary bolts. High strength bolts have replaced rivets and are being used in structures, such as high rise buildings, bridges, machines etc. Due to their distinct advantages and vital use, high strength bolts are discussed below in some detail.

Principle of High Strength Friction Grip Bolts The shank of the high strength bolts does not fully fill the hole. So shear and bearing are not the criteria for load transmission as is in the case of rivets, which fill the hole completely. The nut is tightened to develop a clamping force on the plates which is indicated as the tensile force T in the bolt (Fig. 2.12(d)). This tension should be about 90% of proof load. When a shear load is applied to the joint no slip will occur until the shear load exceeds the frictional resistance between the elements jointed. When the shear load exceeds the frictional resistance a slip occurs. On further increase of this load, the gradual slipping brings the bolt in contact with the plate edges.

The horizontal frictional force F , is induced in the joints which is equal to the tensile force T , as in Fig. 2.12(d), in the bolts multiplied by the coefficient of friction.

$$F = \mu T \quad (2.22)$$

This frictional force F should exceed the applied force P on the member.

μ = coefficient of friction or slip factor, is defined as ratio of the load per effective interface required to produce slip in a pure shear joint to the proof load induced in bolt. The recommended slip factors are given in Table 2.4.

Table 2.4 Slip Factors

Surface Condition (1)	Slip Factor (2)
Weathered, clear of mill scale and loose rust	0.45
Blasted with shot or grit and loose rust removed	0.50
Sprayed with aluminium	0.50
Sprayed with zinc	0.40
Treated with zinc-salient paints	0.35
Treated with etch primer	0.25
Galvanised	0.16
Dry mill scale	0.35

Table 2.5 Proof Loads for H.S.F.G. Bolts

Thread (d)	Nomimnal Stress Area mm ²	Property Class	
		8.8	10.9
		Proof Load N	
M10	58	33,700	48,100
M12	84.3	50,700	70,000
M14	115	68,800	95,500
M16	157	94,500	130,000
M18	192	115,000	159,000
M20	245	147,000	203,000
M22	303	182,000	252,000
M24	353	212,000	293,000
M27	459	275,000	381,000
M30	561	337,000	466,000
M33	694	416,000	576,000
M36	817	490,000	678,000
M39	976	586,000	810,000

Design of High Strength Friction Grip Bolts

1. The design of high strength bolts is governed by Eq. (2.22). The strength of H.S.F.G. bolt is measured by the proof load of the bolt as given in Table 2.5. This proof load is the minimum shank tension which must be applied to the bolt in order to ensure that the parts to be connected are adequately drawn together.

- Let n = number of interfaces
- F_s = factor of safety
 - = 1.4 for all loads except wind load
 - = 1.2 for wind loads
- T = proof load of one bolt

$$F = \frac{n\mu T}{F_s} \tag{2.23}$$

The diameter of the bolt is assumed and proof load is referred from I.S: 3757–1972 (Table 2.5 of the text). From Eq. (2.23) the frictional force F can be computed, and should be more than the load on the joint.

Note

1. HSFG bolts are classified as 10.9 K and 8.8 G depending upon the mechanical properties of the material from which these are formed.
2. HSFG bolts are designed by size, length, symbol and IS code number. For example, a HSFG bolt 20 mm diameter and length 120 mm, conforming to mechanical properties of 10.9 K is designed as M 20 × 120 IS: 3757–10.9 K.

2. In case the tension acts in the direction of bolt axis the clamping force is reduced. If the external tension exceeds the yield strength of the bolt shank then the plates may separate. Therefore, the external tension in the direction of the bolt shank is limited to 0.6 times the proof load of the bolts. However, if fatigue conditions are involved, the maximum permissible external tension of the bolt shank is limited to 0.5 times the proof load.

3. When connections are subjected to external tension in addition to shear, for instance in brackets, the bolts should be proportioned to satisfy the following expression:

$$\frac{\text{calculated shear}}{\text{slip factor} \times \text{number of effective interfaces}} \leq \frac{(\text{proof load} - \text{calculated tension} \times f)}{\text{factor of safety}}$$

where f = load factor, is a numerical value by which the load which would cause slip in a joint is divided to give the permissible working load on the joint. It may be taken as 2 when external tension is repetitive and 1.7 when non-repetitive.

Advantage of High Strength Friction Grip Bolts High strength friction grip bolts have replaced the rivets because of their distinct advantages as discussed below. However, the material cost is about 50% greater than that of ordinary bolts and special workmanship is required in installing and tightening these bolts.

1. These provide a rigid joint. There is no slip between the elements connected.
2. Large tensile stresses are developed in bolts, which in turn provide large clamping force to the elements connected. High frictional resistance is developed providing a high static strength of the joint.
3. Because of the clamping action, load is transmitted by friction only and the bolts are not subjected to shear and bearing.
4. The frictional resistance is effective outside the hole and therefore lesser load is transmitted through the net section. Thus, the possibility of failure at the net section is minimized.
5. There is no stress concentration in the holes; therefore, the fatigue strength is more.
6. The tension in bolts is uniform. Also the bolts are tensioned up to proof load hence, the nuts are prevented from loosening.
7. Few persons are required to make the connections, thus cost is reduced.
8. Noise nuisance is not there as these bolts are tightened with wrenches.
9. The hazard of fire is not there and there is no danger of tossing of the bolt.
10. Alterations can be done easily.
11. For same strength, lesser number of bolts are required as compared to rivets which brings overall economy.

Interference Bolts

These bolts have been developed recently and are improved high strength bolts with ribs on the shank. These have a diameter slightly more than the hole diameter. They can be installed with ordinary spud wrenches and are used for structures like towers, masts, etc. where simple tightening equipments are needed.

2.4 PIN CONNECTIONS

When two structural members are connected by means of a cylindrical shaped pin, the connection is called a pin connection. Pins are manufactured from mild steel bars with diameters ranging from 9 to 330 mm. Pin connections are provided when hinged joints are required, i.e., for the connection where zero moment or free rotation is desired. Introduction of a hinge simplifies the analysis by reducing indeterminacy. These also reduce the secondary stresses. These connections cannot resist longitudinal tension. For satisfactory working it is necessary to minimise the friction between the pin and members connected. High grade machining is done to make the pin and pin hole surface smooth and frictionless. Pins are provided in the following cases:

1. Tie rod connections in water tanks and elevated bins
2. As diagonal bracing connections in beams and columns
3. Truss bridge girders
4. Hinged arches
5. Chain-link cables suspension bridges

Various types of pins used for making the connections are forged steel pin, undrilled pin and drilled pin. To make a pin connection, one end of the bar is forged like a fork and a hole is drilled in this portion. The end of the other bar to be connected is also forged and an eye is made. A hole is drilled into it in such a way that it matches with the hole on the fork end bar. The eye bar is inserted in the jaws of the fork end and a pin is placed. Both the forged ends are made octagonal for a good grip. The pin in the joint is secured by means of a cotter pin or screw, as shown in Fig. 2.13.

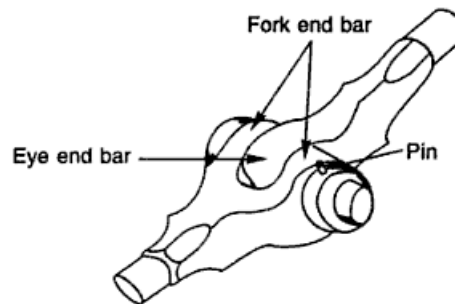

Fig. 2.13 Pin Connection

Specifications

Shear Structurally a pin may be treated as a cylindrically shaped beam. Assuming that bending does not exceed yield strength, the shear stress is maximum at the neutral axis of the pin and may be computed by beam-shear formula.

$$\tau_{vf} = \frac{V \overline{AY}}{I d}$$

or
$$\tau_{vf} = \frac{V \frac{\pi d^2}{8} \frac{2d}{3\pi}}{\frac{\pi d^4}{64} d}$$

or
$$\tau_{vf} = \frac{16V}{3\pi d^2} \tag{2.24}$$

$$\tau_{vf, \text{avg}} = \frac{3}{4} \tau_{vf} \quad \left(\tau_{vf, \text{avg}} = \frac{V}{\pi d^2 / 4} \right)$$

where τ_{vf} is the maximum shear stress in pin (100 MPa), V is the shear force at the section in Newtons, d is the diameter of the pin in mm, \bar{AY} is the moment of the area of the cross-section, above the section under consideration, about the neutral axis and I is the moment of inertia of cross-section. Calculations of shear stress from the beam-shear formula give considerable error when the span-to-depth ratio is small, as it usually is for pins. This necessitates the use of nominal shear stress based on the uniform stress distribution over the pin section, in which case $\tau_{vf, \text{avg}} = \tau_{vf} = V/A$.

Note The allowable shear stress in the pins is adopted the same as that for power driven rivets.

Bearing A pin in bearing is designed in a similar manner as for rivet. A uniform bearing stress may be assumed for a proper fit between the plates and the pin.

$$\text{Bearing force} = dt \sigma_{pf} \tag{2.25}$$

where d is the diameter of the pin in mm, t is the thickness of bar in mm and σ_{pf} is the permissible bearing stress (300 MPa).

Flexure Flexure is most critical in case of pins. The members joined by pin connections are separated some distance because of the following reasons:

1. to prevent friction
2. to allow for rivet heads, if the member is built up, and
3. to facilitate painting

Large bending moments are generated due to these reasons and the pin diameter is, therefore, generally governed by flexure. Figure 2.14(a) shows a pin connection.

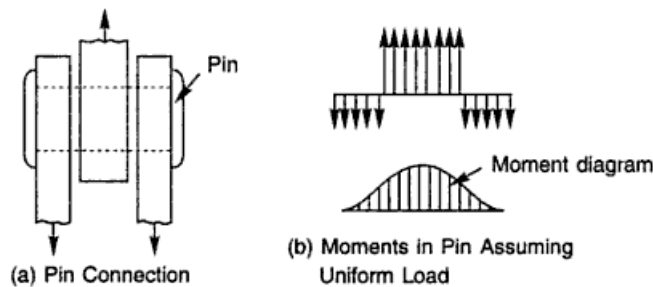

Fig. 2.14 Moment in Pin

For a given bending moment M (Fig. 2.14(b)), assuming the stress to be within the elastic limit, the maximum fibre stress can be obtained by the equation

$$M = \sigma_b Z$$

or
$$M = \sigma_b \frac{\pi d^3}{32}$$

or
$$d = \left(\frac{32M}{\pi \sigma_b} \right)^{1/3} \quad (2.26)$$

where M is the bending moment in N mm and σ_b is the bending stress ($0.66 f_y$).

Design

The design of a pin is similar to that of a rivet. A pin may be assumed to be a large rivet subjected to shear, bearing and flexure. Rivets, as we have seen, are critical in shear and bearing. On the other hand, pins are critical in flexure. Therefore, an efficient design can be obtained by determining the pin size on the basis of its bending strength.

1. The forces are calculated and points on the pin at which the forces from the members are transferred are ascertained.
2. Maximum bending moment on the pin is calculated.
3. The diameter of the pin is calculated by Eq. (2.26).
4. The average shear stress is calculated. It should be less than the allowable shear stress of 100 MPa.
5. The bearing stress is calculated. It should be less than the allowable bearing stress of 300 MPa.

Solved Examples

Example 2.1 Calculate the value of a rivet in a lap joint used to connect two plates 12 mm thick in the following cases:

- (a) Power driven rivets, and (b) Hand driven rivets

Solution Nominal diameter of rivet using Unwin's formula,

$$\phi = 6.01 \sqrt{t} = 6.01 \sqrt{12} = 20.819 \text{ mm} \approx 20 \text{ mm}$$

(Unwin's formula gives results on the conservative side. So let us adopt a rivet diameter 20 mm.)

$$\text{Gross diameter, } d = 20 + 1.5 = 21.5 \text{ mm}$$

(a) $\tau_{vf} = 100 \text{ N/mm}^2$, $\sigma_{pf} = 300 \text{ N/mm}^2$.

$$\begin{aligned} \text{Strength of rivet in single shear} &= \frac{\pi}{4} d^2 \tau_{vf} = \frac{\pi}{4} (21.5)^2 \times 100 \times 10^{-3} \\ &= 36.305 \text{ kN} \end{aligned}$$

$$\text{Strength of rivet in bearing} = dt \sigma_{pf} = 21.5 \times 12 \times 300 \times 10^{-3} = 77.400 \text{ kN}$$

Hence, the value of rivet, $R_v = 36.305 \text{ kN}$

$$(b) \tau_{vf} = 80 \text{ N/mm}^2, \sigma_{pf} = 250 \text{ N/mm}^2.$$

$$\begin{aligned} \text{Strength of rivet in single shear} &= \frac{\pi}{4} d^2 \tau_{vf} = \frac{\pi}{4} (21.5)^2 \times 80 \times 10^{-3} \\ &= 29.044 \text{ kN} \end{aligned}$$

$$\text{Strength of rivet in bearing} = dt \sigma_{pf} = 21.5 \times 12 \times 250 \times 10^{-3} = 64.5 \text{ kN}$$

Hence, the value of rivet, $R_v = 29.044 \text{ kN}$

Example 2.2 A 6 mm thick angle section is jointed to a 10 mm thick gusset plate. The angle is supporting a load of 55 kN. Find out the number of 16 mm diameter power driven rivets.

Solution Nominal diameter of rivet, $\phi = 16 \text{ mm}$

$$\text{Gross diameter of rivet, } d = 16 + 1.5 = 17.5 \text{ mm}$$

Using Power driven rivets

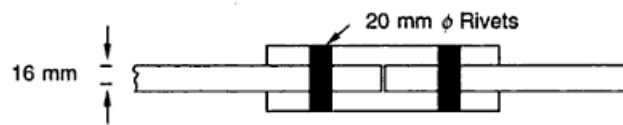

Fig. Ex. 2.3

$$\text{Strength of rivet in single shear} = \frac{\pi}{4} d^2 \tau_{vf} = \frac{\pi}{4} (17.5)^2 \times 100 \times 10^{-3} = 24.052 \text{ kN}$$

For calculating the strength of the rivet in bearing, the minimum thickness of the section to be jointed is considered.

$$\therefore t = 6 \text{ mm}$$

$$\text{Strength of rivet in bearing} = dt \sigma_{pf} = (17.5) \times 6 \times 300 \times 10^{-3} = 31.50 \text{ kN}$$

The strength of the rivet is the least of the strength in shear and bearing.

$$\therefore \text{Strength of rivet, } R_v = 24.052 \text{ kN}$$

$$\text{Number of rivets, } n = \frac{P}{R_v} = \frac{55}{24.052} = 2.2867 \approx 3$$

Provide three rivets to connect angle with gusset plate.

Example 2.3 A single-riveted double-cover butt joint is used to connect two plates 16 mm thick with chain riveting. The rivets used are power driven 20 mm in diameter at a pitch of 60 mm. Find out the safe load per pitch length and efficiency of the joint.

Solution

$$\tau_{vf} = 100 \text{ N/mm}^2, \sigma_{pf} = 300 \text{ N/mm}^2$$

$$\sigma_{at} = 0.6f_y = 150 \text{ MPa (for steel with } f_y = 250 \text{ MPa)}$$

$$\text{Nominal diameter of rivet, } \phi = 20 \text{ mm}$$

$$\text{Gross diameter of rivet, } d = 20 + 1.5 = 21.5 \text{ mm}$$

$$\text{Pitch, } s = 60 \text{ mm}$$

$$\text{Strength of rivet in double shear} = 2 \times \frac{\pi}{4} d^2 \tau_{vf}$$

$$= 2 \times \frac{\pi}{4} (21.5)^2 \times 100 \times 10^{-3}$$

$$= 72.61 \text{ kN}$$

$$\text{Thickness of cover plate} \leq \frac{5}{8} t$$

$$= \frac{5}{8} \times 16 = 10 \text{ mm}$$

Let us provide two cover plates each 10 mm thick. The thickness to be considered for calculation purposes will be the thickness of the main plate or the sum of thickness of cover plates, whichever is less.

$$\text{Strength of rivet in bearing} = dt \sigma_{pf} = 21.5 \times 16 \times 300 \times 10^{-3} = 103.200 \text{ kN}$$

$$\text{Strength of plate in tearing} = (s - d)t \sigma_{at} = (60 - 21.5) \times 16 \times 150 \times 10^{-3}$$

$$= 92.400 \text{ kN}$$

Strength of the joint per pitch length in shear is the minimum.

Hence, Strength of joint per pitch length = 72.61 kN

$$\text{Strength of solid plate per pitch length} = st \sigma_{at} = 60 \times 16 \times 150 \times 10^{-3} = 144 \text{ kN}$$

$$\text{Efficiency of joint} = \frac{\text{Strength of joint}}{\text{Strength of solid plate}} \times 100 = \frac{72.61}{144} \times 100 = 50.42\%$$

Example 2.4 Design a riveted joint to connect two plates 14 mm thick. Power driven rivets may be used for making the connection. Assume $f_y = 250 \text{ N/mm}^2$.

Solution The joint can be designed as a lap joint or as a butt joint. The design of each type of riveted joint is illustrated by this example. Finally the selection of the type of joint is done on the basis of efficiency.

The diameter of the rivet can be found by using Unwin's formula

$$\phi = 6.01 \sqrt{t} = 6.01 \sqrt{14} = 22.48 \text{ mm} \approx 22 \text{ mm}$$

(As Unwin's formula gives a higher value, provide 22 mm ϕ power driven rivets).

$$\text{Gross diameter} = 22 + 1.5 = 23.5 \text{ mm}$$

Lap joint The rivets will be in single shear

$$\text{Strength of rivet in shear} = \frac{\pi}{4} d^2 \tau_{vf} = \frac{\pi}{4} (23.5)^2 \times 100 \times 10^{-3} = 43.373 \text{ kN}$$

$$\text{Strength of rivet in bearing} = dt \sigma_{pf} = 23.5 \times 14 \times 300 \times 10^{-3} = 98.700 \text{ kN}$$

$$\text{Strength of rivet/pitch length} = 43.373 \text{ kN}$$

Let s be the pitch of rivets. For the best design, the rivets should be placed at such a pitch that the strength of rivet per pitch length is equal to the strength of plate in tearing per pitch length.

$$\text{Strength of plate in tearing} = (s - d)t \sigma_{at} = (s - 23.5) \times 14 \times 0.6 \times 250$$

$$\text{or} \quad 43.373 \times 10^3 = (s - 23.5) \times 14 \times 250$$

$$\text{or} \quad s = 44.15 \text{ mm} \approx 45 \text{ mm}$$

$$\nless 2.5\phi (= 2.5 \times 22 = 55 \text{ mm})$$

Hence, provide rivets at a pitch of 55 mm.

$$\text{Strength of the plate in tearing} = (55 - 23.5) \times 14 \times 0.6 \times 250 \times 10^{-3} = 66.150 \text{ kN}$$

$$\text{Strength of joint/pitch length} = 43.373 \text{ kN}$$

$$\begin{aligned} \text{Strength of solid plate/pitch length} &= st \sigma_{at} = 55 \times 14 \times 0.6 \times 250 \times 10^{-3} \\ &= 115.500 \text{ kN} \end{aligned}$$

$$\begin{aligned} \text{Efficiency of the joint} &= \frac{\text{strength of joint/pitch length}}{\text{strength of solid plate/pitch length}} \times 100 \\ &= \frac{43.373}{115.500} \times 100 = 37.55\% \end{aligned}$$

Butt joint

(i) *Single cover butt joint* The rivets will be in single shear.

$$\text{Strength of rivet in shear} = \frac{\pi}{4} d^2 \tau_{vf} = \frac{\pi}{4} (23.5)^2 \times 100 \times 10^{-3} = 43.373 \text{ kN}$$

$$\begin{aligned} \text{Thickness of cover plate} &\nless \frac{5}{8} t \\ &= \frac{5}{8} \times 14 = 8.75 \text{ mm} \approx 10 \text{ mm} \end{aligned}$$

The thickness of plate to be considered for bearing of rivets will be = 10 mm.

$$\text{Strength of rivet in bearing} = dt \sigma_{pf} = 23.5 \times 10 \times 300 \times 10^{-3} = 70.500 \text{ kN}$$

$$\text{Strength of rivet/pitch length} = 43.373 \text{ kN}$$

Equating the least strength of rivet to the strength of plate per pitch length in tearing,

$$43.373 \times 10^3 = (s - 23.5) \times 10 \times 0.6 \times 250$$

$$\text{or} \quad s = 52.415 \text{ mm}$$

$$\nless (2.5\phi = 2.5 \times 22 = 55 \text{ mm})$$

Hence, provide rivets at a pitch of 55 mm.

$$\text{Strength of the joint/pitch length} = 43.373 \text{ kN}$$

$$\begin{aligned} \text{Strength of solid plate/pitch length} &= st \sigma_{at} \\ &= 55 \times 10 \times 0.6 \times 250 \times 10^{-3} = 82.5 \text{ kN} \end{aligned}$$

$$\begin{aligned} \text{Efficiency} &= \frac{\text{strength of joint/pitch length}}{\text{strength of solid plate/pitch length}} \times 100 \\ &= \frac{43.373}{82.5} \times 100 = 52.57\% \end{aligned}$$

(ii) *Double cover butt joint*

The rivets will be in double shear.

$$\begin{aligned} \text{Strength of rivet in shear} &= 2 \times \frac{\pi}{4} d^2 \tau_{vf} = 2 \times \frac{\pi}{4} (23.5)^2 \times 100 \times 10^{-3} \\ &= 86.747 \text{ kN} \end{aligned}$$

The thickness to be considered for the calculation of bearing value and strength in tearing of plate is the main plate thickness or aggregate thickness of cover plates, whichever is less.

$$\begin{aligned} \therefore t &= 14 \text{ mm} \\ \text{Strength of rivet in bearing} &= dt \sigma_{pf} = 23.5 \times 14 \times 300 \times 10^{-3} = 98.70 \text{ kN} \\ \therefore \text{Strength of rivet per pitch length} &= 86.747 \text{ kN} \end{aligned}$$

Equating the strength of rivet per pitch length to the strength of plate per pitch length in tearing.

$$\begin{aligned} 86.747 \times 10^3 &= (s - 23.5) \times 14 \times (0.6 \times 250) \\ \text{or } s &= 64.80 \text{ mm} \approx 60 \text{ mm} \end{aligned}$$

$$\nless 2.5\phi = 2.5 \times 22 = 55 \text{ mm}$$

Provide rivets at a pitch of 60 mm.

$$\begin{aligned} \text{Strength of joint in tearing/pitch length} &= (s - d)t \sigma_{at} \\ &= (60 - 23.5) \times 14 \times 0.6 \times 250 \times 10^{-3} \\ &= 76.65 \text{ kN} \end{aligned}$$

$$\begin{aligned} \text{Strength of solid plate per pitch length} &= st \sigma_{at} \\ &= 60 \times 14 \times 0.6 \times 250 \times 10^{-3} \\ &= 126 \text{ kN} \end{aligned}$$

$$\begin{aligned} \text{Efficiency of joint } \eta &= \frac{\text{strength of joint per pitch length}}{\text{strength of solid plate per pitch length}} \times 100 \\ &= \frac{76.65}{126} \times 100 = 60.83\% \end{aligned}$$

From the above illustration it is clear that the efficiency of a double cover butt joint is maximum and therefore it should be preferred.

Example 2.5 A tie member has to transmit a pull of 300 kN. Design a butt joint to connect it with 12 mm thick gusset plate. Also find the efficiency of the joint. Assume steel of yield stress 250 MPa.

$$\begin{aligned} \text{Solution } \text{Nominal diameter of the rivet} &= 6.01 \sqrt{t} = 6.01 \sqrt{12} = 20.819 \text{ mm} \\ &\approx 20 \text{ mm} \end{aligned}$$

Provide 20 mm ϕ power driven rivets.

$$\text{Gross diameter of the rivet} = 20 + 1.5 = 21.5 \text{ mm}$$

$$\text{Pitch of the rivets} = 2.5 \phi = 2.5 \times 20 = 50 \approx 60 \text{ mm}$$

Let us provide a double cover butt joint. The rivets will be in double shear.

$$\begin{aligned} \text{Shear strength of one rivet} &= 2 \frac{\pi}{4} d^2 \tau_{vf} \\ &= 2 \times \frac{\pi}{4} (21.5)^2 \times 100 \times 10^{-3} = 72.61 \text{ kN} \end{aligned}$$

$$\begin{aligned} \text{Bearing strength of one rivet} &= dt \sigma_{pf} \\ &= 21.5 \times 12 \times 300 \times 10^{-3} = 77.4 \text{ kN} \end{aligned}$$

$$\text{Strength of one rivet, } R_v = 72.61 \text{ kN}$$

$$\begin{aligned} \text{Number of rivets required on each side of the butt joint} &= \frac{300}{72.61} \\ &= 4.13 \approx 5 \end{aligned}$$

Arrange the rivets as shown in Fig. Ex. 2.5.

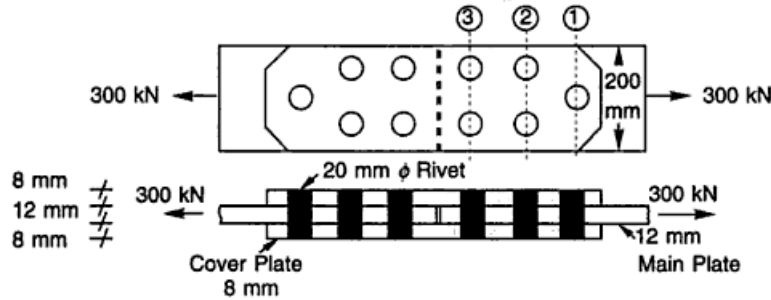

Fig. Ex. 2.5

Plate width The width of the tie plate and the thickness of the cover plate can be computed on the basis of the tearing strength of the plate section. The strength of the joint is minimum at Section (1) – (1). Therefore the width of the plate required will be maximum at Section (1) – (1). The calculations at Sections (2) – (2) and (3) – (3) have also been done to illustrate the above fact.

Let x = minimum width of the tie plate required.

Section (1) – (1)

$$(x - d)t\sigma_{at} = 300 \text{ kN}$$

or $(x - 21.5) \times 12 \times 0.6 \times 250 = 300 \times 10^3$

or $(x - 21.5) = 166.66$

or $x = 188.16 \approx 200 \text{ mm}$

Section (2) – (2)

$$(x - 2d)t\sigma_{at} + nR_v = 300 \times 10^3$$

or $(x - 2 \times 21.5) \times 12 \times 0.6 \times 250 + 1 \times 72.61 \times 10^3 = 300 \times 10^3$

or $(x - 43.0) = 126.32$

or $x = 169.32 \text{ mm}$

Section (3) – (3)

$$(x - 2d)t\sigma_{at} + nR_v = 300 \times 10^3$$

or $(x - 2 \times 21.5) \times 12 \times 0.6 \times 250 + 3 \times 72.61 \times 10^3 = 300 \times 10^3$

or $(x - 43.0) = 45.65$

or $x = 88.65 \text{ mm}$

Hence, the necessary width of the tie plate is 200 mm.

Thickness of cover plate The maximum thickness of the cover plate will be at section (3) – (3) being the critical section.

The thickness t_1 of each cover plate so calculated should not be less than $5/8$ times the thickness of the tie plate $\left(\frac{5}{8} \times 12 = 7.5 \text{ mm}\right)$.

Section (3) – (3)

$$(x - 2d) \times 2t_1 \times \sigma_{ar} = 300 \times 10^3$$

$$(200 - 43) \times 2t_1 \times 150 = 300 \times 10^3$$

or $t_1 = 6.369 \text{ mm} \approx 8 \text{ mm}$

Efficiency of joint

$$\eta = \frac{\text{strength of joint}}{\text{strength of solid plate}} \times 100$$

Tearing strength of plate at Section (1) – (1)

$$= (200 - 21.5) \times 12 \times 0.6 \times 250 \times 10^{-3}$$

$$= 321.3 \text{ kN}$$

Tearing strength of the two cover plates at Section (3) – (3)

$$= (200 - 2 \times 21.5) \times 2 \times 8 \times 0.6 \times 250 \times 10^{-3}$$

$$= 376.8 \text{ kN}$$

Hence the tearing strength of the joint = 321.3 kN

The actual safe load of the joint is the minimum of the strength in shear, bearing and tearing.

$$\text{Strength of joint in shear} = 5 \times 72.61 = 363.05 \text{ kN}$$

$$\text{Strength of joint in bearing} = 5 \times 77.4 = 387.00 \text{ kN}$$

Hence, strength of the joint = 321.3 kN

$$\text{Strength of the solid plate} = xt\sigma_{ar} = 200 \times 12 \times 0.6 \times 250 \times 10^{-3} = 360 \text{ kN}$$

$$\text{Efficiency of the joint} = \frac{321.3}{360} \times 100 = 89.25\%$$

Example 2.6 Design the joint B of a roof truss as shown in Fig. Ex. 2.6. The members are connected by power driven 20 mm ϕ rivets to a gusset plate 12 mm thick.

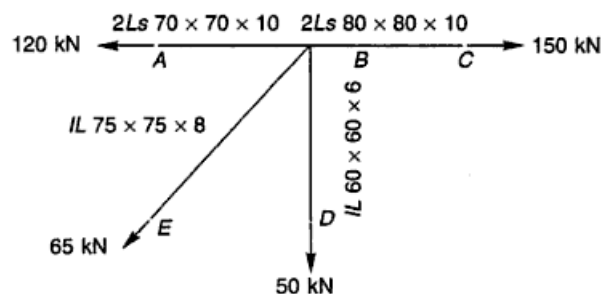

Fig. Ex. 2.6

Solution For power driven rivets

$$\tau_{vf} = 100 \text{ N/mm}^2, \quad \sigma_{pf} = 300 \text{ N/mm}^2$$

Using steel with f_y , 250 N/mm²

$$\sigma_{ar} = 0.6 \times f_y = 0.6 \times 250 = 150 \text{ N/mm}^2$$

Nominal diameter of rivet, $\phi = 20 \text{ mm}$

Gross diameter of rivet, $d = 20 + 1.5 = 21.5 \text{ mm}$

Member AB

$$P = 120 \text{ kN}$$

It is built up of 2 I.S.A. 70 mm × 70 mm × 10 mm.

The rivets will be in double shear.

$$\begin{aligned} \text{Strength of rivet in shear} &= 2 \times \frac{\pi}{4} d^2 \tau_{vf} \\ &= 2 \times \frac{\pi}{4} \times (21.5)^2 \times 100 \times 10^{-3} = 72.61 \text{ kN} \end{aligned}$$

$$\begin{aligned} \text{Strength of rivet in bearing} &= dt \sigma_{pf} \\ &= 21.5 \times 10 \times 300 \times 10^{-3} = 64.500 \text{ kN} \end{aligned}$$

Hence, strength of rivet, $R_v = 64.5 \text{ kN}$

$$\text{Number of rivets} = \frac{120}{64.5} = 1.86 \approx 2$$

Provide 2 rivets.

Member BC

$$P = 150 \text{ kN}$$

It is built up of 2 I.S.A. 80 mm × 80 mm × 10 mm.

The rivets will be in double shear.

$$\text{Strength of rivet in shear} = 72.61 \text{ kN}$$

$$\text{Strength of rivet in bearing} = 64.5 \text{ kN}$$

Hence, strength of rivet, $R_v = 64.5 \text{ kN}$

$$\text{Number of rivets} = \frac{150}{64.5} = 2.325 \approx 3$$

Provide three rivets.

Member BD

$$P = 50 \text{ kN}$$

It is built up of single I.S.A. 60 mm × 60 mm × 6 mm.

The rivets will be in single shear.

$$\begin{aligned} \text{Strength of rivet in shear} &= \frac{\pi}{4} d^2 \tau_{vf} \\ &= \frac{\pi}{4} (21.5)^2 \times 100 \times 10^{-3} = 36.305 \text{ kN} \end{aligned}$$

The thickness to be considered for bearing will be 6 mm.

$$\begin{aligned} \text{Strength of rivet in bearing} &= dt \sigma_{pf} \\ &= 21.5 \times 6 \times 300 \times 10^{-3} = 38.70 \text{ kN} \end{aligned}$$

Hence, strength of rivet, $R_v = 36.305 \text{ kN}$

$$\text{Number of rivets} = \frac{50}{36.305} = 1.377 \approx 2$$

Provide two rivets.

Member BE

$$P = 65 \text{ kN}$$

It is built up of single I.S.A. 75 mm × 75 mm × 8 mm.

The rivets will be in single shear.

$$\text{Strength of rivet in shear} = \frac{\pi}{4} d^2 \tau_{vf} = \frac{\pi}{4} (21.5)^2 \times 100 \times 10^{-3} = 36.305 \text{ kN}$$

The thickness to be considered for bearing will be 8 mm.

$$\text{Strength of rivet in bearing} = dt \sigma_{pf} = 21.5 \times 8 \times 300 \times 10^{-3} = 51.60 \text{ kN}$$

Hence, strength of rivet, $R_v = 36.305 \text{ kN}$

$$\text{Number of rivets} = \frac{65}{36.305} = 1.790 \approx 2$$

Provide two rivets.

Example 2.7 A riveted boiler 2.5 m in diameter is made with a double riveted double cover butt joint. It is subjected to a fluid pressure of 2.0 N/mm². Design the longitudinal joints of the boiler. Assume $f_y = 250 \text{ N/mm}^2$.

Solution

$$\text{Pressure } p = 2.0 \text{ N/mm}^2$$

Assume the efficiency of longitudinal joint to be 70% and allowable stress to be 120 N/mm².

$$\text{Thickness of plate} = \frac{pd}{2\eta\sigma} = \frac{2 \times 2.5 \times 10^3}{2 \times 0.7 \times 120} = 29.76 \text{ mm} \approx 30 \text{ mm}$$

Provide 30 mm thick plates for making the boiler shell.

$$\begin{aligned} \text{Actual stress in plate, } \sigma_{cal} &= \frac{pd}{2t\eta} = \frac{2.0 \times 2.5 \times 10^3}{2 \times 30 \times 0.7} = 119.04 \text{ N/mm}^2 \\ &< 120 \text{ N/mm}^2 \end{aligned}$$

which is safe.

$$\phi = 6.01\sqrt{t} = 6.01\sqrt{30} = 32.918 \text{ mm} \approx 30 \text{ mm}$$

Provide 30 mm ϕ power driven rivets.

$$\text{Gross diameter of rivets, } d = 30 + 2 = 32 \text{ mm}$$

The rivets will be in double shear as a double cover butt joint is provided. It is also double riveted; hence the strength per pitch length of rivet in shear and bearing is doubled.

$$\begin{aligned} \text{Strength of rivet in shear/pitch length} &= 2 \times 2 \times \frac{\pi}{4} d^2 \tau_{vf} \\ &= 2 \times 2 \times \frac{\pi}{4} (32)^2 \times 100 \times 10^{-3} \\ &= 321.699 \text{ kN} \end{aligned}$$

$$\begin{aligned}\text{Strength of rivet in bearing/pitch length} &= 2dt\sigma_{pf} \\ &= 2 \times 32 \times 30 \times 300 \times 10^{-3} \\ &= 576.0 \text{ kN}\end{aligned}$$

Hence, $R_v = 321.699 \text{ kN}$

The rivets are staggered so that the section is weakened by one rivet hole only.

$$\text{Tearing strength of plate/pitch length} = (s - d)t\sigma_{at} = (s - 32) \times 30 \times 150$$

Equating the tearing strength of plate/pitch length to the strength of rivet/pitch length,

$$321.699 \times 10^3 = (s - 32) \times 30 \times 0.6 \times 250$$

or $s = 103.488 \approx 100 \text{ mm}$

$$\nless 2.5 \phi (= 2.5 \times 30 = 75 \text{ mm})$$

which is all right.

$$\begin{aligned}\text{Tearing strength of plate/pitch length} &= (100 - 32) \times 30 \times 0.6 \times 250 \times 10^{-3} \\ &= 306.0 \text{ kN}\end{aligned}$$

$$\text{Strength of solid plate/pitch length} = 100 \times 30 \times 0.6 \times 250 \times 10^{-3} = 450 \text{ kN}$$

$$\eta = \frac{306}{450} \times 100 = 68\%$$

Example 2.8 A cleat angle $150 \text{ mm} \times 15 \text{ mm} \times 10 \text{ mm}$ is connected to a flange of column I.S.H.B. 450 @ 907.4 N/m through three rivets 16 mm in diameter. Find the maximum end reaction of the beam that the connection can safely carry. Assume the rivets to be power driven.

Solution From I.S. Handbook No. 1, the relevant property of I.S.H.B. 450 @ 907.4 N/m , $T = 13.7 \text{ mm}$

$$\text{Thickness of angle section} = 10 \text{ mm}$$

$$\text{Gross diameter of the rivet} = 16 + 1.5 = 17.5 \text{ mm}$$

The rivets will be in single shear.

$$\begin{aligned}\text{Shear value of one rivet} &= \frac{\pi}{4} d^2 \tau_{vf} \\ &= \frac{\pi}{4} (17.5)^2 \times 100 \times 10^{-3} = 24.05 \text{ kN}\end{aligned}$$

$$\text{Shear strength of the joint} = 3 \times 24.052 = 72.15 \text{ kN}$$

$$\begin{aligned}\text{Bearing value of one rivet} &= dt\sigma_{pf} \\ &= 17.5 \times 10 \times 300 \times 10^{-3} = 52.5 \text{ kN}\end{aligned}$$

$$\text{Bearing strength of the joint} = 3 \times 52.5 = 157.5 \text{ kN}$$

$$\text{Hence, strength of the joint} = 72.15 \text{ kN.}$$

Therefore, the joint can transfer an end reaction of 72.15 kN .

Example 2.9 Two sections 10 mm and 18 mm thick are to be jointed by double cover butt joint. The joint is double riveted with cover plates each 8 mm thick. The load to be transferred by the joint is 500 kN . Design the joint and rivets on packings.

Solution Assume nominal diameter of rivets = 20 mm

$$\text{Gross diameter} = 20 + 1.5 = 21.5 \text{ mm}$$

Assume the rivets to be power driven and steel of yield stress, $f_y = 250 \text{ MPa}$.

$$\tau_{vf} = 100 \text{ N/mm}^2, \sigma_{pf} = 300 \text{ N/mm}^2, \sigma_{at} = 0.6 \times 250 = 150 \text{ N/mm}^2$$

The joint is double cover, hence the rivets are in double shear.

$$\begin{aligned} \text{Value of rivet in double shear} &= 2 \frac{\pi}{4} d^2 \tau_{vf} \\ &= 2 \times \frac{\pi}{4} (21.5)^2 \times 100 \times 10^{-3} = 72.610 \text{ kN} \end{aligned}$$

$$\begin{aligned} \text{Value of rivet in bearing} &= dt\sigma_{pf} \\ &= 21.5 \times 10 \times 300 \times 10^{-3} = 64.50 \text{ kN} \end{aligned}$$

Hence, the rivet value is 64.50 kN.

$$\text{The number of rivets required} = \frac{500}{64.50} = 7.75 \approx 8$$

Since the joint is double riveted, provide four rivets in each row.

$$\text{Strength of rivet/pitch length} = 2 \times 64.5 = 129 \text{ kN}$$

Equating it to the strength/pitch length of the plate in tearing,

$$129 \times 10^3 = (s - 21.5) \times 10 \times 150$$

or

$$\begin{aligned} s &= 107.5 \text{ mm} \\ &\approx 105 \text{ mm} \nlessdot 2.5 \phi (2.5 \times 20 = 50 \text{ mm}) \end{aligned}$$

Provide rivets at 105 mm c/c.

Rivets on Packing The two main plates to be jointed are of different thicknesses.

$$\text{The difference in thickness} = 18 - 10 = 8 \text{ mm} > 6 \text{ mm}$$

Therefore additional rivets will have to be provided on the packing

$$\text{Additional rivets} = \frac{2.5}{100} \times \frac{8}{2} \times 7.75 = 0.775$$

Provide 2 rivets 20 mm ϕ on the packing, Fig. Ex. 2.9.

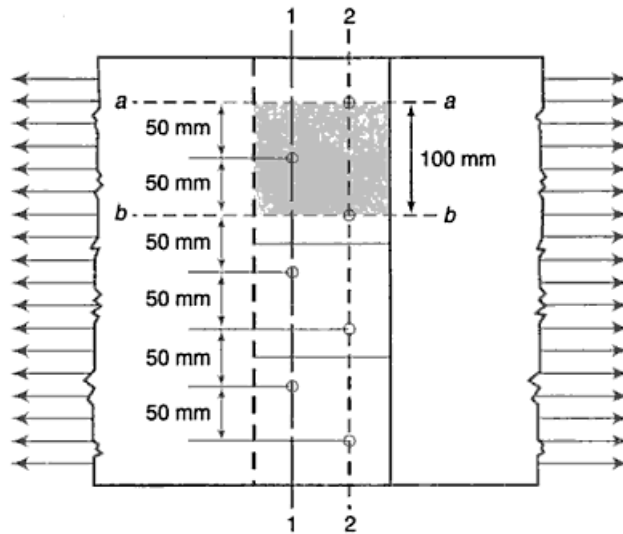

Fig. Ex. 2.9

Example 2.10 Calculate the efficiency of a zigzag double riveted lap joint to connect 10 mm thick plates with 20 mm ϕ power driven shop rivets as shown in Fig. Ex. 2.10 ($f_y = 250 \text{ N/mm}^2$)

Solution Consider a 100 mm length of the joint shaded as shown which represents typical conditions. Two rivets will fall in each pitch length formed between lines $a-a$ and $b-b$.

$$\phi = 20 \text{ mm}, d = 20 + 1.5 = 21.5 \text{ mm}$$

Fig. Ex. 2.10

Strength of rivet per pitch length in

$$\text{Single shear} = 2 \times \frac{\pi}{4} \times 21.5^2 \times 100 \times 10^{-3} = 72.61 \text{ kN}$$

$$\text{Bearing} = 2 \times 21.5 \times 10 \times 300 \times 10^{-3} = 129 \text{ kN}$$

$$\text{Strength of plate in tearing} = (100 - 21.5) \times 10 \times 0.6 \times 250 \times 10^{-3} = 117.75 \text{ kN}$$

$$\text{Strength of joint per pitch length} = 72.61 \text{ kN}$$

$$\text{Strength of solid plate per pitch length} = 100 \times 10 \times 0.6 \times 250 \times 10^{-3} = 150 \text{ kN}$$

$$\text{Efficiency of the joint} = \frac{72.61}{150} \times 100 = 48.41\%$$

Example 2.11 Determine the strength of a 20 mm diameter ordinary turned bolt if it is used to connect:

(a) Two plates each 10 mm thick

(b) Three plates, the outer two plates 8 mm thick each and the intermediate plate 14 mm thick.

$$\tau_{vf} = 100 \text{ N/mm}^2, \quad \sigma_{pf} = 300 \text{ N/mm}^2$$

Solution

$$\begin{aligned} \text{(a) Strength of bolt in single shear} &= \frac{\pi}{4} d^2 \tau_{vf} \\ &= \frac{\pi}{4} (20)^2 \times 100 \times 10^{-3} = 31.415 \text{ kN} \end{aligned}$$

$$\text{Strength of bolt hole in bearing} = 20 \times 10 \times 300 \times 10^{-3} = 60 \text{ kN}$$

Hence, strength of the bolt = 31.415 kN.

$$\begin{aligned} \text{(b) Strength of bolt in double shear} &= 2 \times \frac{\pi}{4} d^2 \tau_{vf} \\ &= 2 \times \frac{\pi}{4} (20)^2 \times 100 \times 10^{-3} = 62.830 \text{ kN} \end{aligned}$$

$$\begin{aligned}\text{Strength of bolt hole in bearing} &= dt \sigma_{pf} \\ &= 20 \times 14 \times 300 \times 10^{-3} = 84 \text{ kN}\end{aligned}$$

Hence, strength of the bolt = 62.830 kN

Example 2.12 Design a butt joint to connect two plates 240×12 mm ($f_y = 250$ N/mm²) using ordinary M20 bolts. Arrange the bolts to give maximum efficiency.

Solution Let us provide a double cover butt joint.

$$\text{Thickness of cover plate} = \frac{5}{8} \times 12 = 7.5 \text{ mm} = 8 \text{ mm}$$

The tensile force (T) the main plate can carry

$$= bt \sigma_{at} = 240 \times 12 \times 0.6 \times 250/10^3 = 432 \text{ kN}$$

$$\text{Shear strength of bolt} = 2 \frac{\pi}{4} d^2 \tau_{vf}$$

$$= 2 \times \frac{\pi}{4} \times 20^2 \times 80/10^{-3} = 50.265 \text{ kN}$$

$$\text{Bearing strength of bolt} = dt \sigma_{pf}$$

$$= 20 \times 12 \times 250 \times 10^{-3} = 60 \text{ kN}$$

Hence, strength of the bolt = 50.265 kN

$$\text{Number of bolts required} = \frac{432}{50.265} = 8.594 \approx 9$$

Provide a diamond joint as shown in Fig. Ex. 2.12.

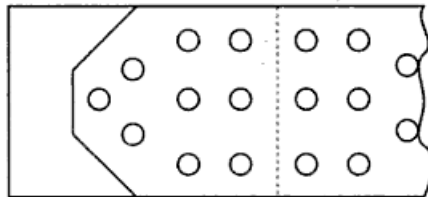

Fig. Ex. 2.12

Example 2.13 An ISA $100 \times 100 \times 10$ mm is subjected to a tension of 66 kN. It is to be jointed to a 12 mm thick gusset plate. Design a high strength bolted joint.

Solution Design load = 66 kN

$$F = \frac{n \mu t}{F_s}$$

$$66 = \frac{1 \times 0.5 \times T}{1.4}$$

Proof load, $T = 184.8$ kN

The bolts are under single shear. Let us try High Strength M 14–8.8 G bolts. From Table 2.5, the proof load for the bolt is 68.8 kN.

$$\text{Number of bolts required} = \frac{184.8}{68.8} = 2.68 \approx 3$$

Use 3, High Strength M 14–8.8 G bolts.

Example 2.14 Design a bolted connection using HSFG bolts to connect flange of the bracket-Tee with the column flange as shown in Fig. Ex. 2.14. The double angle tie member is connected to the web of Tee bracket as shown in the Fig. Ex. 2.14 Assume a slip factor of 0.5.

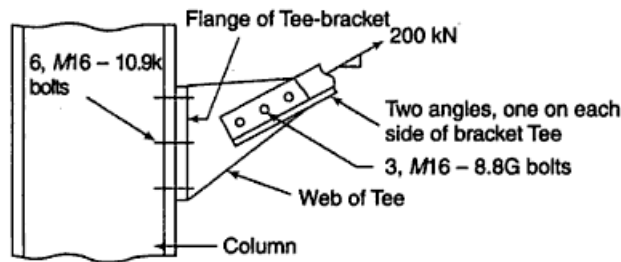

Fig. Ex. 2.14

Solution

Connection of tie member with Tee-bracket

There are two interfaces.

Member force = 200 kN

$$F = \frac{n\mu T}{F_s}$$

$$200 = \frac{2 \times 0.50 \times T}{1.4}$$

Proof load, $T = 280.0$ kN

Let us try M 16–8.8 G bolts

The proof load for the above bolt is 94.5 kN.

$$\text{Number of bolts required} = \frac{280.0}{94.5} = 2.96 \approx 3$$

Provide 3 M 16–8.8 G HSFG bolts for making the connection.

Connection of Tee-bracket with column flange

$$\text{Tension on the connection} = 200 \times \frac{4}{5} = 160 \text{ kN}$$

$$\text{Shear on the connection} = 200 \times \frac{3}{5} = 120 \text{ kN}$$

Let us try total 6 HSFG M 16–10.9 K bolts, three on each part of the Tee-flange on the two sides of the bracket web.

$$\text{Tension per bolt} = \frac{160}{6} = 26.66 \text{ kN}$$

$$\text{Shear per bolt} = \frac{120}{6} = 20 \text{ kN}$$

There is only one interface

$$\frac{\text{calculated shear}}{\text{slip factor} \times \text{number of interfaces}} = \frac{\text{proof load} - \text{calculated tension}}{\text{factor of safety}}$$

$$\frac{20}{0.50} = \frac{\text{proof load} - 26.66 \times 1.7}{1.4}$$

$$\text{Proof load} = 101.32 \text{ kN} < 130 \text{ kN}$$

Provide 6 HSFG bolts M 16–10.9 K

Example 2.15 Design a pin for the tension link shown in Fig. Ex. 2.15. The plate sections ($f_y = 250 \text{ MPa}$) are as shown.

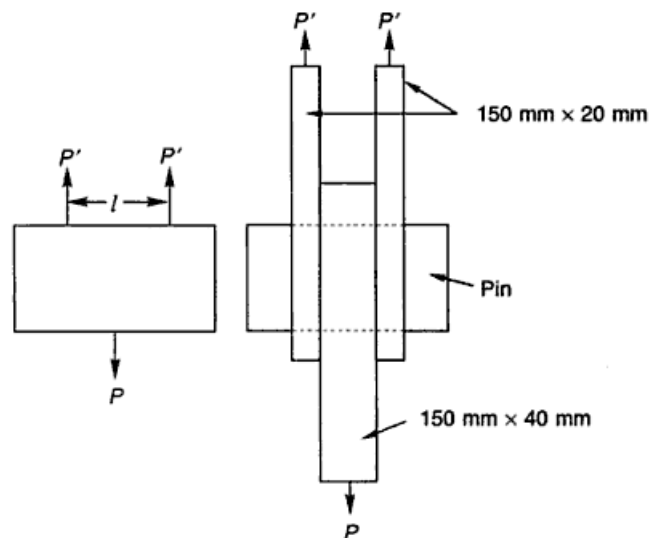

Fig. Ex. 2.15

Solution Pull transmitted by each 20 mm plate:

$$P' = \sigma_{at} bt = 0.6 \times 250 \times 150 \times 20 = 450 \times 10^3 \text{ N}$$

$$P = 0.6 \times 250 \times 150 \times 40 \times 10^3 = 900 \text{ kN}$$

$$\begin{aligned} \text{Maximum bending moment} &= \frac{Pl}{4} \\ &= \frac{900 \times 10^3 \times (40 + 10 + 10)}{4} \end{aligned}$$

$$\therefore = \frac{900 \times 10^3 \times 60}{4} \text{ N mm}$$

$$\begin{aligned} d &= \left(\frac{32 M}{\pi \sigma_b} \right)^{1/3} = \left(\frac{32 \times 900 \times 10^3 \times 60}{4 \times \pi \times 0.66 \times 250} \right)^{1/3} \\ &= 94.10 \text{ mm} \approx 100 \text{ mm} \end{aligned}$$

Provide a 100 mm diameter pin.

Check

(i) Average shear stress in pin,

$$\tau_{vf} = \frac{450 \times 10^3}{\frac{\pi}{4} (100)^2} = 57.29 \text{ N/mm}^2 < 100 \text{ N/mm}^2$$

which is as it should be.

(ii) Bearing stress in the pin,

$$\sigma_{pf} = \frac{450 \times 10^3}{100 \times 20} = 225 \text{ N/mm}^2 < 300 \text{ N/mm}^2$$

which is all right.

Example 2.16 Design a pin to connect two pairs of parallel 175 mm × 40 mm eye bars ($f_y = 250$ MPa) as shown in Fig. Ex. 2.16.

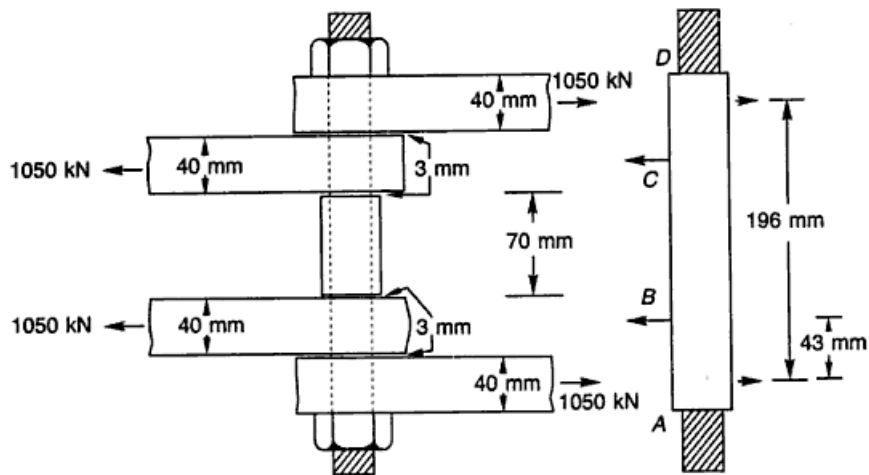

Fig. Ex. 2.16

Solution Maximum tension in eye bar = $175 \times 40 \times 150 \times 10^{-3} = 1050$ kN

Maximum bending moment will be at B and C.

Maximum bending moment = $1050 \times 43 = 45,150$ kN mm

$$d = \left(\frac{32 \times M}{\pi \times \sigma_{bt}} \right)^{1/3} = \left(\frac{32 \times 45,150 \times 10^3}{\pi \times 0.66 \times 250} \right)^{1/3} \\ = 140.73 \text{ mm} \approx 150 \text{ mm}$$

Check in shear $\tau_{vf} = \frac{1050 \times 10^3}{\frac{\pi}{4} \times 150^2} = 59.4178 \text{ N/mm}^2 < 100 \text{ N/mm}^2$

which is all right.

Check in bearing

$$\sigma_{pf} = \frac{1050 \times 10^3}{150 \times 40} = 175 \text{ N/mm}^2 < 300 \text{ N/mm}^2$$

which is as it should be.

Exercises

Note Use the steel of yield stress 250 MPa if not specified in the problem.

- 2.1 Compute the value of rivet, 22 mm in diameter, used to connect two plates 12 mm thick in the following cases:
 - (a) Power driven rivets
 - (b) Hand driven rivets
- 2.2 Determine the safe load and the efficiency of a double cover butt joint. The main plates are 14 mm thick connected by 18 mm diameter rivets at a pitch of 100 mm. Design the cover plates also. What is the percentage reduction in the efficiency of the joint if the plates are lap jointed?
- 2.3 A water tank is made with 10.0 mm thick plates. The plates are jointed by a lap jointed using 18 mm diameter rivets at a pitch of 60 mm. Find the efficiency of the joint if the rivets are power driven.
- 2.4 Design a riveted joint to connect an angle section tension member 80 mm × 80 mm × 8 mm to a gusset plate 12 mm thick. The member is to carry a load of 100 kN.
- 2.5 A tension member consists of an I.S.M.C. 200 @ 216.8 N/m. It is to be connected to a gusset plate. Design riveted connections to develop the full tensile strength of the member. Assume yield stress of steel 230 MPa.
- 2.6 Design a double cover butt joint to connect two plates each 12 mm thick. The load to be transferred by the joint is 400 kN.
- 2.7 Two plates 12 mm thick are connected by a double riveted lap joint. Power driven 16 mm diameter rivets at 60 mm pitch are provided. Find the load carrying capacity and the efficiency of the joint.
- 2.8 Design the joints of members of a roof truss with the gusset plate 12 mm thick as shown in Fig. Prob. 2.8.

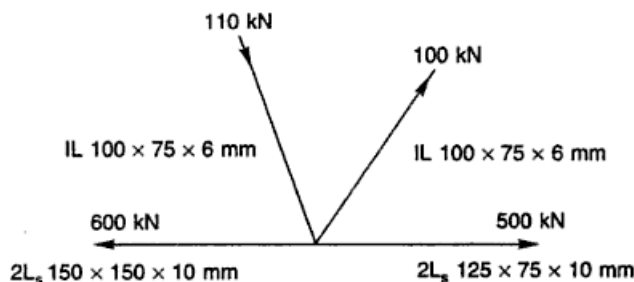

Fig. Prob. 2.8

- 2.9 A riveted boiler 2400 mm in diameter is subjected to a fluid pressure of 2 N/mm². Design the longitudinal joints of the boiler.

- 2.10 Design the foundation bolts for a steel chimney. The uplift on the wind-ward side of the 4.0 m diameter chimney is 358 N/mm on its periphery at the base.
- 2.11 Design the foundation bolts of a gusset base foundation, subjected to a tension of 70 kN.
- 2.12 A column ISHB 200 @ 392.4 N/m carries a axial compressive load of 380 kN. Design the connections of the gusset material with the column section using HSFG bolts.
- 2.13 Design a lap joint to connect two plates 16 mm thick using high strength friction grip bolts.
- 2.14 Design a pin connection to connect two pairs of parallel eye bars 200 mm × 50 mm. The inner pair of eye bars is spaced 80 mm apart.

Simple Connections— Welded Connections

3.1 INTRODUCTION

When two structural members are jointed by means of welds the connection is called a welded connection. A few decades ago designers had a feeling that welded connections were less fatigue resistant and that a good quality welded connection could not be made. These negative feelings had a great impact on the use of welding in structures. But the progress made in welding equipment and electrodes, the advancing art and science of designing for welding, and the increasing trust and acceptance of welding have combined to make it a powerful implement for the expanding construction industry.

The economics inherent in welding are helping to offset increase in the prices of material and cost of labour. In addition, the shortened production cycles made possible by welding, have helped effect a quickening in the pace of new construction. Welding will become increasingly important as more people acquire a greater depth of knowledge and experience that goes with it. Today most of the regulatory agencies and government departments accept welded joints.

There are a number of reasons for using a welded design, but a few basic ones are:

1. Welded designs offer the opportunity to achieve a more efficient use of materials. Welding is the only process that produces a one piece construction.
2. The speed of fabrication and erection helps compress production schedules.

Welding permits architects and structural engineers complete freedom of design. The usage of outstanding design advancements such as open-web expanded (castellated) beams, tapered beams, vierendeel trusses, cellular floor construction, tubular column and trusses are a few examples of welded constructions.

A properly welded joint is stronger than the material jointed. Fused joints create a rigid structure in contrast to the non-rigid structures made using other type of joints. The compactness and greater rigidity of welded joints permits design assumptions to be realised more accurately. Welded joints are better for fatigue loads, impact loads and vibrations.

Welding saves weight and consequently cuts costs. Connecting steel plates are reduced or eliminated since they often are not required. No deductions are there for holes; thus the gross section is effective in carrying loads.

Welding offers the best method for achieving a rigid connection, resulting in reduced beam depth and weight. Thus it noticeably lowers the overall height of a

building. The weight of the structure and consequently the static loading is considerably reduced. This saves column steel and reduces foundation requirements. Saving in transportation, handling time and erection is proportional to the weight savings.

3.2 TYPES

The basic types of welding joints can be classified depending upon the *type of weld*, e.g., fillet weld, butt or groove weld, plug weld, slot weld, spot weld, etc., *position*, e.g., flat weld, horizontal weld, vertical weld and overhead weld, etc., and *type of joint*, e.g., butt weld, lap weld, tee weld and corner weld. The various types of welds are shown in Fig. 3.1.

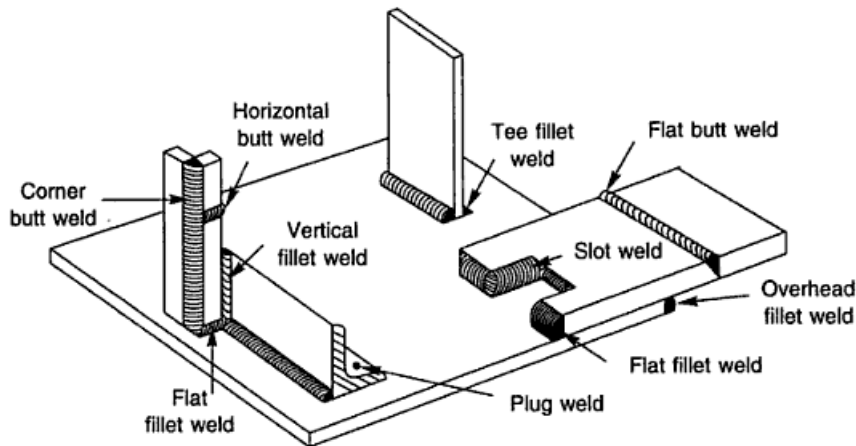

Fig. 3.1 Types and Positions of Welds

Fillet and butt welds are most frequently used. Butt welds, are provided when the members to be jointed are lined up. Various types of butt welds are shown in Fig. 3.2. Single V, U, J, etc. are cheaper to form, but require double the weld metal than double grooved joints. The choice between single and double grooves is usually a question of whether the higher cost of preparation is offset by the saving in weld metal. Fillet welds are provided when two members to be jointed are in different planes. This situation is frequently met within structures. Therefore, fillet welds are more common than butt welds. Various types of fillet welds are shown in Fig. 3.3.

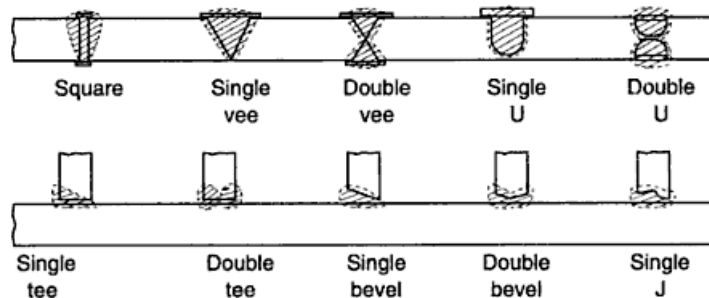

Fig. 3.2 Types of Butt Welds

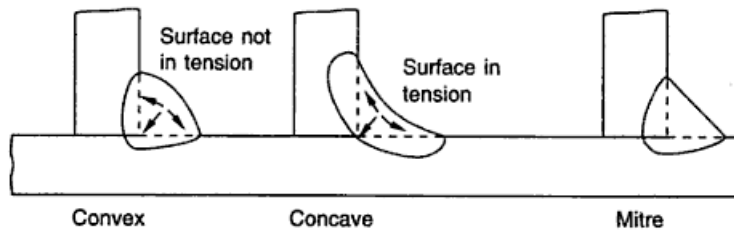

Fig. 3.3 Types of Fillet Weld

Fillet welds are normally easier to make, require less material preparation, and are easier to fit than butt welds. On the other hand, for a given amount of weld material, they are not as strong and they cause greater concentration of stress. In lightly stressed structures where stiffness rather than strength controls design and fatigue or brittle fracture is not a problem, fillet welds are entirely adequate and generally more economical. Reliable fillet welds may be, and frequently are, designed for severe stress and service conditions, but, as a rule, butt welds are better in highly stressed structures where smooth flow of stress is necessary. If the butt joint has the same characteristics as the parent metal, is finished smooth with it on both sides (by proper grinding or the like), and has complete penetration with no unweld zones, it approaches the condition of no joint at all and, for most common types of parent metal, may have impact and fatigue resistance equal or superior to that of the base metal.

3.3 SYMBOLS

A knowledge of welding symbols is essential for a site engineer to be able to read the drawings. Symbols save a lot of space as descriptive notes can be omitted.

Table 3.1 depicts the symbols and the method of their representation on the drawings. The drawings need to indicate the side of welding, size, contour and finish, spacing and whether it is field or shop weld. Some examples of symbols and dimensions of welds are shown in Table 3.2 and 3.3, respectively.

Table 3.1 Description of Type of Weld and its Representation

Type of weld												
Filler	Butt							Seam	Spot	Plug	Field weld	
	Square	V	Bevel	U	J	V with broad root face	Bevel with broad root face	Weld with raised edges				
Shape of weld surface		Symbol		Method of representation								
Flat (usually finished flush)												
Convex												
Concave												

Notes

1. The position of the arrow line with respect to the weld is generally not significant.
2. The reference line should be a straight line preferably drawn parallel to the bottom edge of the drawing.
3. The symbol is placed on the continuous line side of the reference line if the weld is on the arrow side of the joint.
4. The symbol is placed on the broken line side if the weld is on the other side of the joint.

Table 3.2 Examples of Use of Main and Supplementary Symbols for Welds











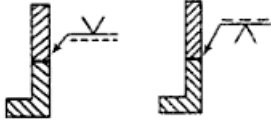

S. No.	Designation symbol	Illustration	Symbolization
1	Single-V butt weld 		
2			
3	Double V butt weld 		
4	Concave fillet weld 		

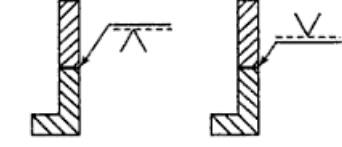
Table 3.3 Dimensions of Welds

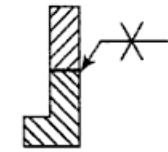
S. No.	Designation welds	Definition	Inscription	
1	Butt weld		S: minimum distance from the surface of the part to the bottom of the penetration, which cannot be greater than the thickness of the thinner part	∇
				s
				sY

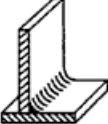
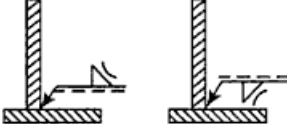
(Contd.)

Table 3.3 (Contd.)

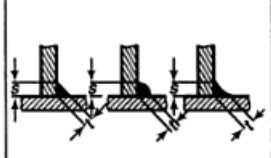
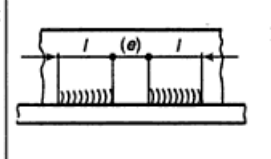
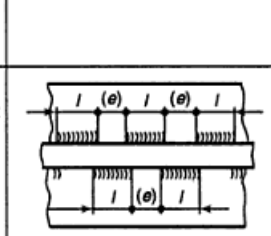
S. No.	Designation	Definition	Inscription
2	Continuous fillet weld		t : height of the largest isosceles triangle that can be inscribed in the section s : side of the largest isosceles triangle that can be inscribed in the section
3	Intermittent fillet weld		l : length of the weld (Without end craters). e : distance between adjacent weld elements. n : number of weld elements $\frac{t}{s}$ (Same as in 2)
4	Staggered intermittent fillet weld		l e } (Same as in 3) n t s } (Same as in 2)

3.4 WELDING PROCESS

Welding consists of joining two steel sections by establishing a metallurgical bond between them through the application of pressure and/or through fusion. The most commonly used process is arc welding—a fusion process. The bond between the metals is produced by reducing the surfaces to be joined to a molten state and then allowing the molten metal to solidify. When the molten metal solidifies, union is completed.

In the arc welding process (Fig. 3.4), the intense heat required to reduce the metal to liquid state is produced by an electric arc. The arc produces a temperature of about 3600 °C between the section to be welded and the electrode. The tremendous

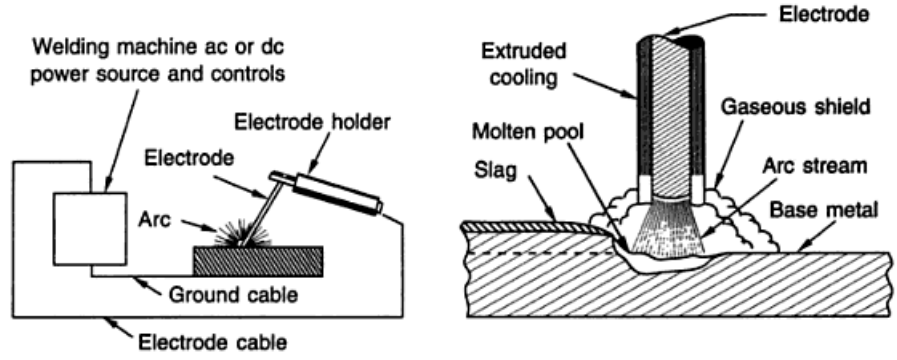

Fig. 3.4 Metal Arc Welding

heat at the tip of the electrode melts filler metal and base metal, thus liquifying them in a common pool called a *crater*. As the areas solidify, the metals are joined into one solid homogeneous piece. By moving the electrode along the joint to be welded, the surfaces to be jointed are welded together along their length. In all modern arc welding processes, the arc is shielded for the following reasons:

1. To protect the molten metal from air, either with gas vapour or slag.
2. To add alloying or fluxing ingredients
3. To control the melting of electrode for more effective use of the arc energy.

3.5 WELD DEFECTS

Good welding techniques, standard electrodes and proper joint preparation are the basic tools to achieve a sound weld. However, defects are inevitable and a knowledge of these is essential to minimise them. Some of the common defects in the welds are discussed below and are shown in Fig. 3.5.

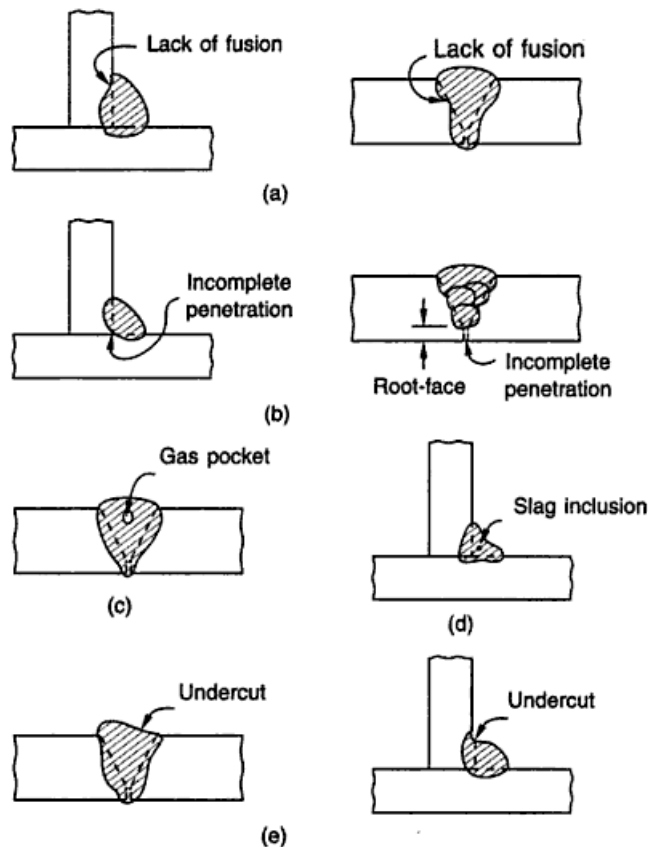

Fig. 3.5 Weld Defects

Incomplete Fusion is the failure of the base metal to get completely fused with the weld metal. It is caused by rapid welding and foreign materials on the surfaces to be welded.

Incomplete Penetration is the failure of the weld metal to penetrate the complete depth of joint. It is normally found with single vee and bevel joints and also because of large size electrodes.

Porosity occurs due to voids or gas pockets entrapped in the weld while cooling. It results in stress concentration and reduced ductility of the metal. Normally porosity is not a problem because each void is spherical and not a notch. Even with a slight loss in section because of the voids, their spherical shape may be considered to allow a smooth flow of stress around the void without any measurable loss in strength. Mainly these are caused because of careless use of back up plates, presence of moisture in the electrodes, hydrogen in the steel and excessive current.

Slag Inclusions are metallic oxides and other solid compounds which are sometimes found as elongated or globular inclusions. Being lighter than the molten material these float and rise to the weld surface from where these are removed after cooling of the weld. However, excessive rapid cooling of the weld may cause them to be trapped inside the weld. These present a problem in vertical and overhead welding.

Cracks are divided as hot and cold. Hot cracks occur due to the presence of sulphur, carbon, silicon and hydrogen in the weld metal. Phosphorous and hydrogen trapped in the hollow spaces of the metal structure give rise to the formation of cold cracks. Preheating of the metal to be welded eliminates the formation of cracks.

Undercutting is the local decrease of the thickness of the parent metal at the weld toe. This is caused by the use of excessive current or a very long arc.

3.6 PERMISSIBLE STRESSES

The permissible stresses in joining members of mild steel by welds conforming to I.S: 226–1975 and electrodes conforming to I.S: 814–2004 are given in Table 3.4. The stresses in M.K.S. units are recommended in I.S: 816–1969 (reaffirmed 1998) which is still not revised. The stress values are converted to SI units and presented in Table 3.4.

Table 3.4 Stress in Welds

S. No.	Type of Stress	Permissible Stress
1.	Tension or compression on section through throat of butt weld	150 N/mm ²
2.	Bending stress in tension or compression	165 N/mm ²
3.	Shear on section through throat of butt or fillet weld	108 N/mm ²
4.	Plug weld	108 N/mm ²

Notes

- (i) The permissible stresses in shear and tension are reduced to 80% when the welding is done in the field.
- (ii) When the effects of wind or earthquake are considered, the permissible stresses are increased by 25%.
- (iii) For combination of stresses clause 7.5.2 and 7.5.3 of I.S: 816–1969 (reaffirmed 1998) may be referred to.

3.7 DESIGN OF BUTT WELDS

A butt weld is shown in Fig. 3.6. A square butt weld is provided for sections less than 8 mm. Above this a single U, Vee or double U, Vee, etc. are provided. Butt weld is usually designed for direct tension or compression but if shear is also there then due provision should be made.

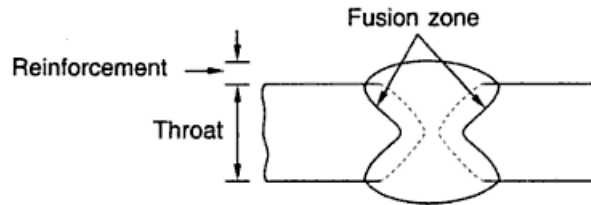

Fig. 3.6 Butt Weld

Since a butt weld involves no abrupt change in section at the joint, it is the most suitable form of the weld for transmitting alternating stresses.

Specifications

(i) **Reinforcement** Reinforcement is the extra weld metal which makes the throat dimension at least 10% greater than the thickness of the welded material. The reason for providing reinforcement is to increase the efficiency of the joint. The provision of reinforcement ensures that the depth through the weld is at least equal to the thickness of the plate and in case of thick plates, the metal within the thickness of the plate is in the annealed condition. However, any reinforcement on the weld is ignored in calculating the stresses. It is also difficult for a welder to make the weld flush with the parent metal; so extra metal is deposited.

Reinforcement makes the butt weld stronger for static loads. But in case of repeated and vibrating loads stress concentration develops in the reinforcement, leading to early failure. Hence, under such type of loads it is undesirable and the weld surface is made flush. Where a flush surface is required, the butt weld is first reinforced and then dressed flush. Subsequent removal of reinforcement is not considered as reducing the strength of the joint. In any case, the reinforcement should not exceed 3 mm.

(ii) **Size** The size of the butt weld used is specified by the throat dimension. This is also called effective throat thickness. In case of complete penetration of the butt weld the effective throat thickness is taken as the thickness of the thinner member jointed. In case the full penetration of butt weld cannot be achieved, an effective throat thickness of $7/8$ th of the thickness of the thinner member should be used. But for calculating the stress, the effective throat thickness is assumed to be $5/8$ th of thickness of the thinner member.

Except for the square edge type made in relatively thin metals, complete penetration welds generally are welded from both the sides. Incomplete penetration butt welds, usually are of the single V or single bevel type. In fact, incomplete penetration is the failure of the base metal and the weld metal to fuse at the root (Fig. 3.5(b)). This defect may be due to faulty design of the groove such as excessive

root-face dimension, root gap or groove angle, or it may be due to faulty technique such as the use of excessively large size electrodes, excessive speed or insufficient current. Incomplete penetration is particularly undesirable since it causes stress concentration under load and may cause shrinkage crack.

(iii) *Effective Area* The effective area of the butt weld is the product of effective throat thickness and the effective length of the butt weld. Effective length is the length of the weld for which the required size of the weld is done.

Design Procedure

1. In case of complete penetration of the butt weld, design calculations are not required as the weld strength at the joint is equal to the strength of the member connected.
2. In case of incomplete penetration of the butt weld, the effective throat thickness is computed and the required effective length is determined to furnish the strength equal to the strength of the members connected.

Let P = strength of the butt weld in Newtons
 σ_f = permissible stress in tension or compression in N/mm^2
 L = effective length of the weld
 t = effective throat thickness

$$\text{then} \quad P = Lt \sigma_f \quad (3.1)$$

3.8 DESIGN OF FILLET WELDS

The fillet weld is done for members which overlap each other. For such joints the critical stress is shear stress. They are also subjected to direct stresses but these are not of much importance. To all external appearances, the concave fillet weld seems to be larger than the convex weld. However, a check of the cross-section may show the concave weld to have less penetration and a smaller throat (Fig. 3.3) than first thought; therefore the convex fillet weld may actually be stronger even though it may have less deposited metal. Originally a concave fillet weld was favoured because it seemed to offer a smoother path for the flow of stress. But experience has shown that single pass fillet welds of this shape have a greater tendency to crack upon cooling, which outweighs the effect of improved stress distribution.

When a concave fillet weld cools and shrinks, its outer face is stressed in tension (Fig. 3.3), whereas a convex fillet weld on cooling shrinks and stresses the outer face in compression. Therefore in concave fillet welds cracks are developed on cooling. However, when concave welds are desired they are made in two or more passes—the first slightly convex, and the other passes are built up to form a concave fillet weld. Concave fillet welds are most suitable under alternating stresses.

Specifications

(i) *Size (s)* The size of a fillet weld is specified as the minimum leg length of the weld. The leg length is the distance from the root to the toe of the fillet weld (Fig. 3.7(a)). It is measured by the largest right angle triangle which can be inscribed within the weld (Fig. 3.7(a)). This definition would allow an unequal-legged fillet weld (Fig. 3.7(b)). Another definition stipulates the largest inscribed isosceles

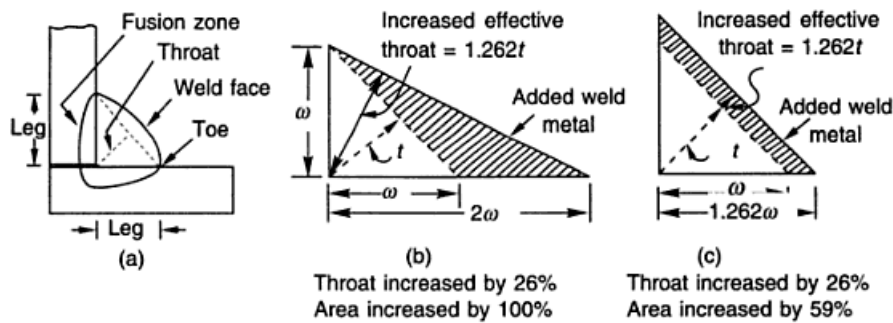

Fig. 3.7 Leg Length of Fillet Weld

right triangle and would limit this to an equal-legged fillet weld (Fig. 3.7(c)). Equal-legged fillet welds are preferred since they are easy to make. Unequal-legged fillet welds are sometimes used to get additional throat area, hence strength, when the vertical leg of the weld cannot be increased. An example of this is the attachment of a channel (shear connector) over a beam flange, shown in Fig. 3.8. Here the vertical leg of the fillet weld must be held to the thickness at the outer edge of the channel flange. Additional strength must be obtained by increasing the horizontal leg of the fillet. The weld size for unequal-legged fillet weld is specified by both leg lengths.

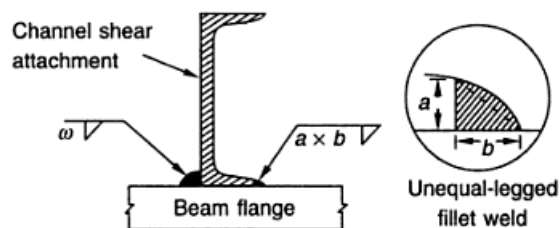

Fig. 3.8 Welding of Channel Shear Connector

The maximum size of a fillet weld is obtained by subtracting 1.5 mm from the thickness of the thinner member to be jointed. This specification limits the size of the fillet weld so that total strength may be developed without overstressing the adjacent metal.

A small weld placed on a thick member is undesirable. The heat generated in depositing the small size weld may not be appreciably enough to expand the base metal. Consequently, as the weld cools, it contracts and is prevented from doing so by the stable base metal. This results in initial stresses in the weld metal. Also the welding process will not heat the heavy plate much beyond the immediate vicinity of the weld. The mass of the thick plates will cool the weld too rapidly and tend to make it brittle. To help control this situation, I.S specifies the minimum size of a fillet weld as given in Table 3.5. The minimum size of the weld should not exceed the thickness of the thinner part jointed. In case of welds applied to the round toe of steel sections the maximum size of the weld should not exceed $3/4$ of the thickness of the section at the toe.

Usually a weld size closer to the minimum size is selected for the reasons stated as follows:

1. Large size welds require more than one run of welding which means that after the first run of welding chipping and cleaning will be required for proper bond of successive weld runs. This increases the cost.
2. A smaller size weld will be cheaper than a large one for the same strength considering the volume of welding. For example, a 300 mm, 5 mm size fillet weld will have the same strength (115.5 kN) as a 150 mm long and 10 mm size fillet weld. However the volume of weld metal for a 10 mm weld will be

$$\left[\frac{1}{2} \times 10^2 \times 150 = 7500 \text{ mm}^3 \right] \text{ which is about twice that of 5 mm size weld}$$

$$\left[\frac{1}{2} \times 5^2 \times 300 = 3750 \text{ mm}^3 \right].$$

Table 3.5 Minimum Size of Weld

Thickness of thicker member up to and including (mm)		Minimum size (mm)
over (mm)		
0	10	3
10	20	5
20	32	6
32	50	8 first run 10

(ii) **Effective Throat Thickness** is the shortest distance from the root of the fillet weld to the face of the diagrammatic weld (line joining the toes) as shown in Fig. 3.7(a). The effective throat thickness should not be less than 3 mm.

$$\text{Effective throat thickness} = K \times \text{size of weld} = KS$$

where S is the size of weld in mm and K is a constant. The value of K depends upon the angle between the fusion faces and is given in Table 3.6.

Table 3.6 Values of Constant K for Different Angles between Fusion Faces

Angle between fusion faces	60° – 90°	91° – 100°	101° – 106°	107° – 113°	114° – 120°
K	0.70	0.65	0.60	0.55	0.50

Note: Fillet weld is not recommended if the angle between fusion faces is less than 60° or more than 120°.

(iii) **Effective Length** is the length of the fillet weld for which the specified size and throat thickness of weld exist. It is taken equal to its overall length minus twice the weld size. The deduction is made to allow for craters to be formed at the ends of the welded length. End returns as shown in Fig. 3.9 are made equal to twice the size of the weld to relieve the weld length from high stress concentrations at their ends.

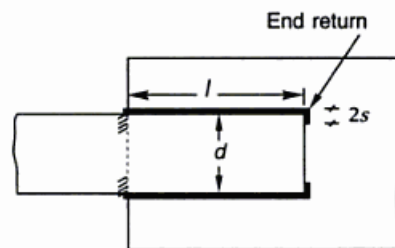

Fig. 3.9 End Returns

If the welds are parallel with the lines of stress, as in the case of longitudinal fillet welds, and are placed at the edges of the plates, there is a serious concentration of stress at the edges of the plate. Therefore, the length of the longitudinal (side) fillets on the flat should be not less than the width of the flat. The unevenness of the stress distribution is accentuated as the width of the plate increases. For this reason the perpendicular distance between longitudinal fillet welds is limited to 16 times thickness of the thinner plate jointed. If the plate is wider than this limit, slot or plug welds must be introduced. As a rule the provision of a slot tends to improve the distribution of stress in the plates as shown in Fig. 3.10. Longitudinal fillet welds in slots have the same strength as ordinary longitudinal fillet welds.

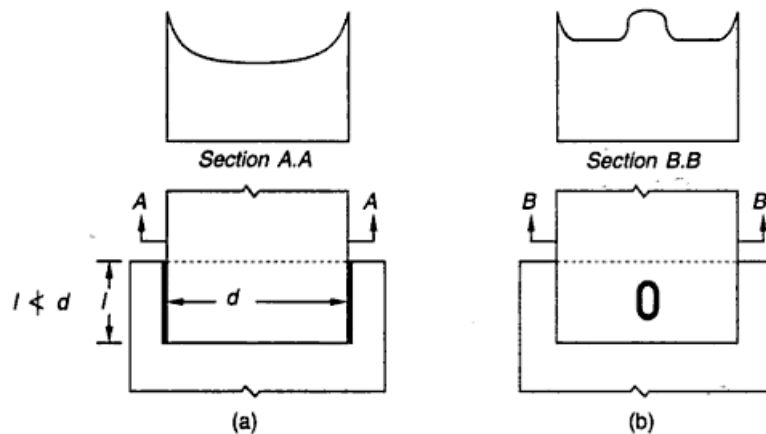

Fig. 3.10 Distribution of Stress in Side-Welded Tension Bar with and without Slot

Slots if provided should be set back behind the beginning of the welds on the edges of the plate to ensure that the effective area of plate is not reduced and that the deposition of slots does not lead to serious concentration of stress within the plates. On first sight the joint as shown in Fig. 3.11(b) might appear to be superior in strength to the one in Fig. 3.11(a), but it fails at smaller loads as shown in Fig. 3.11(c) owing to the stress concentration in the plate in the re-entrant angles of the notches.

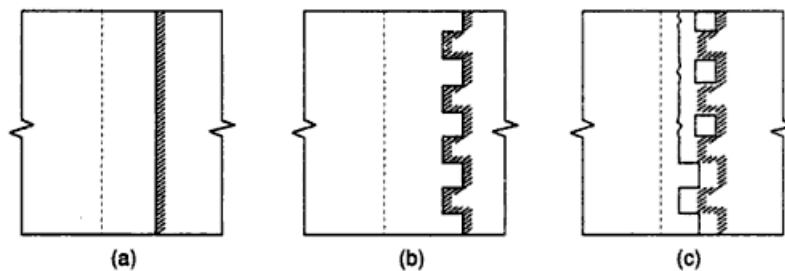

Fig. 3.11 Unsatisfactory Method of Increasing Length of Fillet Welds by Means of Square Slots

(iv) *Effective Area* The effective area of a fillet weld is equal to the effective length of the weld multiplied by the effective throat thickness.

(v) *Overlap* The overlap of plates to be fillet welded in a lap joint should not be less than 5 times the thickness of the thinner part.

(vi) *Transverse Spacing* between longitudinal fillet welds should not be more than $32t$ or 300 mm whichever is lesser.

Design

The following assumptions are made in the analysis of welded joints.

1. The welds connecting the various parts are homogeneous, isotropic and elastic elements.
2. The parts connected by the weld are rigid and their deformations are therefore, neglected.
3. Only stresses due to external loads are considered. Effects of residual stresses, stress concentrations and shape of the welds are neglected.

Design Procedure A fillet weld may be subjected to direct, bending and shear stresses but since the permissible stress in shear is always less, it controls the design.

1. The size (S) of the weld is assumed based on the thickness of the members to be jointed.
2. A fillet weld fails by shear at an angle of about 45° through the throat. Its strength is therefore assumed to equal the allowable shearing stress times the theoretical throat area of the weld. The strength of the weld is given by

$$P = Lt\tau_{vf}$$

$$\text{or} \quad P = LKS \tau_{vf} \quad (3.2)$$

where L = effective length of the weld in mm
 t = throat thickness in mm
 S = size of weld in mm
 τ_{vf} = shear stress in the weld in N/mm^2
 P = strength in newtons.

The strength of the weld/millimetre is calculated from Eq. (3.2).

3. Pull or thrust to be transmitted by the connections is estimated.
4. Effective length of the weld is calculated by dividing the pull or thrust by the strength of weld/mm. The length can either be adjusted as longitudinal fillet welds (parallel to the load axis) or as transverse fillet welds (perpendicular to the load axis) along with longitudinal fillet welds. It is a common practice to treat both the welds as if they are stressed equally.
5. If only a longitudinal fillet weld is made, a check is provided to see that the length of each longitudinal fillet weld is more than the perpendicular distance between them.
6. End returns of length twice the size of the weld are provided at each end of the longitudinal fillet weld.

Notes

1. It is assumed that the strength of the longitudinal and transverse fillet welds, as shown in Fig. 3.12, is same. Actually the strength of the transverse fillet weld is about 30%

more than the longitudinal fillet weld, because a transverse fillet weld is stressed more uniformly for full length whereas a longitudinal fillet weld is stressed non-uniformly due to varying deformations along the weld length. Another reason for the greater strength of the transverse fillet weld is given by tests which show that failure occurs at an angle other than 45° , giving transverse fillet welds a larger effective throat area.

- The main reasons for neglecting the greater strength of transverse fillet welds are probably an interest in simplifying design and the fact that in most cases little would be saved by differentiating between transverse and longitudinal welds. Many joints contain combinations of longitudinal, transverse, and oblique welds. Any attempt at a thorough analysis would become complicated and difficult to justify as a design measure.

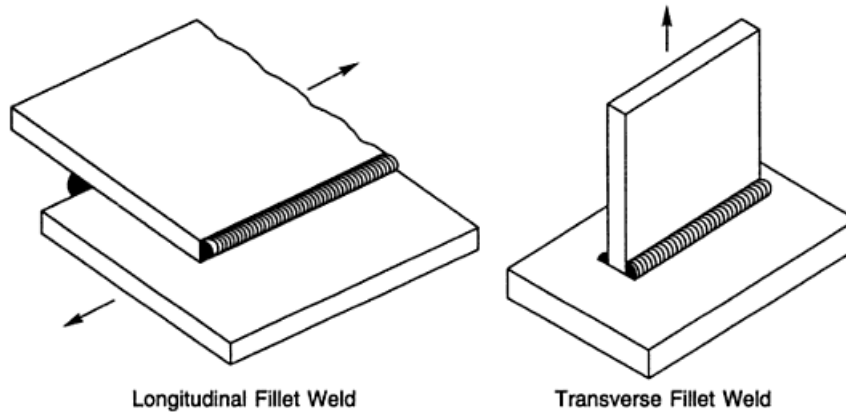

Fig. 3.12

3.9 DESIGN OF INTERMITTENT FILLET WELDS

Intermittent fillet welds are provided to transfer calculated stress across a joint when the strength required is less than that developed by a continuous fillet weld of the smallest practical size, e.g. in case of connections of stiffeners to the web of plate girders. The fillet weld length required is computed as a continuous fillet weld and a chain of intermittent fillet welds of total length equal to the computed length, with spacing as per I.S. specifications is provided, as shown in Fig. 3.13. Intermittent fillet welds as shown in Fig. 3.13(a) are structurally better than those shown in Fig. 3.13(b).

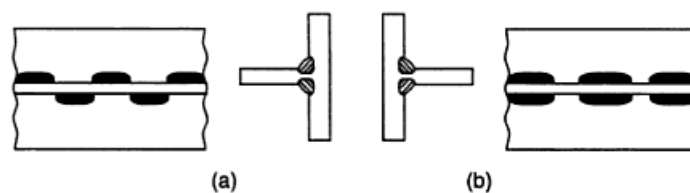

Fig. 3.13 *Intermittent Fillet Weld*

The question of whether and to what extent intermittent welds should be used involves consideration of the following points:

- Intermittent fillet welds are not economical unless the weld is of minimum size. A smaller fillet weld of a longer length is usually more economical for

the same strength. This is because the strength of a fillet weld increases directly with size but the weight of the weld metal increases with the square of the size.

2. If automatic welding is to be used the weld should be continuous.
3. If the structure is exposed, the use of continuous welds may be preferable as they are conducive to greater ease of maintenance and longer life of structure.
4. If severe dynamic loads act on the structure, intermittent welds must not be used.

Note Intermittent butt welds may be used to resist shear forces only and in general, are not recommended.

Design

1. The size of weld is assumed and the total effective length of the intermittent fillet weld required is computed.
2. Any intermittent fillet weld section should have a minimum effective length of four times the size of the weld with a minimum of 40 mm, except for plate girders (Clause 11.6 of I.S: 816–1969 (reaffirmed 1998)).
3. The clear spacing between an intermittent fillet weld should not exceed $12t$ for compression, and $16t$ for tension and should in no case be more than 200 mm.
4. At the ends, the longitudinal intermittent fillet weld should be of a length not less than the width of the member or else transverse welds should also be provided. If transverse welds are also provided along with longitudinal intermittent fillet welds, the total weld length at the ends should not be less than twice the width of the member.

3.10 FILLET WELDS FOR TRUSS MEMBERS

Truss members are composed of single angle or double angle sections. The following points should be borne in mind while designing the weld length:

1. The calculated weld length is placed as longitudinal fillet welds either on the two sides parallel to the axis of the load (Fig. 3.14(a)), or on three sides as shown in Fig. 3.14(b), i.e. transverse welds along with longitudinal welds. A longitudinal fillet weld length should never be placed on one side only as there will be a possibility of rotation.

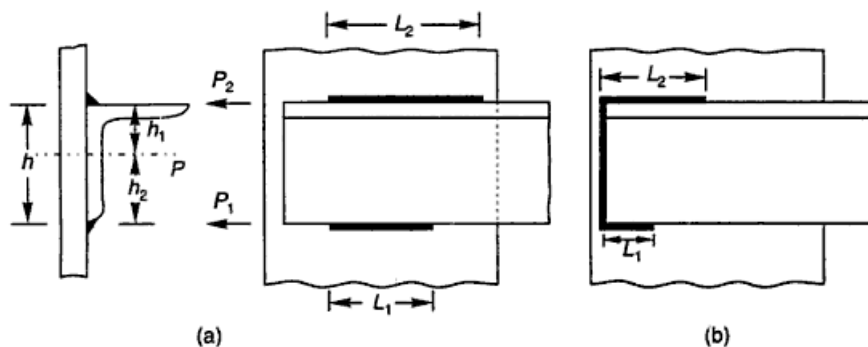

Fig. 3.14 Fillet Welds for Truss Member

2. The centre of gravity of the weld should coincide with the centroid of the section used as a truss member. If the member is symmetrical, the welds will be placed symmetrically but if the member is unsymmetrical (angle, channel) as is usually the case of a truss member, the lengths of longitudinal fillet welds are kept different on the two sides, as shown in Fig. 3.14(a), to achieve the above condition.

Let L_1, L_2 = length of longitudinal fillet welds on two sides
 P_1, P_2 = force along lengths L_1 and L_2 respectively
 P = force acting on the centroid of the section

Taking moment about the line passing through length L_1 (Fig. 3.14(a)),

$$P_2 h - Ph_2 = 0$$

or
$$P_2 = \frac{Ph_2}{h} \quad (3.3)$$

Similarly,

$$P_1 = \frac{Ph_1}{h} \quad (3.4)$$

Once the force P_1, P_2 are known the fillet weld lengths can be designed as described in Section 3.8.

The effectiveness of a fillet weld can be increased by connecting the two side welds by an end weld as shown in Fig. 3.14(b). When the weld length to be provided cannot be accommodated over the two parallel sides because of limited overlap, it may be the only choice. This arrangement also reduces the size of gusset plate and results in economy.

Let L_1, L_2 = length of longitudinal fillet welds
 h = length of end fillet weld
 P = force acting on the centroid of the section
 P_3 = force in the end fillet weld

Total length of weld required = $L_1 + L_2 + h$

Taking moment about the line passing through L_1 ,

$$P_2 h + P_3 \frac{h}{2} - Ph_2 = 0 \quad (3.5)$$

Taking moment about the line passing through L_2 ,

$$P_1 h + P_3 \frac{h}{2} - Ph_1 = 0 \quad (3.6)$$

Since P_3 ($0.7 hS \tau_{vf}$) is known, the above Eqs (3.5) and (3.6) can be solved for P_1 and P_2 . Once the forces P_1 and P_2 are known the fillet weld lengths L_1 and L_2 can be designed.

3.11 PLUG AND SLOT WELDS

Plug and slot welds are used most often to tie two parts together and, in particular to reduce the unsupported dimensions of cover plates in compression, which increases the critical stress. They may also be used for shear transmission. Their use is generally reserved for locations where it is impractical to make a fillet weld yet possible to provide a plug or slot. The critical section for either a plug weld or a slot weld is the faying surface between the connected parts. The unit shearing resistance

on this section is essentially the same as that of a fillet weld. Most specifications allow the same unit stress. Plug and slot welds should not be used to transmit tension, that is, a force normal to the faying surface. Tensile resistance depends largely upon the degree of penetration of the weld, which is apt to be rather than uncertain in either a plug or a slot weld.

Some engineers distrust plug and slot welds because of the difficulty of inspection. It is rather easy to make a plug or slot weld which appears excellent on the surface yet contains voids at the critical section.

The following specifications should be adhered to while designing plug and slot welds.

1. Width or diameter should be $\geq 3t$ and also ≥ 25 mm.
2. Corner radius in slotted hole should be $\geq 1.5t$ and also ≥ 12 mm.
3. Clear distance between holes should be $\geq 2t$ and also ≥ 25 mm where t is the thickness of plate having a hole or slot.

A combination of plug weld and other types of welds is permissible and the strength of the joint is the sum of the individual capacities of the welds.

3.12 FAILURE OF WELDS

Butt Welds When the butt weld is reinforced on both the sides of the plate, the section through the weld is increased to such an extent that it is unlikely for failure to occur in the weld, and the fracture normally occurs some distance away (Fig. 3.15(a)). The reinforcement acts as a supporting rib which inhibits necking in the immediate vicinity of the weld.

If the weld is ground flush with the surface of the plate, the position of the fracture depends upon the relative strength of the plate and weld metal. If the tensile strength or the yield point is lower for the weld metal than for the

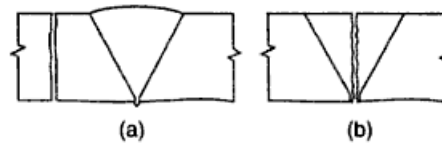

Fig. 3.15 Failure of Butt Welds

plate, failure takes place through the centre of the weld (Fig. 3.15(b)). But if the tensile strength and yield point of the weld metal are higher, failure takes place in the plate away from the weld. Failure in the weld junction is quite unusual.

Under conditions of free bending across a reinforced butt weld, the stiffening effect of the reinforcement inhibits failure at the joint. But since stress concentration occurs at the weld junction, due to change of the section, there is some tendency for a crack to start at the weld junction itself with a flush butt weld, failure under such a condition occurs in the middle of the weld. If there is a wide difference in the tensile strength or yield point between the two metals, the failure may occur at the junction.

End Fillet Weld The plane of the fracture in a normal profile convex end fillet weld (Fig. 3.16(a)) is along the diagonal from the root of the fillet (Fig. 3.16(b)). When the fillet is subjected to shear in addition to the tensile stress, the position of the line of fracture departs from the diagonal according to the relative magnitude of the two stresses (Fig. 3.16(c)). If the fillet legs are unequal, a fracture usually occurs near the shorter leg (Fig. 3.16(d)). If the tensile strength of the weld metal is considerably greater than that of the plate, the fillet may remain intact and be pulled right out of the plate (Fig. 3.16(e)). With all end fillet welds failures occur abruptly, after a small amount of deformation.

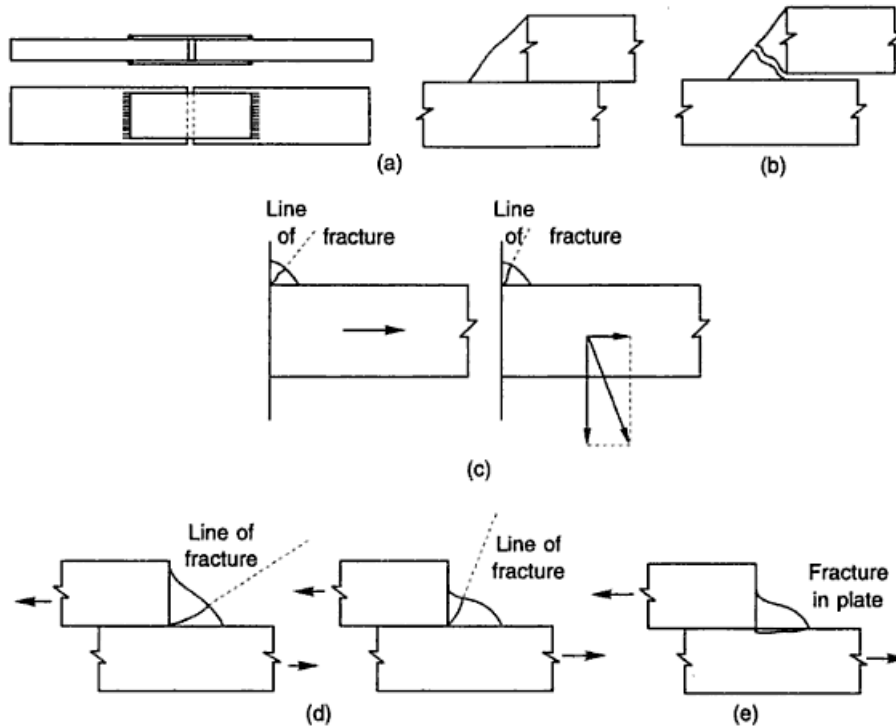

Fig. 3.16 Position of Fracture in End Fillet Welds

Side Fillet Weld In a side convex fillet weld subjected to shear stress along the weld, failure occurs down the throat of the weld. The break commences at the toe of the fillet at one or both the ends of the weld and as it progresses, the plane of fracture rotates (Fig. 3.17). The failure is gradual and considerable deformation of the fillet and usually also of the plates takes place before the final fracture.

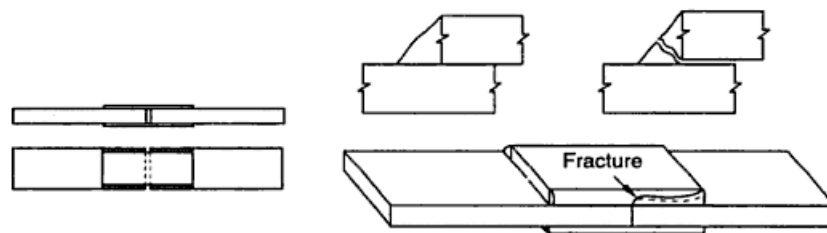

Fig. 3.17 Position of Fracture in Side Fillet Welds

3.13 DISTORTION OF WELDED PARTS

Fillet Weld Consider a fillet weld as shown in Fig. 3.18(a). After the weld is cooled, shrinkage is greatest along the face of the weld where large portion of filler metal is deposited. If the vertical plate is free to move (Fig. 3.18(b)), it is pulled over by the shrinkage of the weld without residual stresses due to shrinkage. This is

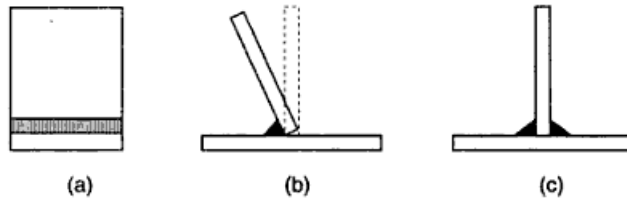

Fig. 3.18 Distortion and Residual Stresses of Fillet Welds

so because no resistance is offered to such distortion. Now a fillet weld on other side of the vertical plate (Fig. 3.18(c)), if deposited, will tend to pull the plate back into the original position generating large residual stress in both the welds. This residual stress generated because of asymmetry of welding sequence can be minimized by depositing the two welds simultaneously.

Short-length Butt Weld Consider a butt weld connecting two plates A and A_1 as shown in Fig. 3.19. When molten metal is deposited part A and zone B of plate A_1 are heated rapidly to a very high temperature allowing the steel to behave plastically. Zone C being heated less than the remaining two is assumed to behave elastically. The heated portions tend to expand in proportion to the change in temperature. Zone C , being less heated, tends to expand less and restrains some of expansion of zone B and part A . The distorted shape is shown in Fig. 3.19(b). Since part A and zone B are restrained from expanding while in a plastic state, in cooling they tend to shrink to a length less than their original dimension. Zone C , which did not undergo plastic deformation, tends to shrink to its original dimension and thus will restrain part A and zone B from free shrinkage. When the plates are completely cooled, part A will be shorter than its original length and will present a distorted shape shown in Fig. 3.19(c). Since part A and zone B have been prevented from full shrinkage, they are subjected to tension, whereas zone C is subjected to compression and bending, resulting in essentially compressive stresses at the boundary between zones B and C , and tensile stresses at the free edge of zone C . If the two plates shown in Fig. 3.19 were symmetrical about the weld, the distortions and residual stresses would be reduced considerably.

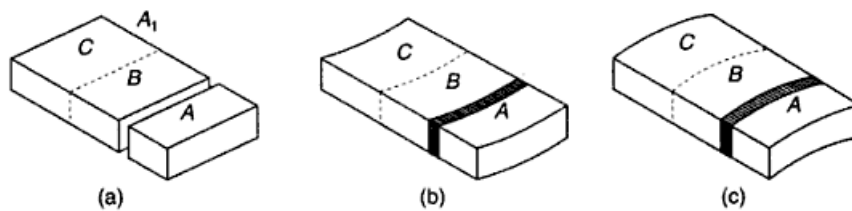

Fig. 3.19 Distortion and Residual Stresses in Butt Weld

Long Butt Weld Consider a long butt weld as shown in Fig. 3.20. One part of the plate zone D , is in a heated or expanding state similar to Fig. 3.19(b) while the zone

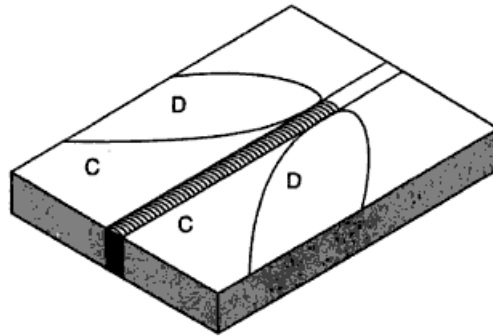

Fig. 3.20 Heating and Cooling of a Long Butt Weld

C is in a cooling or contracting state similar to Fig. 3.18(c). The relative areas of two zones, final distortions, and the residual stresses depend on speed of welding and on arrangement and sequence of welds designed to minimize distortions and residual stresses. There are a number of techniques to minimize residual stresses and prevent distortions. Some of which are preheating the parts before welding, hammering the weld to elongate it locally and to relieve the shrinkage forces (peening), etc.

3.14 INSPECTION OF WELDS

A poor weld leads to collapse; therefore proper inspection of the weld is necessary. Some of the methods for inspecting welds are as follows:

(i) *Magnetic Particle Method* Iron fillings are spread over the weld and it is then subjected to an electric current. The fillings form patterns which are interpreted to locate surface cracks.

(ii) *Dye Penetration Method* The depth of a crack can be estimated by this method. A dye is applied over the weld surface and then the surplus is removed. A dye absorber is placed over the weld which oozes the dye giving an idea of the depth of the crack.

(iii) *Ultrasonic Method* In this method, ultrasonic sound waves are sent through the weld. Defects like flaws, blow holes, etc. affect the time interval of sound transmission identifying the defect.

(iv) *Radiography* X-rays or gamma rays are used to locate defects. This method is used in butt welds only. It cannot be used in fillet welds because the parent material will also form part of the projected picture.

3.15 FILLET WELD VS. BUTT WELD

Fillet weld are preferred in comparison to butt welds due to the following reasons:

1. A fillet weld saves the operation of veeing and finishing the ends of members.
2. In case of a butt weld, members are fabricated slightly long and cut exactly to have a close fit in the field. This process is uneconomical.
3. Butt welds have higher residual stresses.

3.16 WELDED JOINTS VS. RIVETED JOINTS

1. Welded joints are economical. This is because splice plates and rivet materials are eliminated. Also, the gusset plates required are of a smaller size because of the reduced connection length. Labour cost is also less as only one person is required to do the welding whereas at least four persons are required for riveting.
2. Welded structures are more rigid (due to the continuity of the section at the joint) as compared to riveted joints. In riveted joints, cover plates, connecting angles, etc. deflect along with the member during load transfer and make the joint more flexible.
3. Due to the fact that the strength of a welded joint is the same as that of the parent metals, even a smallest piece of the metal which otherwise is a scrap can be used, bringing overall economy.
4. With welding it has become possible to connect tubular sections, which are structurally very economical.
5. Due to the fusion of two metal pieces jointed, a continuous structure is obtained, which gives a better architectural appearance than riveted joints.
6. Alterations can be done with less expenses in case of welding as compared to riveting.
7. The process of welding is quicker in comparison to riveting.
8. The process of welding is silent, whereas in the case of riveting a lot of noise is produced.
9. In welding less safety precautions are required for the public in the vicinity, whereas a hot rivet may toss and injure the persons working.
10. As splice plates, rivets, etc. are not used, the details and drawings of welded structures are easier and less time consuming.
11. The efficiency of a welded joint is more than that of a riveted joint. In fact a proper welded joint may have 100% efficiency.
12. Members to be jointed may distort due to the heat during the welding process, whereas there is no such possibility in riveted joints.
13. The possibility of a brittle fracture is more in the case of welded joints as compared to riveted joints.
14. The inspection of welded joints is difficult and expensive, whereas riveted joints can be inspected simply by tapping the joint with a hammer.
15. A more skilled person is required to make a welded joint as compared to the riveted joint.

3.17 SELECTION OF FASTENERS

After being conversant with various types of fasteners, a designer may choose a particular type based on the following considerations:

(i) Nature of the Connections First, it should be ascertained whether the connection is for a permanent structure or for a temporary one. For permanent structure rivets, welds and high strength bolts are recommended, whereas for temporary structures ordinary bolts and pins may be used.

(ii) **Strength and Efficiency Required** For high strength and efficiency, welding and HSFG bolts are preferred.

(iii) **Availability of Skilled Persons** If the joint is a welded or with HSFG bolts, highly skilled people are required, whereas riveting, bolting or pin connections can be made by ordinary technicians.

(iv) **Cost** The cost of connection influences the overall cost of the structure, e.g., if the connections are to be made in the field, riveted or high strength bolted connections may be economical as compared to welded joints. Also, welding at the site may not be feasible due to lack of power supply. Some of the other factors which should be given due consideration are loading conditions, equipments available and skilled fabricators.

Unfinished bolts, being economical, can be provided for structures subjected to small static loads and temporary structures. The bolting process is rapid and less skilled labour can be employed. High strength friction bolts are costly but are good for fatigue loads. Welding has the biggest advantage of giving rigid (fully moment-resisting) joints. Also, it gives a better appearance and uses metal economically. Rivets are becoming obsolete due to their limitations as discussed earlier. These are preferred only when a simple connection with a small moment-resistance is desired. Normally it has been found economical to use riveted or welded connections in the shop and bolted connections in the field.

Solved Examples

Example 3.1 Two plates of thickness 16 mm and 14 mm are to be joined by a butt weld, as shown in Fig. Ex. 3.1. The joint is subjected to a tensile force of 280 kN. Due to some reasons the effective length of the weld that could be provided was 175 mm only. Check the safety of the joint if:

1. Single-V butt weld is provided,
2. Double-V butt weld is provided.

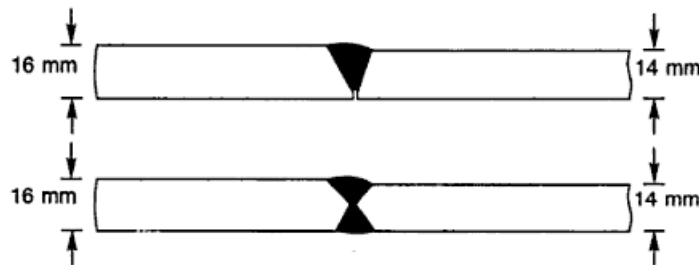

Fig. Ex. 3.1

Solution The allowable stress in butt weld in tension is 150 N/mm^2 .

Single-V butt weld In case of single-V butt weld, incomplete penetration of the weld takes place; therefore as per I.S. specifications,

$$\begin{aligned}\text{Throat thickness} &= \frac{5}{8} t \\ &= \frac{5}{8} \times 14 = 8.75 \text{ mm}\end{aligned}$$

Effective length of the weld = 175 mm

$$\begin{aligned}\text{Strength of weld} &= 8.75 \times 175 \times 150 \times 10^{-3} \\ &= 229.68 \text{ kN} < 280 \text{ kN}\end{aligned}$$

which is inadequate.

Double-V butt weld Complete penetration of the butt weld takes place in case of a double-V butt weld. Therefore, as per I.S. specification

$$\begin{aligned}\text{Throat thickness} &= \text{thickness of thinner plate} \\ &= 14 \text{ mm}\end{aligned}$$

$$\begin{aligned}\text{Strength of weld} &= 14 \times 175 \times 150 \times 10^{-3} \\ &= 367.50 \text{ kN} > 280 \text{ kN}\end{aligned}$$

which is adequate and safe.

Example 3.2 A butt weld is used to connect two plates 180 mm × 18 mm each. Find out the stress developed in the weld if it is subjected to a moment of 13000 kN mm.

Solution Assume the butt weld to be double-U type.

$$\text{The section modulus of the butt weld} = \frac{18 \times 180^2}{6} = 97.2 \times 10^3 \text{ mm}^3$$

$$\text{Permissible bending stress, } \sigma_{bf} = 165 \text{ N/mm}^2$$

$$\begin{aligned}\sigma_{bf, \text{ cal}} &= \frac{13000 \times 10^3}{97.2 \times 10^3} \\ &= 133.74 \text{ N/mm}^2 < 165 \text{ N/mm}^2\end{aligned}$$

which is safe.

Example 3.3 A tie member in a truss girder is 250 mm × 14 mm in size. It is welded to a gusset plate 10 mm thick by a fillet weld. The overlap of the member is 300 mm. The weld is 6 mm in size. Find the strength of the joint if the welding is done as shown in Fig. Ex. 3.3. What is the increase in strength if welding is done all around.

Allowable shear stress in weld = 108 N/mm².

Solution Effective length of weld

$$\begin{aligned}&= 2 \times 300 + 250 \\ &= 850 \text{ mm}\end{aligned}$$

Effective throat thickness = 0.7 × 6 = 4.2 mm

$$\begin{aligned}\text{Strength of the fillet weld} &= 850 \times 4.2 \times 108 \times 10^{-3} \\ &= 385.56 \text{ kN}\end{aligned}$$

When the welding is done all around,

$$\begin{aligned}\text{Effective length of weld} &= 2 \times 300 + 2 \times 250 \\ &= 1100 \text{ mm}\end{aligned}$$

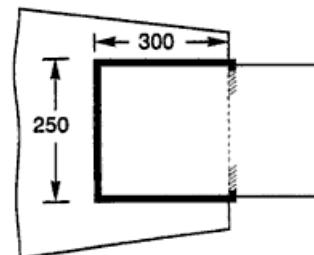

Fig. Ex. 3.3

Strength of the fillet weld = $1100 \times 4.2 \times 108 \times 10^{-3} = 498.96 \text{ kN}$
 The strength of the weld is increased by
 $498.96 - 385.56 = 113.4 \text{ kN}$

Example 3.4 A tie member $75 \text{ mm} \times 8 \text{ mm}$ is to transmit a load of 90 kN . Design the fillet weld and calculate the necessary overlap.

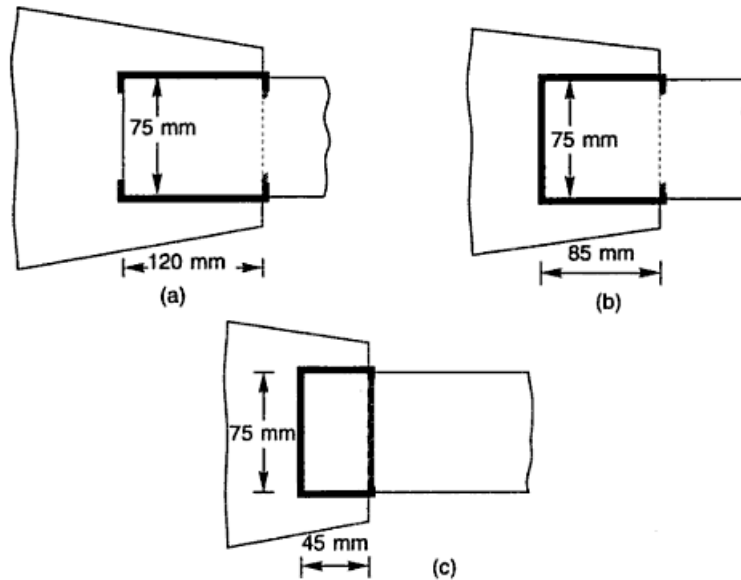

Fig. Ex. 3.4

Solution The tie member can be welded to the gusset plate on two sides parallel to the load axis, or on three sides or on all the four sides. The economy lies in finding out the minimum overlap, keeping in mind the specifications laid down by the I.S. code.

$$\begin{aligned} \text{Strength of weld} &= \text{load over the joint} \\ &= 90 \text{ kN} = 90 \times 10^3 \text{ N} \end{aligned}$$

Size of weld

Minimum size of weld for 8 mm thick section = 3 mm

Maximum size of weld = $8 - 1.5 = 6.5 \text{ mm}$

Provide a size of weld between 3 mm and 6.5 mm .

Let

$$S = 5 \text{ mm}$$

$$\text{Effective throat thickness} = 0.7 \times 5 = 3.5 \text{ mm}$$

(a) *Welds on two sides*

Effective length of the weld

$$\begin{aligned} &= \frac{\text{strength}}{\text{effective throat thickness} \times \text{allowable stress}} \\ &= \frac{90 \times 10^3}{3.5 \times 108} = 238.09 \approx 240 \text{ mm} \end{aligned}$$

$$\text{Length of weld to be provided on each side} = \frac{240}{2} = 120 \text{ mm} < 75 \text{ mm}$$

Therefore, provide 120 mm long and 5 mm size fillet welds on the two sides, as shown in Fig. Ex. 3.4(a).

The necessary overlap required is 120 mm. The welds are turned at the ends.

$$\text{Overall length of weld required} = 2(120 + 2 \times 5) = 260 \text{ mm}$$

(b) *Welds on three sides* Length of the weld required is 240 mm. The overlap required can be found by the following relation:

$$240 = 2 \times \text{overlap} + 75$$

or

$$\text{Overlap} = 82.5 \text{ mm} \approx 85 \text{ mm}$$

Provide an overlap of 85 mm as shown in Fig. Ex. 3.4(b).

(c) *Welds on all the four sides* Length of the weld required is 240 mm. The overlap required can be found by the following relation:

$$240 = 2 \times \text{overlap} + 2 \times 75$$

or

$$\text{Overlap} = 45 \text{ mm}$$

Provide an overlap of 45 mm, as shown in Fig. Ex. 3.4(c).

Therefore, it is found that the most economical way to join the member is by welding on all four sides.

Example 3.5 A circular plate, 150 mm in diameter, is welded to another plate by means of a 6 mm fillet weld as shown in Fig. Ex. 3.5. Calculate the greatest twisting moment that can be resisted by the weld.

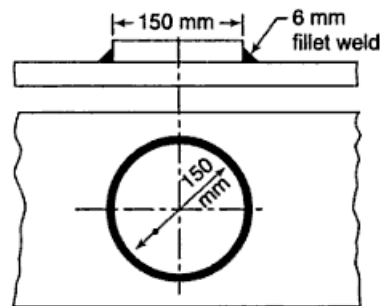

Fig. Ex. 3.5

Solution Safe load that can be resisted per mm length of weld
 $= 0.7 \times 6 \times 108$

$$= 453.6 \text{ N/mm}$$

$$\text{Length of the weld} = \pi d = \pi \times 150 = 471 \text{ mm}$$

$$\text{Greatest twisting moment} = 452.6 \times 471 \times$$

$$\frac{150}{2} \times 10^{-6} = 16.02 \text{ kNm}$$

Example 3.6 A circular penstock of mild steel, 1.2 m in diameter, is fabricated with a 12 mm plate and secured by fillet welds of 8 mm size, provided on the inside and outside of the lapped ends as shown in Fig. Ex. 3.6. Determine the safe internal pressure that can be allowed in the penstock.

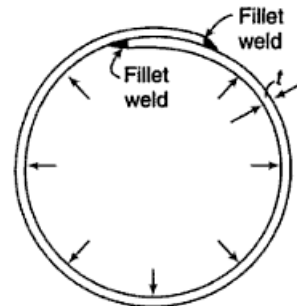

Fig. Ex. 3.6

Solution Throat thickness, $t = 0.7 \times 8 = 5.60 \text{ mm}$
 Internal force per unit length, causing bursting of

$$\text{pipe} = \frac{pd}{2}$$

where p is the internal pressure and d the diameter of penstock.

Resistance offered by the weld, per unit length = $2t\tau_{vf}$

$$\text{Hence } \frac{pd}{2} = 2t\tau_{vf}$$

$$\text{or } p = \frac{4t\tau_{vf}}{d} = \frac{4 \times 5.6 \times 108}{1200} = 2.016 \text{ N/mm}^2$$

Example 3.7 A tie member consisting of angle section I.S.A 80 mm × 50 mm × 8 mm ($f_y = 250$ MPa) is welded to a 12 mm gusset plate. Design welds to transmit a load equal to the full strength of the member. Refer Fig. Ex. 3.7.

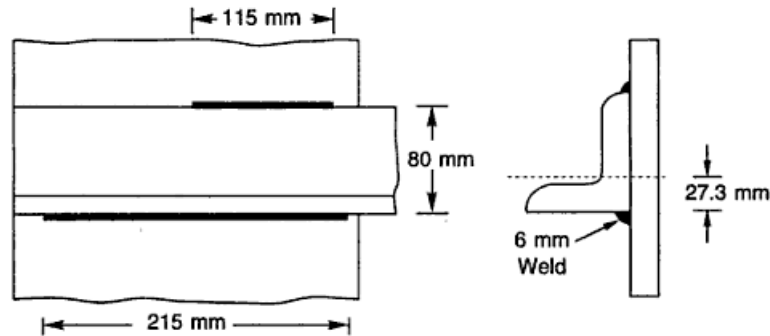

Fig. Ex. 3.7

Solution Let P be the strength of the member.

From I.S. Handbook No. 1, the relevant properties of the angle section are,

$$A = 978 \text{ mm}^2,$$

$$C_{xx} = 27.3 \text{ mm}$$

$$\sigma_{at} = 0.6f_y = 0.6 \times 250 = 150 \text{ N/mm}^2$$

$$P = \text{cross-sectional area} \times \text{permissible stress} \\ = 978 \times 150 \times 10^{-3} = 146.700 \text{ kN}$$

The weld will be designed to transmit a force equal to 146.7 kN.

The force resisted by the weld at the lower side of angle,

$$P_1 = \frac{146.7 \times (80 - 27.3)}{80} = 96.638 \text{ kN}$$

The force resisted by the weld at the upper side of angle,

$$P_2 = \frac{146.7 \times 27.3}{80} = 50.061 \text{ kN}$$

Let us assume the size of weld, $S = 6$ mm (> 3 mm)

$$\text{Effective throat thickness of weld} = 0.7 \times 6 = 4.2 \text{ mm}$$

$$l_1 = \frac{96.638 \times 10^3}{4.2 \times 108} = 213.04 \approx 215 \text{ mm}$$

$$l_2 = \frac{50.061 \times 10^3}{4.2 \times 108} = 110.36 \text{ mm} \approx 115 \text{ mm}$$

Example 3.8 Design the joint in Example 3.7 if the weld is to be done on the three sides as shown in Fig. Ex. 3.7.

Solution Total length of weld = $l_1 + l_2 + 80$

$$\text{Strength of weld/mm length} = 4.2 \times 108 = 453.6 \text{ N}$$

Equating the strength of the total weld to the load,

$$(l_1 + l_2 + 80) \times 453.6 = 146.7 \times 10^3$$

$$l_1 + l_2 = 243.41 \text{ mm}$$

Take moment about top edge of angle section,

$$453.6 \times 80 \times \frac{80}{2} + 453.6 \times l_1 \times 80 = 146.7 \times 10^3 (80 - 27.3)$$

$$l_1 = 173.04 \text{ mm} \approx 175 \text{ mm}$$

Hence,

$$l_2 = 243.41 - 173.04$$

$$= 70.37 \text{ mm} \approx 75 \text{ mm}$$

Example 3.9 A tie member of a truss consists of double angle section of dimensions 80 mm × 80 mm welded on the opposite side of a 12 mm thick gusset plate. Design a fillet weld to make the joint. Axial tension in the member is 200 kN.

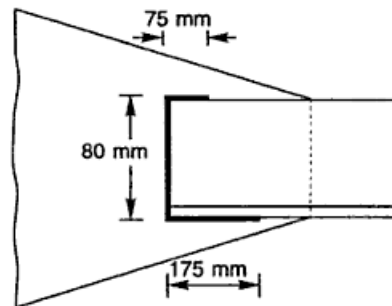

Fig. Ex. 3.8

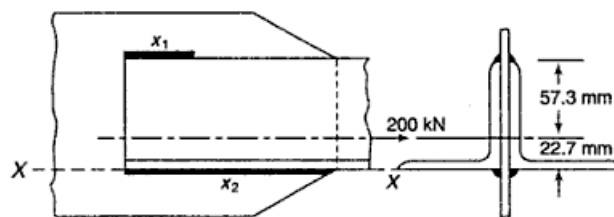

Fig. Ex. 3.9

Solution Refer Fig. Ex. 3.9.

Let the lengths of weld at top and bottom edges be x_1 and x_2 , respectively for each angle.

$$\text{Total length of weld} = 2(x_1 + x_2) \text{ mm}$$

$$\text{Maximum size of weld} = 8 - 1.5 = 6.5 \text{ mm}$$

$$\text{Minimum size of weld} = 5 \text{ mm}$$

Let us provide 5 mm weld size.

$$\text{Strength of weld per mm length} = 0.7 \times 5 \times 108 = 378 \text{ N/mm}$$

Equating the strength of the weld to the tension in the member,

$$378 \times 2(x_1 + x_2) = 200 \times 10^3$$

$$(x_1 + x_2) = 264.55 \text{ mm}$$

Taking moment about X-X

$$378 \times 2x_1 \times 80 = 200 \times 10^3 \times 22.7$$

$$x_1 = 75 \text{ mm}$$

$$x_2 = 264.55 - 75 = 189.55 \approx 190 \text{ mm}$$

Provide

$$x_1 = 75 \text{ mm} \quad \text{and} \quad x_2 = 190 \text{ mm}$$

Example 3.10 An I.S.L.C. 300 @ 324.7 N/m is used to transmit a force of 600 kN. The channel section is connected to a gusset plate 10 mm thick. Design a fillet weld if the overlap is limited to 350 mm. Use slot welds if required.

Solution Relevant properties of I.S.L.C. 300 @ 324.7 N/m are,

$$A = 4211 \text{ mm}^2$$

$$T = 11.6 \text{ mm}$$

$$t = 6.7 \text{ mm}$$

The maximum size of weld = $6.7 - 1.5 = 5.2 \text{ mm}$

Provide 5 mm-size weld.

$$\text{Throat thickness} = 0.7 \times 5 = 3.5 \text{ mm}$$

$$\text{Strength of weld/mm length} = 3.5 \times 108 = 378 \text{ N}$$

$$\text{Length of weld required} = \frac{600 \times 1000}{378} = 1587.30 \approx 1590 \text{ mm}$$

The maximum length of the weld that can be provided is

$$300 + 2 \times 350 = 1000 \text{ mm} (< 1590 \text{ mm}).$$

Hence, the length of the weld will be provided with slot welds.

Provide width of slots 25 mm ($3t = 3 \times 6.7 = 20.1 \text{ mm}$ or 25 mm whichever is greater).

Let length of the slot be x ,

$$1590 = 2 \times 350 + 300 + 4x$$

$$x = 147.5 \text{ mm} \approx 150 \text{ mm}$$

Provide 150 mm long fillet welds in slots as shown in Fig. Ex. 3.10.

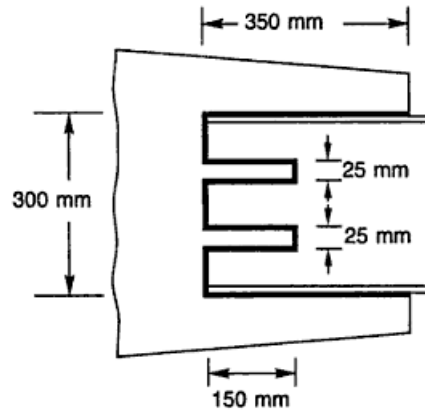

Fig. Ex. 3.10

Example 3.11 Design a suitable fillet weld to connect the web plate to the flange plate and the flange plate to the cover plate of the compression flange of a plate girder as shown in Fig. Ex. 3.11. The web plate is $1000 \text{ mm} \times 12 \text{ mm}$. The flange plate and cover plate are $400 \text{ mm} \times 20 \text{ mm}$ and $375 \text{ mm} \times 16 \text{ mm}$ respectively. The maximum bending moment $M = 500 \times 10^3 \text{ kN mm}$ and maximum shear force is $V = 1000 \text{ kN}$.

Solution Connection of web and flange plate

Minimum size of weld = 5 mm

Maximum size of weld = $12 - 1.5 = 10.5 \text{ mm}$

Adopt 7 mm size of fillet weld.

$$\tau_{vf, \text{cal}} = \frac{V \bar{A} \bar{Y}}{I_{XX} \Sigma t}$$

$$t = 0.7 \times S = 0.7 \times 7 = 4.9 \text{ mm}$$

$$\Sigma t = 2 \times 4.9 = 9.8 \text{ mm}$$

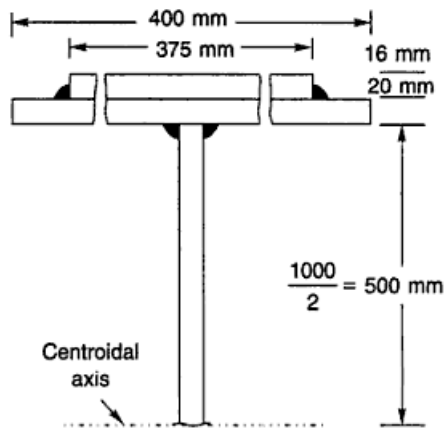

Fig. Ex. 3.11

$$\begin{aligned} A\bar{Y} &= 400 \times 20 \times (500 + 10) + 375 \times 16 \times (500 + 20 + 8) \\ &= 408 \times 10^4 + 316.8 \times 10^4 = 724.8 \times 10^4 \text{ mm}^3 \end{aligned}$$

$$\begin{aligned} I_{XX} &= 2 \times \left[\frac{375 \times 16^3}{12} + 375 \times 16 \times 528^2 \right. \\ &\quad \left. + \frac{400 \times 20^3}{12} + 400 \times 20 \times 510^2 \right] + \frac{12 \times 1000^3}{12} \\ &= 8.507 \times 10^9 \text{ mm}^4 \end{aligned}$$

$$\begin{aligned} \tau_{vf, \text{cal}} &= \frac{1000 \times 10^3 \times 724.8 \times 10^4}{8.507 \times 10^9 \times 9.8} \\ &= 86.93 \text{ N/mm}^2 < 108 \text{ N/mm}^2 \end{aligned}$$

which is all right.

Connection of flange plate to cover plate

Adopt 6 mm size of fillet weld.

$$S = 6 \text{ mm}$$

$$t = 0.7 \times 6 = 4.2 \text{ mm}$$

$$\Sigma t = 2 \times 4.2 = 8.4 \text{ mm}$$

$$\bar{AY} = 375 \times 16 \times (500 + 20 + 8) = 316.8 \times 10^4 \text{ mm}^3$$

$$\begin{aligned} \tau_{vf, \text{cal}} &= \frac{1000 \times 10^3 \times 316.8 \times 10^4}{8.507 \times 10^9 \times 8.4} \\ &= 44.33 \text{ N/mm}^2 < 108 \text{ N/mm}^2 \end{aligned}$$

which is as should be.

Example 3.12 A 120 mm diameter and 6 mm thick pipe is welded to a 14 mm plate by fillet weld. The pipe is subjected to a vertical load of 3 kN at 1.00 m from the welded end and a twisting moment of 1.2 kNm. Design the joint.

Solution Direct load = 3 kN = 3×10^3 N

$$\text{Bending moment} = 3 \times 10^3 \times 1000 = 3 \times 10^6 \text{ Nmm}$$

$$\text{Twisting moment} = 1200 \times 10^3 \text{ Nmm}$$

Let t = Effective throat thickness of the weld.

$$\text{Polar moment of inertia, } I_{zz} = 2\pi r^3 t$$

$$= 2\pi \times 60^3 \times t = 1357168 t \text{ mm}^4$$

$$I_{xx} = \frac{I_{zz}}{2}$$

$$= \frac{1357168 t}{2} = 678584.01 t \text{ mm}^4$$

$$\text{Shear stress due to direct load} = \frac{3 \times 10^3}{2\pi \times 60 \times t} = \frac{7.957}{t} \text{ N/mm}^2$$

$$\text{Bending stress due to bending moment} = \frac{3 \times 10^6 \times 60}{67.85 \times 10^4 \times t} = \frac{265.29}{t} \text{ N/mm}^2$$

This bending stress shall be treated as shear since, the actual failure will be along the throat of the weld.

$$\text{Shear stress due to twisting moment} = \frac{1200 \times 10^3 \times 60}{135.7168 \times 10^4 \times t} = \frac{53.05}{t} \text{ N/mm}^2$$

$$\text{Combined stress} = \left\{ \left(\frac{7.957}{t} \right)^2 + \left(\frac{265.29}{t} \right)^2 + \left(\frac{53.05}{t} \right)^2 \right\}^{1/2}$$

$$\text{or } \frac{270.65}{t} = 108$$

$$t = \frac{270.65}{108} = 2.50 \text{ mm} \approx 3 \text{ mm}$$

Hence, provide a 3 mm fillet weld.

Exercises

3.1 Find out the strength of a 6 mm fillet weld per mm length.

A 200 mm wide plate is to be jointed to another plate section 300 mm wide. Find out the strength of the joint if the overlap of the plates is 150 mm. Both longitudinal and end fillet welds are provided. What will be the overlap required if only longitudinal fillet welds are provided? The plates are 8 mm thick.

- 3.2 Two plates 12 mm thick are joined by (i) a single V-butt weld (ii) a double V-butt weld. The effective length of the weld is 220 mm. Determine the strength of the welded joints.
- 3.3 Determine the maximum load which can be applied to the fillet welds for the cases shown in Fig. Prob. 3.3.

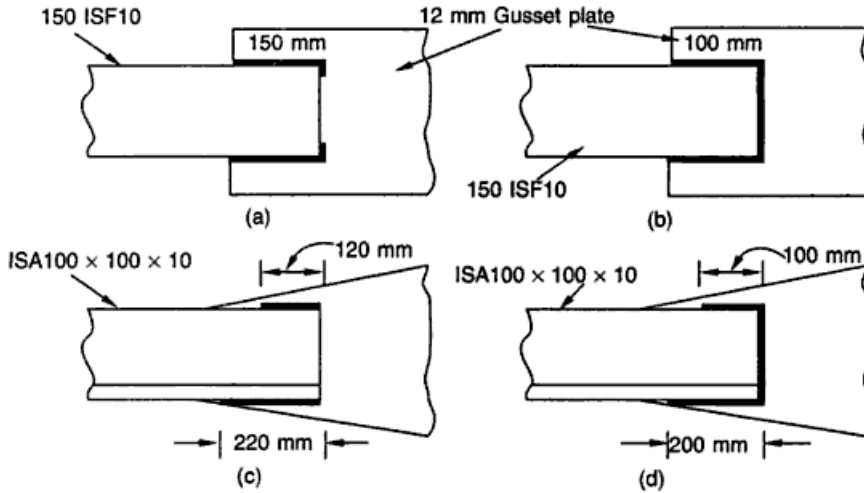

Fig. Prob. 3.3

- 3.4 An angle section 150 mm × 115 mm × 12 mm is to be connected to a gusset plate 12 mm thick. Design the fillet weld to carry a load equal to the strength of the member.
- 3.5 Design a fillet weld to join a tension member consisting of 2 I.S.A. 100 mm × 75 mm × 8 mm to a gusset plate 12 mm thick. The tensile load is 280 kN.
- 3.6 A 120 mm diameter pipe 0.50 m long is welded to 10 mm thick plate at right angles to the plate. A vertical load of 8 kN acts at its free end. The pipe is 6 mm thick. Design the welded connection.
- 3.7 A 200 mm wide and 16 mm thick plate is to be connected with a 8 mm fillet weld. Determine the length L required to develop the full strength of bar (Fig. Prob. 3.7).

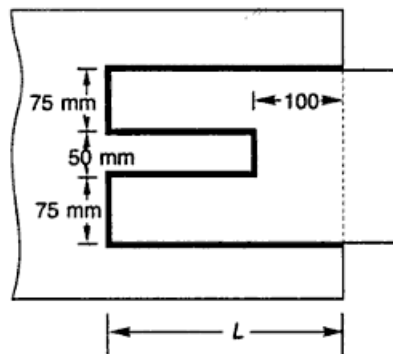

Fig. Prob. 3.7

Compression Members

c
h
a
p
t
e
r
4

4.1 INTRODUCTION

A *compression member* is a structural member which is straight and subjected to two equal and opposite compressive forces applied at its ends. Different terms are used for a compression member depending upon its position in structures. *Strut* is a compression member used in the roof truss and bracing. They are of a small span and may be vertical or inclined. *Column*, *stanchion* or *post* is a vertical compression member supporting floors or girders in a building. These compression members are subjected to heavy loads. The *principal rafter* is a top chord member in a roof truss and *boom* is the principal compression member in a crane.

Stability plays an important role in the design of compression members. Ordinary structural analysis is based on the condition of stable equilibrium between internal and external forces, and a linear relationship is assumed to exist between stress and strain. However when buckling is involved, it is necessary to investigate the potentially unstable equilibrium between the external and internal responses that are further complicated by the complex stress-strain relationship of the material extending from elastic to inelastic range. The term unstable used here pertains to a condition in which the slightest increment of deflection results in a further increase, which may lead to collapse of structure.

Excessive compression of long columns may cause yielding or buckling. It can fail due to yielding if it is absolutely straight, has perfectly homogeneous material, concentric loads and no initial residual stresses. These are ideal conditions which may never exist in an actual structure. As compressive loading of a column is increased, it eventually causes some eccentricity. This in turn sets up some bending moment, causing the column to deflect or buckle slightly. This deflection increases the eccentricity and thus the bending moment. This may progress to where the bending moment is increasing at a rate greater than the increase in load, and the column soon fails by buckling. In general long columns fail by elastic buckling, intermediate columns by inelastic buckling, and very short columns usually fail by crushing or yielding. At the point of failure, the stress in a long column will not exceed the proportional limit and it may be much lower than this limit for a very slender column. Failure of the intermediate column occurs after the extreme fibres have reached the yield point. A very short column is not really a column as such but is considered to be a block without buckling.

In any case, some maximum compressive stress can be set as a limit of strength, and an allowable working stress is chosen accordingly. Also it is logical to apply a large factor of safety to a long column and a smaller factor of safety to a shorter

one. It should be taken note of that the terms long, intermediate and short columns are only relative. They are defined by the interpretation of their slenderness ratio.

This chapter will discuss the design of individual compression members in order to illustrate the detailed procedure involved in selecting appropriate proportions of such members.

4.2 EFFECTIVE LENGTH

The form of curve into which a compression member tends to deflect depends upon the mode of end fixtures. In each case there is a portion of the length of the compression member which bends as if this part had been a pin-jointed end. The end points of this portion of the compression member are the points of contraflexure.

The effective length, l , of a compression member is the distance between these points. Therefore it should be derived from the actual length and end conditions. The end conditions are accounted for through the use of effective length factors, which when multiplied by the actual length L give the effective length. Since the effective length is based on the end conditions of the compression member a precise determination of the effective length is very difficult and any arbitrary assumption may lead to serious errors. Tables 4.1 and 4.2 provide the effective length of columns and struts respectively, for various end conditions.





An angle strut may be a continuous or a discontinuous strut. A continuous strut is a compression member which is continuous over a number of joints, such as a top chord member of a truss bridge girder, principal rafter of a roof truss, etc. In the chord members of roof truss, double unequal angle sections with their short legs placed back to back on the opposite side of the gusset plate are used. This provides greater overall stiffness to the truss against lateral bending. A discontinuous strut is a compression member which extends between two adjacent joints only, e.g., vertical or inclined compression members in a roof truss.

Table 4.1 Effective Length of Columns

End Restraints	Effective Lengths	Figure No.
(a) Effectively held in position at both ends but not restrained against rotation	$1.00L$	4.1(a)
(b) Effectively held in position at both ends and restrained against rotation at one end.	$0.80L$	4.1(b)
(c) Effectively held in position and restrained against rotation at both ends.	$0.65L$	4.1(c)
(d) Effectively held in position and restrained against rotation at one end, and at the other end restrained against rotation but not held in position.	$1.20L$	4.1(d)
(e) Effectively held in position and restrained against rotation at one end, and at the other end partially restrained against rotation but not held in position.	$1.50L$	4.1(e)
(f) Effectively held in position at one end but not restrained against rotation, and at the other end restrained against rotation but not held in position.	$2.00L$	4.1(f)

(Contd.)

Table 4.1 (Contd.)

End Restraints	Effective Lengths	Figure No.
(g) Effectively held in position and restrained against rotation at one end, but neither held in position nor restrained against rotation at the other end.	2.00L	4.1(g)
End conditions		
	Rotation fixed and translation fixed	
	Rotation free and translation fixed	
	Rotation fixed and translation free	
	Rotation free and translation free	

Notes

- (i) For battened compression members the effective length should be increased by 10%.
- (ii) In the case of stepped columns, Appendix D of I.S. 800-1984 may be referred to.

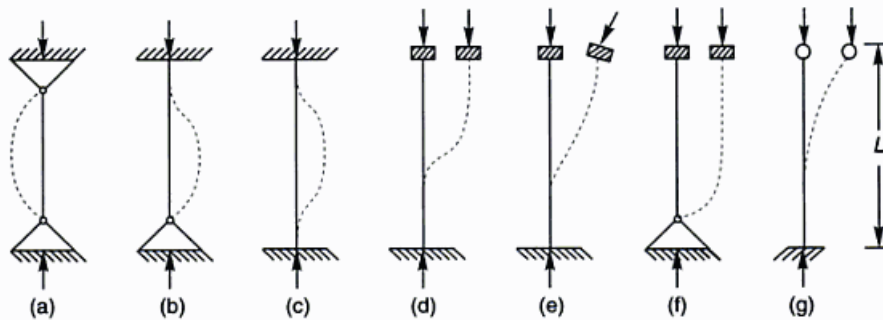
Fig. 4.1 End Restraint of Compression Member
Table 4.2 Effective Length of Struts

Type	Sections	Effective Lengths	Allowable Compressive Stress	Figure No.
1. Continuous	Single or double angle	0.7L to 1.00L	σ_{ac}	4.2(a)
2. Discontinuous	Single angle connected with one rivet	1.00L	$0.8\sigma_{ac}$	
3. Discontinuous	Single angle connected with more than one rivet or with weld.	0.85L	σ_{ac}	4.2(b)
4. Discontinuous	Double angles placed back to back on opposite sides of gusset plate	0.70L to 0.85L	σ_{ac}	4.2(c)
5. Discontinuous	Double angles placed back to back on same side of gusset plate	1.00L	$0.8\sigma_{ac}$	4.2(d)

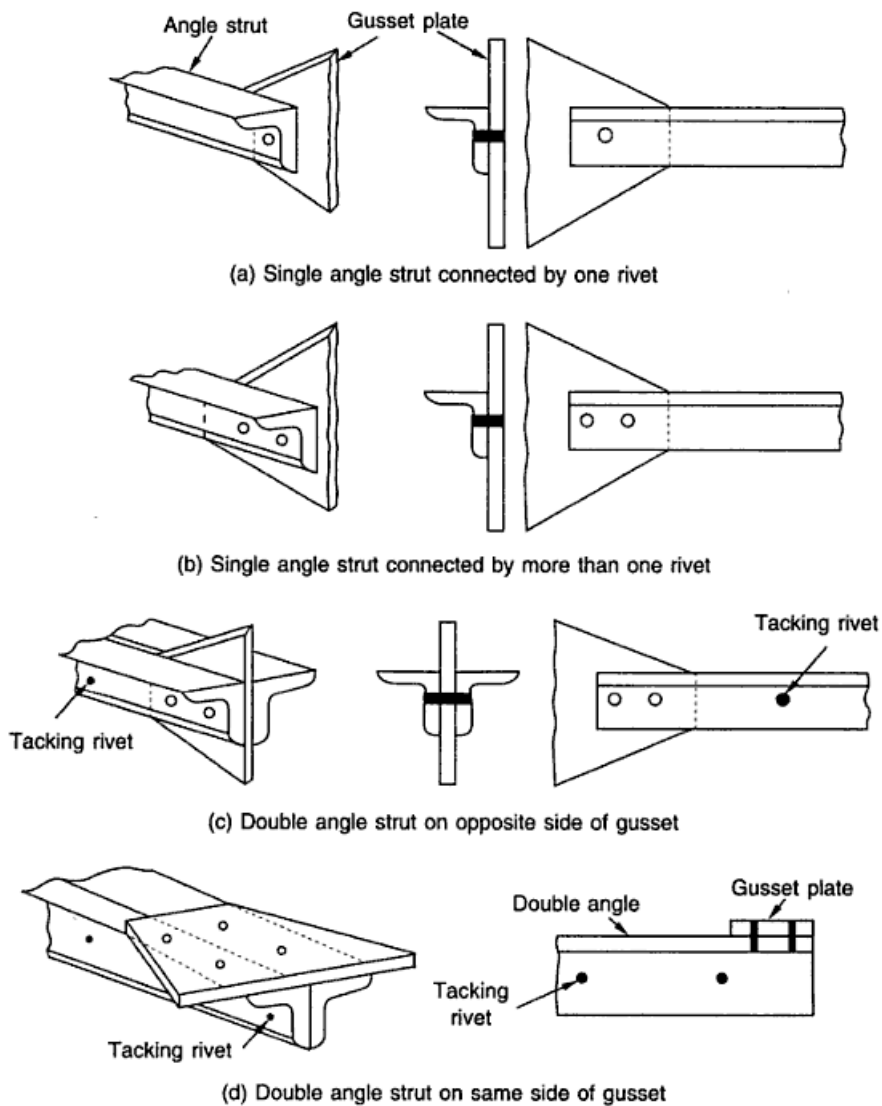

Fig. 4.2 End Restraint of Struts

4.3 SLENDERNESS RATIO (λ)

The slenderness ratio of a member is the ratio of the effective length to the appropriate radius of gyration ($\lambda = kL/r$). This is valid only when the column has equal unbraced heights for both axes and end conditions are same for both axes. The appropriate radius of gyration is one which is minimum for a particular section. For example a section asymmetrical about the centroidal axes (angle section, Fig. 4.3) will bend about the principal axis $V-V$ for which the radius of gyration is minimum. On the other hand, a section symmetrical about both the centroidal axes (I-Section) or even with one axis of symmetry (channel section, two angles back to back) will

bend about one of the centroidal axis giving lesser radius of gyration. This is because for such sections the principal axes coincide with the centroidal axes.

The slenderness ratios about XX and YY axes are,

$$\lambda_{XX} = l_{XX}/r_{XX} \quad r_{XX} = \sqrt{I_{XX}/A}$$

$$\lambda_{YY} = l_{YY}/r_{YY} \quad r_{YY} = \sqrt{I_{YY}/A}$$

and $\lambda_{\max} = l/r_{\min} \quad r_{\min} = \sqrt{I_{\min}/A}$

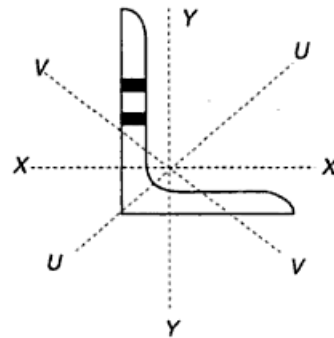

Fig. 4.3 Axes of Angle Section

To minimise steel requirements in column design (so as to use the material at the greatest possible stress) the slenderness ratio should be kept as small as possible. The designer can achieve this either by selecting a section which provides the largest value of the minimum radius of gyration without providing more area or by reducing the unsupported length of the column by some means.

Maximum radius of gyration is obtained when material is farthest from the centroid. Thus, for a constant area the material gets thinner as the column size increases and in such a case local buckling limits the column size.

If feasible, the unsupported length can be reduced by furnishing intermediate supports to a compression member by attached construction and thus permitting use of a smaller section at high average stress. If this is possible in only one direction, then the value of the unsupported length will be different for the two directions. Sections with different radii of gyration in two directions may be so chosen as to obtain the values of the two slenderness ratios λ_{xx} and λ_{yy} with least difference (see Example 4.9). The larger of the two would be used for the determination of the nominal axial compressive stress. It would be desirable to orient the section so that the axis having the smallest radius of gyration would be the one braced. Sometimes when the conditions at the column end, about the two axes are different, a balance between the two slenderness ratios (λ_{xx} and λ_{yy}) can be achieved by properly orienting the section and the material can be used to its maximum stress value. An I-Section electric pole fixed at the base and carrying wires parallel to the road is an example wherein the wires provide a hinge condition in the direction of wires ($l = 0.8L$) and with free end condition in the perpendicular direction ($l = 2L$). The section is used to its full strength by providing flanges parallel to the direction of wires and thus attempting to equalise λ_{xx} and λ_{yy} .

$$\lambda_{xx} = \frac{0.8L}{r_{yy}}, \quad \lambda_{yy} = \frac{2L}{r_{xx}}$$

The slenderness ratio of compression members is limited because of the following reasons:

1. The effect of accidental and construction (fabrication, transportation and erection) loads are automatically taken care of.
2. The bracing members may be used as a walkway for workmen or to provide temporary support for equipments.
3. To take care of the probability of members being subjected to unexpected vibrations.

The maximum permissible slenderness ratio for compression members are stated in Table 4.3.

Table 4.3 Maximum Slenderness Ratio (λ) for Compression Members

S. No.	Type of Member	λ
1.	A strut connected by single rivet at each end	180
2.	A member carrying compressive loads resulting from dead loads and imposed loads	180
3.	A member subjected to compressive forces resulting from wind/earthquake forces, provided the deformation of such members does not adversely effect the stress in any part of the structure	250
4.	Compression flange of a beam	300
5.	A member normally acting as a tie in a roof truss or a bracing system but subjected to possible reversal of stresses resulting from the action of wind or earthquake forces	350

4.4 COLUMN DESIGN FORMULA

The failure of columns excluding the possibility of torsion, is due to bending. The factors that influence the bending behaviour in real columns are, lateral loads, end eccentricity, column curvature and non-homogeneity of material, etc. These factors should be given due consideration. Residual stresses, variation in inelastic stress-strain characteristics, shear strength, local buckling, shape of cross section and end restraints are some of the factors that effect the buckling resistance of columns. It is impractical to incorporate all the factors that affect the strength of the column mathematically in any one column formula. A number of formulae have been suggested by designers. I.S: 800-1984 recommends the use of *Merchant Rankine formula* (with a f.o.s. of 1/0.6).

Merchant Rankine formula in its fundamental form is

$$\frac{1}{(f)^n} = \frac{1}{(f_e)^n} + \frac{1}{(f_y)^n} \quad (4.1)$$

or

$$f = \frac{f_e \times f_y}{[(f_e)^n + (f_y)^n]^{1/n}} \quad (4.2)$$

where f_e is the elastic critical stress (same as f_{cc} used by I.S. code) and f_y is the failure stress.

The direct stress in compression on the cross-sectional area of an axially loaded compression member is limited to $0.6 f_y$. Therefore, the formula for permissible compressive stress derived from the Merchant Rankine formula is,

$$\sigma_{ac} = 0.6 \frac{f_{cc} f_y}{[(f_{cc})^n + (f_y)^n]^{1/n}} \quad (4.3)$$

where σ_{ac} = permissible stress in axial compression in MPa
 f_y = yield stress of steel, in MPa

$$f_{cc} = \text{elastic critical stress in compression} = \frac{\pi^2 E}{\lambda^2}$$

λ = slenderness ratio

n = A factor assumed as 1.4 (ranges between 1-3)

The values of σ_{ac} based on the above formula for some of the I.S. structural steels (for yield stresses from 220 N/mm² to 540 N/mm²) are stated in Table 4.4 of the text. The Merchant Rankine formula gives the average allowable compressive stress for the compression member. Note that it does not give the actual unit stress developed in the compression members by the load. The unit stress resulting from this formula when multiplied by the cross-sectional area of the compression member gives the allowable load which may be supported.

4.5 TYPES OF SECTIONS

Requirements for compression members are more demanding than those for tension members, for here the carrying capacity is a function of the shape as well as the area and also the material properties. The material must be disposed so as to resist effectively any tendency towards general or local instability. Thus the member must be sufficiently rigid to prevent general buckling in any possible direction, and each plate element of the member must be thick enough to prevent local buckling.

The most important property of the section in a compression member is the radius of gyration and thus the moment of inertia and it can be increased by spreading the material of section away from its axis (the material closer to the axis contributes less to it). An ideal section is one which has the same moment of inertia about any axis through its centre of gravity.

Various types of sections with which the students are already conversant may be used as single sections or in combination with either the same or different cross-sections. Of course, the practicability and availability of the sections will have to be ensured. Rolled steel sections cost less than the built-up sections per unit weight and are therefore, preferred.

Rods and bars withstand very little compression when length is more. Hence these are recommended for lengths less than 3 m only.

Tubular sections are most suitable for small loads and lengths. These sections are usually provided for roof trusses and bracings. The use of tubes as compression members was limited over decades due to the difficulty in making connections with rivets/bolts. But with the development of welding techniques its use has become frequent for the following reasons:

1. Tubes have the same radius of gyration in all directions and have a high local buckling strength.
2. Tubes have more torsional resistance.
3. In case of members subjected to wind, round tubes are subjected to less force than flat sections.

Table 4.4 Permissible Stress σ_{ac} (MPa) in Axial Compression for Steels with Various Yield Stress

$f_y \rightarrow$ $\lambda \downarrow$	220	230	240	250	260	280	300	320	340	360	380	400	420	450	480	510	540
10	132	138	144	150	156	168	180	192	204	215	227	239	251	269	287	305	323
20	131	137	142	148	154	166	177	189	201	212	224	235	246	263	280	297	314
30	128	134	140	145	151	162	172	183	194	204	215	225	236	251	266	280	295
40	124	129	134	139	145	154	164	174	183	192	201	210	218	231	243	255	267
50	118	123	127	132	136	145	153	161	168	176	183	190	197	207	216	225	233
60	111	115	118	122	126	133	139	146	152	158	163	168	173	180	187	193	199
70	102	106	109	112	115	120	125	130	135	139	142	147	150	155	160	164	168
80	93	96	98	101	103	107	111	115	118	121	124	127	129	133	136	139	141
90	85	87	88	90	92	95	98	101	103	105	108	109	111	114	116	118	119
100	76	78	79	80	82	84	86	88	90	92	93	94	96	97	99	100	101
110	68	69	71	72	73	74	76	77	79	80	81	82	83	84	85	86	87
120	61	62	63	64	64	66	67	67	69	70	71	71	72	73	73	74	75
130	55	55	56	57	57	58	59	60	61	61	62	62	63	63	64	64	65
140	49	50	50	51	51	52	53	53	54	54	54	55	55	56	56	56	57
150	44	45	45	45	46	46	47	47	48	48	48	49	49	49	49	50	50
160	40	40	41	41	41	42	42	42	43	43	43	43	43	44	44	44	44
170	36	36	37	37	36	37	38	38	38	38	39	39	39	39	39	39	39
180	33	33	33	33	33	34	34	34	34	35	35	35	35	35	35	35	35
190	30	30	30	30	30	30	31	31	31	31	31	31	32	32	32	32	32
200	27	27	28	28	28	28	28	28	28	28	28	28	28	28	28	28	28
210	25	25	25	25	25	25	26	26	26	26	26	26	26	26	26	26	26
220	23	23	23	23	23	23	23	24	24	24	24	24	24	24	24	24	24
230	21	21	21	21	21	21	22	21	22	22	22	22	22	22	22	22	22
240	20	20	20	20	20	20	20	20	20	20	20	20	20	20	20	20	20
250	18	18	18	18	18	18	18	18	18	19	19	19	19	19	19	19	19

The least radius of gyration of a single angle section is small as compared to channels and I-Sections and hence, it is not suitable for long lengths. These are therefore, more commonly used as strut in roof trusses with riveted or welded connections. Single angle sections in general should therefore be avoided, where possible. Equal angles are more desirable and economical than unequal ones, because their least radius of gyration is greater for the same area of steel.

Where compression members are designed for very large structures it may be desirable to use built-up sections. When these are used they must be connected suitably on their open sides to hold the parts together in their proper positions and to assist them in acting together as an integral unit.

Double angles placed back to back (Fig. 4.4(a)) or with legs spread (Fig. 4.4(b)) are most suited for trusses. For a double angle section back-to-back, it is desirable to use unequal angles with the long legs back-to-back to achieve a balance between radius of gyration values about the X and Y axes.

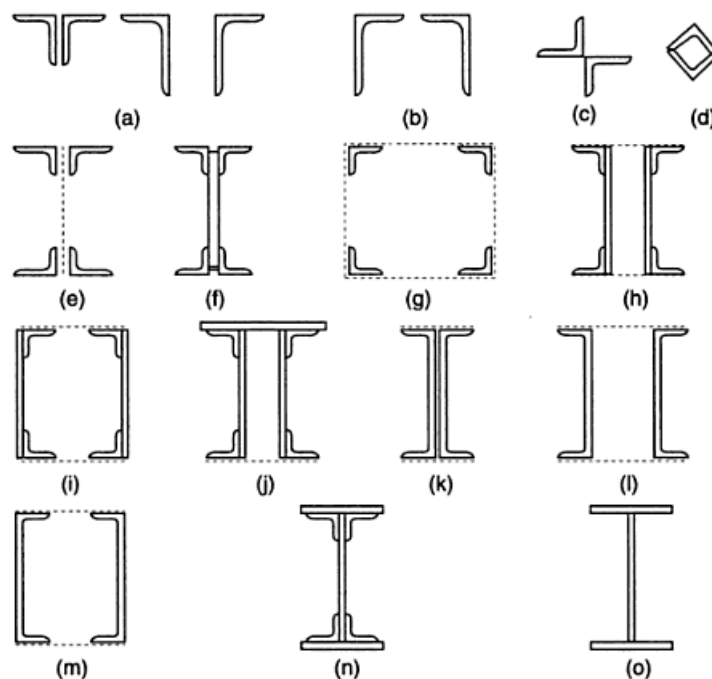

Fig. 4.4 Shapes of Compression Members

When the legs are spread, the least radius of gyration is same as that when placed back-to-back. The stiffness of double angle sections with legs spread is greater than when placed back-to-back but this is uneconomical because of the additional cost of lacing and riveting. However, it has no advantage over a double angle placed back-to-back regarding the least radius of gyration. Two angle sections can also be used in the form of a star (Fig. 4.4(c)). This cruciform arrangement of double angles is most effective because of its approximately equal radii of gyration in two directions. The box section can be formed with welded connection (Fig. 4.4(d)). The least

radius of gyration of the section shown in Figs 4.4(c) and (d) of two equal angles is same and is more than that of the sections shown in Fig. 4.4(a, b).

Four angle sections can be used as shown in Fig. 4.4(e-g). The built-up section shown in Fig. 4.4(e) is provided when the load is small. For higher loads the section shown in Fig. 4.4(f) is preferred. In order to obtain higher values of least radius of gyration in shapes (e) and (f), the longer legs of unequal angles should be kept horizontal, as indicated. The section shown in Fig. 4.4(g) is used for moderate loads and large length, i.e. when the least radius of gyration required is large but due to excessive lacing it is uneconomical. The connecting systems can be replaced by plates on one side or on more than one side, when a greater cross-sectional area is required or where stiffer bracing between the parts is necessary, as shown in Fig. 4.4(h), (i), (j). Such sections are normally provided in bridge trusses.

Two channels placed back-to-back (Fig. 4.4(l)) result in a small value of radius of gyration about y - y axis and are, therefore, seldom recommended. Two channels spaced apart (Fig. 4.4(l)) constitute a good section. Two channels placed face to face (Fig. 4.4(m)) provide a larger value of radius of gyration as compared to channels back-to-back (Fig. 4.4(l)) and separated apart for the same spacing. Thus two channels face to face are the ideal section for compression members as these provide more rigidity. However, when a large radius of gyration is not the criteria for the type required, channels are placed back-to-back as the lacing is minimised. Also the exposed location of both ends of each rivet makes it easier to fabricate and further lower the cost. Channels placed face to face are also called placed toe-to-toe or placed with flanges turned inwards.

The dotted lines in the sections shown in Fig. 4.4 represent connecting systems such as lacings, etc., or discontinuous parts and the solid lines represent parts that are continuous for the full length of members.

Generally rolled I.S.H.B. section with additional intermediate support in the weak direction are used as column sections. For large loads, when rolled I-Section do not suffice, an I-Section can be built up with plates and angles in case riveted connections are done (Figs 4.4(f) and (n)). On the other hand, such a section is built up with plates only if welded connections are done (Fig. 4.4 (o)). Two I-Sections laced together can also be used for higher loads.

4.6 BUCKLING

When an axially loaded compression member becomes unstable overall (that is, not locally unstable), it can buckle in one of the following of three ways.

Flexural Buckling It is a deflection caused by bending, or flexure, about the axis corresponding to the largest slenderness ratio. This is usually the minor principal axis—the one with smallest radius of gyration. Compression members with any type of cross sectional configuration can fail in this way.

Torsional Buckling The flexural buckling considered above is due to bending alone, that is, the sections displace from their original position by translation without rotation. Thin wall members with open cross-sectional shape are sometimes weak in torsion and hence may buckle by twisting rather than bending. Torsional buckling occurs when the torsional rigidity of the member is appreciably smaller

than its bending rigidity. This type of failure is caused by twisting about the longitudinal axis of member. It can occur only with doubly symmetrical cross sections with very slender cross-sectional elements. Standard hot-rolled shapes are not susceptible to torsional buckling, but a member built from thin plate elements may be and should be investigated. The cruciform shape shown in Fig. 4.4(c) is particularly vulnerable to this type of buckling.

Flexural-torsional Buckling This type of failure is caused by a combination of flexural buckling and torsional buckling. The member bends and twists simultaneously. This type of failure can occur only with unsymmetrical cross-sections, both those with one axis of symmetry—such as channels, structural tees, double angle shapes, and equal-leg single angles—and those with no axis of symmetry, such as unequal-leg single angles.

Generally, the specifications require an analysis of torsional or flexural-torsional buckling only when appropriate.

4.7 DESIGN OF AXIALLY LOADED COMPRESSION MEMBERS

Following are the assumptions made while designing a column.

1. The ideal column is assumed to be absolutely straight having no crookedness, which never occurs in practice.
2. The modulus of elasticity is assumed to be constant in a built-up column.
3. Secondary stresses (which may be of the order of even 25%–40% of primary stresses) are neglected.

The cross-sectional shape of an axially loaded column depends largely on the length and load on the column. In its design information required will be the length of the member, the end conditions and the loads it has to support. The designer is supposed to select a section which provides a large radius of gyration without providing more area and in which the average compressive stress does not exceed the allowable compressive stress. To compute these stresses, the cross-sectional area and the radius of gyration must be known. So there are two unknowns and it becomes essential to assume one out of the two based on some principles, and compute the other. The section is then checked for safety. The procedure is thus of trial and error and is as follows:

1. Average allowable compressive stress in the section is assumed. It should not be more than the upper limit for the column formula specified by the relevant code.
2. The cross-sectional area required to carry the load at the assumed allowable stress is computed.

$$A = \frac{P}{\text{allowable compressive stress}}$$

where A is the tentative cross-sectional area required (in mm^2), and P is the load on column in Newtons.

3. A section that provides the estimated required area is selected from I.S. Hand Book No. 1. The section is so chosen that the minimum radius of gyration of the section selected is as large as possible. The appropriate least radius of gyration for the section selected is recorded.

4. The effective length of the column is calculated on the basis of end conditions, from Table 4.1 or Table 4.2 as appropriate, and the slenderness ratio is computed ($\lambda = l/r$), which should be less than the permissible slenderness ratio (Table 4.3).
5. For this estimated value of slenderness ratio, the maximum allowable compressive stress, σ_{ac} is calculated from Table 4.4 of the text. In case of struts this value may have to be reduced to 80 per cent depending upon the case as indicated in Table 4.2.
6. The load carrying capacity of the member is computed by multiplying the maximum compressive stress thus obtained with the cross sectional area provided. This value of the load carrying capacity of the member should be more than the load to be supported by it.

Notes

1. To assume allowable compressive stress in the first step of the design procedure, reference may be made to Table 4.4 of the text. For steel with $f_y = 250$ MPa a trial value of allowable compressive stress may be assumed between 60-85 MPa for struts and 85-110 MPa for columns.
2. Note that steps 1 and 2 are only for beginners. An experienced designer will select a section straightaway from IS Hand Book No. 1 and will apply check for its safety and economy.
3. If the load carrying capacity of the column exceeds the load over the column by more than 5%, the section needs a revision (being oversafe and uneconomical). However, many-times it may not be possible due to the limitation of sections available.

4.8 BUILT-UP COLUMNS (LATTICED COLUMNS)

The size and shape of standard rolled steel sections are limited because of the limitations of rolling mills. When rolled sections do not furnish the required sectional area or when a special shape or large radius of gyration is required in two different directions a built-up section is fabricated.

To achieve economy in the design of heavily loaded long columns the least radius of gyration of column section is increased to maximum. Rolled sections are kept away from the centroidal axis of the column and are connected by some connecting system. The commonly used lattice are lacing bars (Fig. 4.5(a), (b) and (d)), batten plates (Fig. 4.5(c)), lacing with battens (Fig. 4.7(e)) and, perforated cover plates.

When lacings are provided with battens, the shear component of the axial load tends to expand the column laterally. Because of lacing an accordion-like action of the system exists which means the lateral expansion of the column must accompany shortening under load, if there is to be no shortening of lacing bars. The introduction of battens restrain this action and the lacing system with battens behaves as a truss which may result in large stresses leading to failure. Therefore lacing with battens is not recommended.

When four angles are used as a built-up column, lacing is staggered (Fig. 4.5(d)). If the lacing connections in the two adjacent faces are made to coincide then the angle is fully restrained at that point and tends to buckle between the lacing connections in the weak direction (bending about $V-V$ axis). On the other hand, if the lacing connections are staggered in the two adjacent faces then the angle is not fully restrained at the connections and tends to buckle along an axis other than $V-V$.

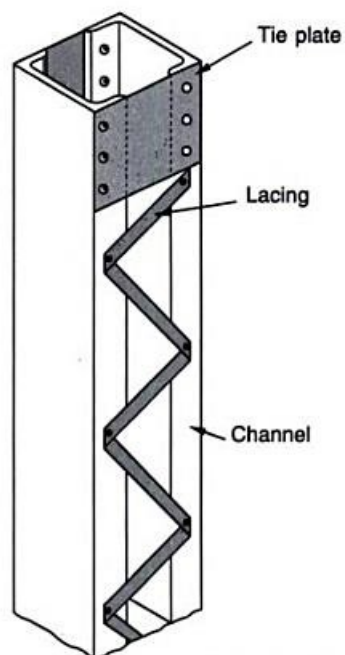

(a) Channels Face-to-face Connected by Single Lacing

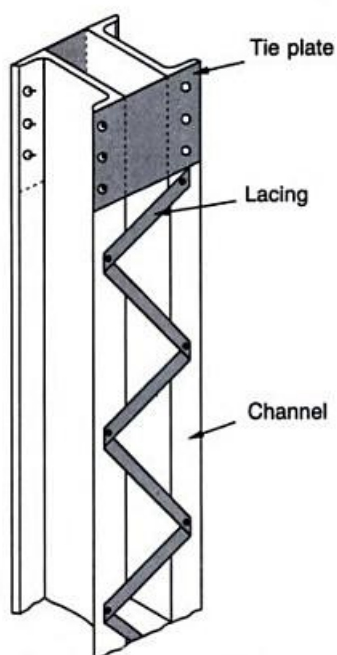

(b) Channels Back-to-back Connected by Single Lacing

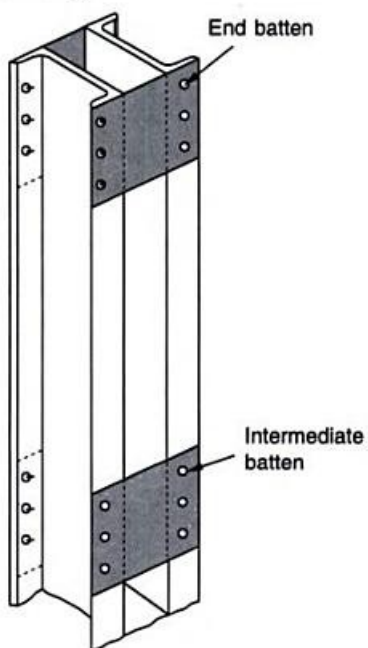

(c) Channels Back-to-Back Connected by Battens

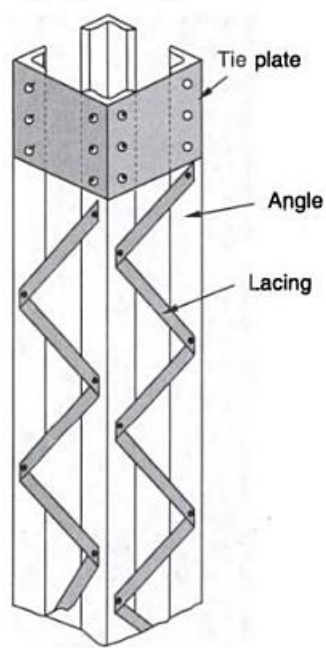

(d) Angles Connected by Single Lacing (Shown on two faces only)

Fig. 4.5 Built up Columns

Lattice, the lacing bars and batten plates, are not load carrying elements. Their function is primarily to hold the main component members (different sections) of the column in their relative position and equalize the stress distribution in them. They also provide points of intermediate support for each separate part of a built-up column. Thus for a built-up column lacings or battens are economical only if the increase in permissible stress for the load carrying members permit a greater reduction in weight than what is added by lacing or batten. However a built-up column, designed as an axially loaded column, may be accidentally loaded eccentrically or may have initial crookedness. Variable bending moments will be induced in such columns because of the eccentricity between the centroidal axis of the column and line of action of the applied load. Due to this there will be related shear forces in the plane of the cross-section and in the connecting system. The lattice must be capable of resisting the following loads: stresses due to external transverse loads on the column, stresses due to the deflected shape of the column, stresses due to shortening of main segments and stresses due to crushing induced by the curvature of the column. Usually, the latter two are negligible and are not considered in the design. The codes specify a minimum value of shear component as specified percentage of axial load on column to be considered in design.

Built-up columns are formed by using two or more structural shapes called main segments. These may in turn be assumed to be made up of a series of small columns of length C (Fig. 4.6(b)), formed due to the open lattice connection and are called the component columns. If this length C is large the component columns may buckle alternately in and out between the connections and the buckling would be as of pin-ended columns. The necessity of connecting the component members of a built-up column can be understood better by considering a compression member composed of several main component members, each of which will tend to buckle laterally if not tied together to act as an integral unit to support the load. If there were no such connection, each branch would be subjected under load to buckling with respect to its own axis. When connecting systems are installed, the stiffness of the column as a whole increases considerably. The sections used to form the column

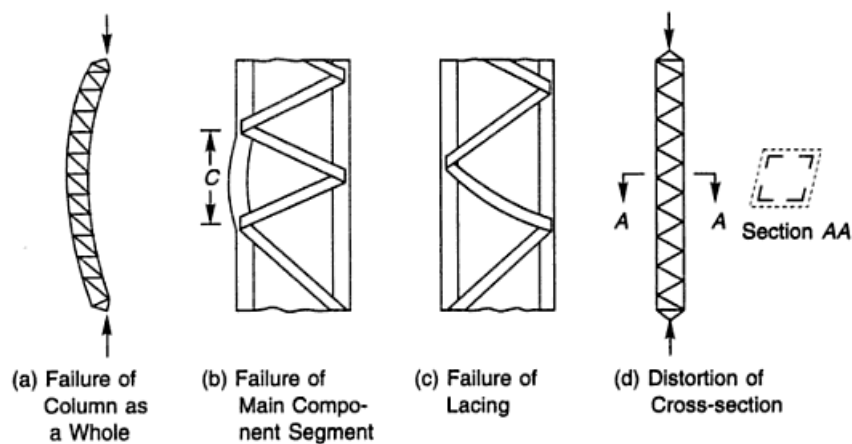

Fig. 4.6 Failure Modes of a Latticed Column

act as a single section, withstanding buckling with respect to the axis about which the sections were spaced.

The buckling strength of a latticed column is smaller than that of solid column having the same area and the same slenderness ratio provided that the solid column does not buckle locally because of thinness of material. This is because the shearing component of the axial load produces deformation in the lattice which tend to reduce the over-all stiffness of the column and therefore reduce the buckling strength of the column.

In the design of built-up columns the following conditions are considered, which are illustrated by a four angle section lattice column (Figs 4.6(a)–(d)).

1. Buckling of the column as a whole under the axial load (Fig. 4.6(a)).
2. Buckling of the component column (Fig. 4.6(b)).
3. Failure of lattice member (Fig. 4.6(c)).
4. Distortion of the cross-section (Fig. 4.6(d)).

4.9 LACING

Flat or angle sections are normally used as lacings. The purpose of lacing is to hold the various parts of a column straight, parallel, at a correct distance apart and to equalize the stress distribution between its various parts. Various arrangements of lacings with two channels back-to-back are shown in Figs 4.7(a)–(e). The firm lines representing lacings show single lacing on one face and the dotted lines represent lacing on the other face (Fig. 4.7 (a–c)). Double lacing system is shown in Fig. 4.7(d). Lacings can also be used with battens as shown in Fig. 4.7(e), but this arrangement is not preferred as it gives undesirable effects. Lacing bars should not

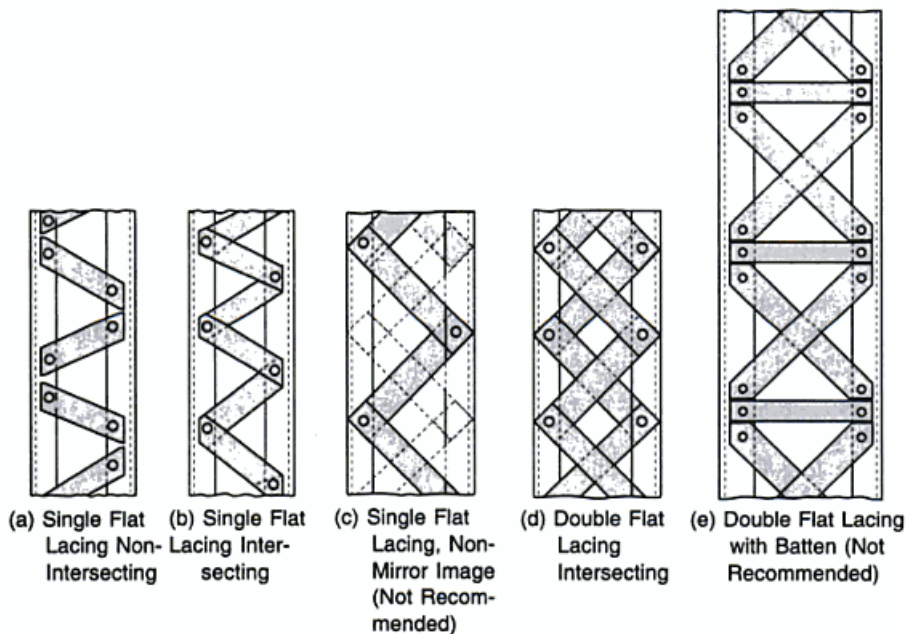

Fig. 4.7 Lacing Systems

project beyond the column section. Usually these are connected with a single rivet at the end but sometimes two rivets are provided assuming that one rivet out of the two may be faulty, though the stresses are normally small and only one rivet may be sufficient. There may be possibility that a rivet connecting the lacing flat at a point fails, then the length C (Fig. 4.6(b)) of the component member will become double. This possibility can be overcome by either lacing the sections as shown in Fig. 4.7 (a) or by lacing the column on the far end as shown in Fig. 4.7(c). The latter is not recommended by the I.S. code. Single or double lacings can be provided depending upon the criteria discussed below and are then designed as compression members. The transverse shear force for which the lacing system is satisfactory if properly designed is usually very small and single lacing system is sufficient, but the designers consider double lacing system to be superior though uneconomical, and recommend it.

Design

The following are the steps in the design of laced columns:

1. Average allowable compressive stress is assumed. For steel with $f_y = 250$ MPa a beginner may assume a trial value between 110–150 MPa.
2. Required cross-sectional area to carry the load at the assumed allowable stress is computed.

$$A = \frac{P}{\text{allowable compressive stress}}$$

where A = cross-sectional area in mm^2 .

3. Select two channels or four angles or two I-sections with or without extra plates as required, from I.S. Handbook No. 1. The area provided is recorded.
4. The sections are so spaced that the radius of gyration of the section about the axis perpendicular to the plane of lacing should not be less than the radius of gyration about the axis in the plane of lacing. This is achieved by making the radius of gyration about the YY -axis equal to or greater than that about the XX -axis.
5. The effective length of the column is estimated and the slenderness ratio determined.
6. For the estimated value of the slenderness ratio the maximum allowable compressive stress σ_{ac} is computed from Table 4.4 of the text.
7. The load carrying capacity of the member is computed. It should be more than the load coming over the section.

$$\text{Load carrying capacity} = \sigma_{ac} A > P$$

8. Angle of inclination θ of the lacing bar with the longitudinal axis of the component member should be kept between 40° – 70° , as per I.S. specifications.
9. The maximum spacing of lacing bars C should be such that the minimum slenderness ratio of the component member c/r_{yy} is not greater than 50 or 0.7 times the slenderness ratio of the member as a whole, where C is the length of component member and r_{yy} is the radius of gyration about YY -axis of the component member.

Note In the single lacing system, to satisfy this criteria the angle θ can be increased from 40° up to 70° only. If still the component column is found to be unsafe a double lacing system remains the only choice.

- The lacing for compression member should be proportioned to resist a total transverse shear V equal to 2.5% of the axial force in the column. This shear V is divided equally in all parallel planes N in which there are shear resisting elements, such as lacing or continuous plates. Hence V/N is the transverse force to which the lacing is subjected (Fig. 4.8).

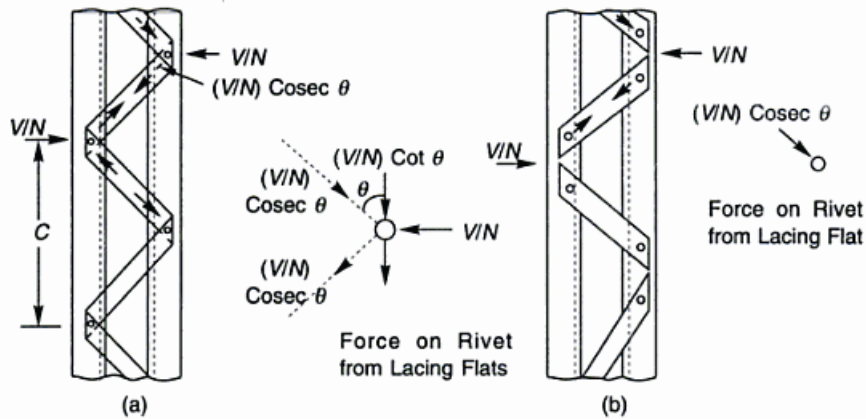

Fig. 4.8 Force in Lacing and Connector

Notes

- $N = 2$ for two channels laced on both faces or four angles laced on all the faces.
- To the shear V so determined any shear due to the weight of the member or due to other forces, is added and the lacing is proportioned for the combined shear.
- The compressive force in the lacing bar is computed, which is equal to $(V/N) \operatorname{cosec} \theta$ for single lacing system and $(V/2N) \operatorname{cosec} \theta$, for a double lacing system.
- The section of the lacing flat is initially assumed and then checked for safety.

Width First of all the diameter of the rivet is assumed. Depending upon this the flat width is selected from Table 4.5.

Table 4.5 Width of Lacing Flat

Nominal Diameter of Rivet in mm	Width of Lacing Flat in mm
16	50
18	55
20	60
22	65

Thickness If single lacing system is adopted, the thickness t of lacing flat $\nless 1/40$ of the length between the inner end rivets or welds. If double lacing system is adopted, the thickness t of the lacing flat $\nless 1/60$ of the length between the inner end rivets or welds.

Note Rolled sections other than flats, e.g. angle sections and tubes can also be used as lacing.

13. Minimum radius of gyration for the lacing flat is computed, $r = t/\sqrt{12}$.
14. The slenderness ratio of the lacing bar is computed which should be < 145 . In a riveted construction, the effective length of the lacing bar is the length between the inner end rivets for a single lacing system and 0.7 times of this distance for a double lacing system. In welded constructions, the effective length of the lacing bar is 0.7 times the distance between the inner ends of the welds connecting the lacing bars to the member.
15. The compressive strength of the lacing flat is computed for the calculated value of the slenderness ratio of the lacing flat. This should be more than the force on the flat.
16. The tensile strength of the flat, which is equal to $(b - d)t \sigma_{at}$ and should be more than the force on the lacing flat, is calculated.
17. In case of riveted constructions, the rivet value is calculated and should be more than the load coming over the rivet. In case the two lacing flats are riveted at same point the load over the rivet will be $2(V/N) \cot\theta$, whereas for lacing flats connected at different points the load on the rivet will be $(V/N) \operatorname{cosec} \theta$. In case of welded construction, the welding of lacing bars to the main members should be sufficient to transmit the load in the bars. Welding should be provided along each side of the lacing bar for the full length of the lap. The overlap of lacing bar should not be less than four times the thickness of the bar or the member, whichever is less.
18. To check the distortion of the column section at the column ends tie plate (batten) is provided at the end of the lacing system and this should be able to resist the forces to which the lacing flat is subjected. The tie plate is designed as a batten plate.

4.10 BATTEN

Battens are plates or any other rolled sections used to connect the main components of compression members. Battens should be placed opposite to each other on the two parallel faces and should be spaced and proportioned uniformly throughout, as shown in Fig. 4.9. The number of battens should be such that the member is divided into at least three bays within its actual length. Battens provided at the ends of columns are called end battens and all other battens are called intermediate battens. Battened columns have the same strength as laced columns but are uneconomical and are therefore used rarely. Battens are not recommended for a column subjected to an eccentric load in the plane of a connecting system.

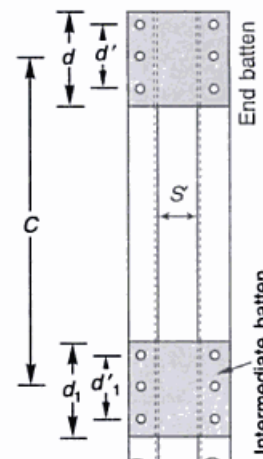

Fig. 4.9 Batten

Design

Column sections to be battened are designed in a way similar to a laced column.

The only difference is in the effective length which is increased by 10% in the case of a battened column. Once the column section is derived (steps 1 to 7 section 4.9.1), the battens can be designed as follows:

1. The maximum spacing of the battens C should be such that the minimum slenderness ratio of the component member C/r_{yy} is not greater than 50 or 0.7 times the slenderness ratio of the member as a whole, about an axis parallel to the battens.
2. The section of the batten is selected as follows and is then checked for the forces to which it is subjected.

Depth The effective depth of the end batten should not be less than the distance between the centre of gravity of the component members and this should be more than twice the width of one component member. The depth of the intermediate batten is taken as 3/4 of the effective depth of the end batten and should be more than twice the width of one component member. Refer to Fig. 4.9 where two channels have been shown placed back-to-back, spaced apart by a distance S' , and connected by battens.

$$\text{Effective depth of end batten } d' = S' + 2c_{yy}$$

$$\text{Overall depth of end batten } d = d' + 2 \times \text{edge distance}$$

$$\text{Effective depth of intermediate batten } d_1' = \frac{3}{4}d'$$

$$\text{Overall depth of intermediate batten } d_1 = d_1' + 2 \times \text{edge distance}$$

where c_{yy} = the distance taken from I.S. Handbook No. 1 for the section

Thickness The thickness t of battens should not be less than 1/50 of the distance between the innermost connecting lines of the rivets or welds.

$$t = \frac{1}{50} (S' + 2g) \quad (\text{for rivets in one row})$$

where g = guage distance taken from I.S. Handbook No. 1 for that particular section.

Note The above requirements of size and thickness do not apply if rolled sections, e.g., angles, channels, I-Sections, etc. are used as battens.

3. Battens should be designed to carry the bending moment and shear arising from the transverse shear force, V , which is 2.5% of the total axial force on the whole compression member. This transverse shear force is divided equally in all the parallel planes N in which there are shear resisting elements such as battens or continuous plates battens.
4. Battens should be able to resist the longitudinal shear and moment arising from the transverse shear V (Fig. 4.10).

$$V_1 = \frac{VC}{NS}; \quad M = \frac{VC}{2N}$$

where V_1 is the longitudinal shear force, V is the transverse shear force, C is the centre to centre distance of battens and S is the minimum transverse distance between the centroids of the rivet group/weld.

Moment

The Two Forces $V/2N$ Equal and Opposite at Distance C , Give Rise to Moment,

$$M = \frac{V}{2N} \times C = \frac{VC}{2N}$$

Longitudinal Shear

$$V_1 = \frac{VC/2N}{S/2} = \frac{VC}{NS}$$

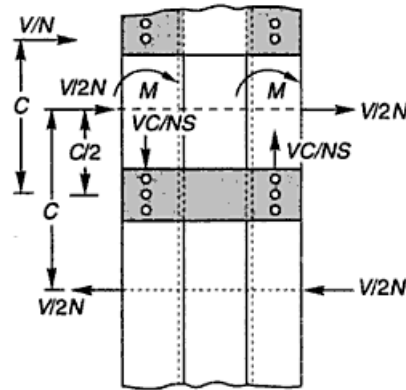

Fig. 4.10 Forces on Battens

5. The average shear stress is calculated in the section of battens and it should be less than the allowable average shear stress.
6. The bending stress in the section of the batten is calculated and it should be less than the allowable bending stress ($0.66f_y$).

$$\sigma_{bc, cal} = \frac{M}{Z} = \frac{M}{\frac{1}{6}td^2} = \frac{6M}{td^2}$$

7. The connection (riveted/welded) is designed to resist the longitudinal shear and bending moment. If riveted construction is done; not less than two rivets should be used. If welded construction is done, the aggregate length of weld on each edge (parallel to the depth) should not be less than half the depth of batten plate. At least one third of the weld should be placed at each end of this edge.

4.11 COMPRESSION MEMBERS COMPOSED OF TWO COMPONENTS BACK-TO-BACK

The compression members may also be designed as two rolled sections placed back-to-back and not connected by any connecting systems as has been discussed in Section 4.8. In such a case, the following specifications given by I.S: 800–1984 may be followed;

1. Two rolled sections when placed back-to-back or separated by a small distance should be connected together by rivets or welds so that the slenderness ratio of each member between the two consecutive connections is not greater than 40 or 0.6 times the slenderness ratio of the column as a whole.
2. The ends of the strut should be connected together with not less than two rivets or an equivalent weld and there should not be less than two additional connections spaced equidistant in the length of the strut. When there is small spacing between the two sections, washers and packings should be provided to make connections. When the legs of angles or the table of Tee is ≥ 125 mm or where web of channel is 150 mm wide, not less than two rivets or bolts should be used in each connection.

3. The rivets should not be less than 16 mm in diameter for members ≤ 10 mm thick, 20 mm in diameter for members ≤ 16 mm thick, and 22 mm in diameter for members > 16 mm thick.
4. Such compression members connected by rivets/welds should not be subjected to transverse loading in a plane perpendicular to the washer-riveted or welded surface.
5. When placed back-to-back the spacing of the rivets should not exceed $12t$ or 200 mm and the longitudinal spacing between intermittent weld should not be more than $16t$, where t is thickness of the thinner section.

4.12 ENCASED COLUMN

In tall buildings, designed with skeleton as a steel structure, the columns are encased in concrete to provide flush surfaces from the architectural point of view, (Fig. 4.11). It increases the fire resistance of the column and checks corrosion of the outer columns, which otherwise have to be painted regularly. Another use of this type of column is in the basements. In the design of such a column the following specifications as laid by I.S: 800–1984 must be followed:

1. The member should be a symmetrical I-Section shape or channels back-to-back with or without cover plates.
2. The overall dimensions of the steel sections should not exceed 750×450 mm over plating where used, the larger dimension being measured parallel to web.
3. The column should be unpainted and solidly encased in ordinary dense concrete with a 20 mm aggregate and of minimum M-15 grade.
4. The minimum width of solid casing is $b_0 + 100$ mm, where b_0 is the width of steel flange of the column.
5. The surface and edges of the steel column should have a concrete cover of not less than 50 mm.
6. The casing should be reinforced with steel wires in the form of stirrups which should be at least 5 mm diameter, 150 mm c/c. These stirrups are supported by 10 mm diameter bars at the four corners.
7. Steel core encased columns should be machined accurately at splices.

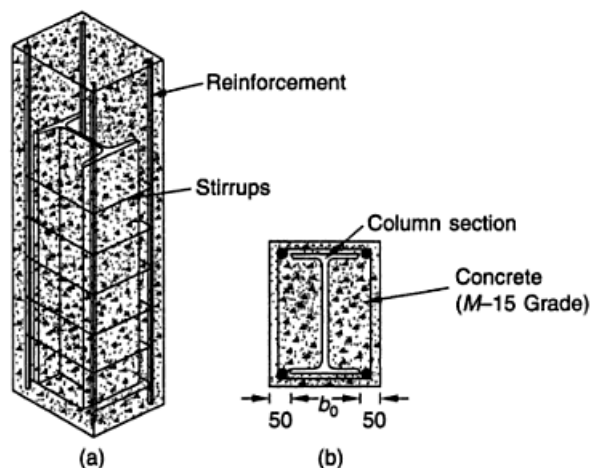

Fig. 4.11 Cased Column

Design

The steel column section is assumed to carry the entire load and is designed as a simple column but is checked in a different manner. An encased column is designed as follows:

1. Allowable working stress in the column is assumed and the cross-sectional area required for the load over it is computed.
2. A suitable section is chosen from I.S. Handbook No. 1. A section furnishing a large radius of gyration is preferred. The slenderness ratio of the column is then worked out. It should be less than 250.
3. From Table 4.4 of the text, the allowable axial stress in compression σ_{ac} is found.
4. The load carrying capacity of the column is worked out and is checked.
5. The load carrying capacity of the encased column is computed and it should not exceed two times the load permitted on an uncased column. To compute the load carrying capacity of the encased column the allowable compressive stress is calculated as follows:

The radius of gyration for the encased column about YY -axis is given by $r_{yy} = 0.2(b_0 + 100)$ mm, where b_0 = width of the steel flange in mm.

The slenderness ratio of the encased column l/r_{yy} is computed and the corresponding allowable stress in compression σ_{ac} is found from Table 4.4 of the text.

6. If a column is encased, the concrete is assumed to assist in carrying the load over its rectangular cross-section. The allowable compressive load in such a case is

$$P = A_{sc} \sigma_{sc} + A_c \sigma_c$$

where A_{sc} = cross-sectional area of steel
 A_c = cross-sectional area of concrete,
 σ_{sc} = permissible stress in steel in compression, and
 σ_c = permissible stress in concrete in compression.

But this does not apply to struts of overall dimension greater than 1000 mm \times 500 mm, the dimension of 1000 mm being measured parallel to the web or to the box sections.

4.13 ECCENTRICALLY LOADED COLUMNS

It is seldom that the axis of the load coincides with the geometrical axis of the column. The flexural stresses thus induced in the column have been given due consideration in the design formula used to calculate the allowable compressive stress. But various situations arise where the load has to be kept out of line with the column axis intentionally. Basically there can be two cases:

1. The line of action of the load is parallel to the geometrical axis of the column. Such a type of loading is called eccentric loading, e.g. load on column bracket from a gantry girder of industrial building, beam to column connections, etc. Also, the load on the column may be inclined. When resolved it gives two components, one parallel and the other perpendicular to the axis of the column. Such members are subjected to combined axial and bending stresses.
2. The line of the action of the load is perpendicular to the geometrical axis of the member. Such type of a load is called a lateral load, e.g. columns subjected to wind loads in tall buildings.

Apart from the above conditions, the compression member may be subjected to bending stresses and this should be given due consideration, e.g. struts in a truss bend due to their self weight inducing bending stresses.

Bending is very important in the case of compression members. The bending moment gives rise to thrust in the compression members which increases the lateral deflection. Therefore, loads which are initially axial become eccentric and assist bending. But in the case of tension members, the load tries to pull the member and reduces the lateral deflection of the member, if any. This is why the slenderness ratio of compression members is limited to below the limits for tension members.

Probably a more important point in the foregoing is the eccentricity of the load on the section. There is generally, however unintentional, an eccentricity of loading which causes bending with consequent additional fibre stress. Eccentricity of loading is more dangerous with a compression member than with a tension member, because in the former case an increase in the load is accompanied by an increase in buckling or displacement of the centre line of the section away from the load line, while in the latter case the centre line exhibits a greater tendency to coincide with the load line as explained above.

Eccentricity of the Load

When the load is transferred to the column from some eccentricity (the distance from the assumed point of application of the load to the centroid of column) the loads are assumed to be applied at positions as specified below:

1. *Stiffened seat* mid point of stiffening seat, (Fig. 4.12(a)) (middle of bearing length)
2. *Unstiffened seat* outer face of vertical leg of seat angle (Fig. 4.12(b))
3. *Cleats to web of beam* face of compression member (no eccentricity) (Fig. 4.12(c))

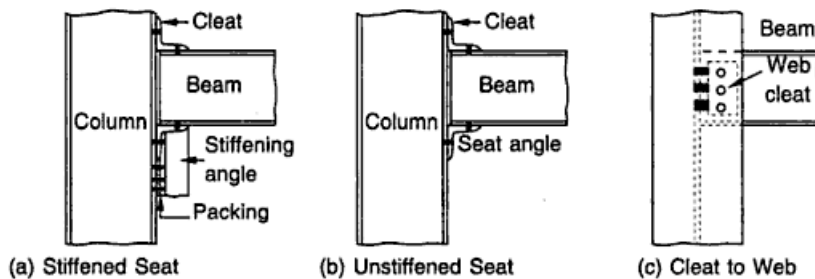

Fig. 4.12 Eccentricity of Column Loads

The eccentricity of the loads may be assumed as discussed and the bending moment may be computed by $M = Pe$, where P is the load and e the eccentricity. But for an exact analysis the following procedure should be carried out.

Let us consider a column AD , Fig. 4.13, with both ends hinged, to which a bracket plate CBE is attached. P is the load at an eccentricity of e from the centroidal axis of the section.

Let

$$AB = a$$

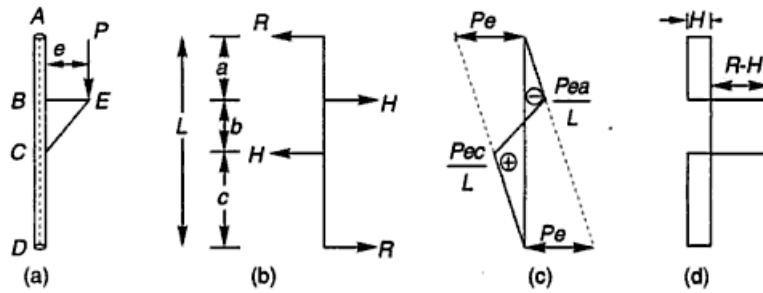

Fig. 4.13 Shear Force and Bending Moment Diagrams for a Column with Bracket

$$BC = b$$

$$CD = c$$

Consider the moment about the toe or heel (Fig. 4.13(a)), $M = Pe$. This gives rise to two equal and opposite reactions H at the ends of bracket plate, (Fig. 4.13(b)). For equilibrium,

$$Hb = Pe$$

or
$$H = \frac{Pe}{b}$$

Let R be the reaction at the two ends A and D . The bending moments at these points are zero,

or
$$RL = Hb = Pe$$

or
$$R = \frac{Pe}{L}$$

Bending moment at B is $= -Ra = -\frac{Pea}{L}$

Bending moment at $C = +Rc = +\frac{Pec}{L}$

The bending moment has a straight line variation in the portions AB , CB and CD and is plotted in Fig. 4.13(c).

The maximum value of the bending moment in the column can be when the bracket is at the top or at the bottom of the column.

$$\text{Bending moment} = R(L - b) = Pe \left(1 - \frac{b}{L}\right) \text{ at the top of bracket}$$

$$= R(L - b) = -Pe \left(1 - \frac{b}{L}\right) \text{ at the bottom of bracket}$$

Note It is observed that the maximum bending moment never reaches the value of Pe .

The shear force is plotted in Fig. 4.13(d). The shear force in various portions AB , BC , and CD of the column are R , $R - H$ and R respectively.

Similarly the values of bending moments for various end conditions of the column can be calculated and used for the design.

Combined Permissible Axial and Bending Compressive Stresses

In most of the practical situations as discussed above, columns are subjected to bending moments in addition to axial loads. For such a column section the maximum stress should not exceed the yield stress i.e.

$$\begin{aligned}\sigma_y &= \frac{P}{A} + \frac{M}{z} \\ &= \sigma_{ac, cal} + \sigma_{bc, cal}\end{aligned}\quad (4.4)$$

or

$$\frac{\sigma_{ac, cal}}{\sigma_y} + \frac{\sigma_{bc, cal}}{\sigma_y} \leq 1 \quad (4.5)$$

Since the permissible axial compressive stress depends upon the slenderness ratio, the permissible bending compressive stress depends on the lateral instability of the beam and different f.o.s. are used for loads and bending moments, Eq. (4.5) may be modified as follows.

$$\frac{\sigma_{ac, cal}}{\sigma_{ac}} + \frac{\sigma_{bc, cal}}{\sigma_{bc}} \leq 1 \quad (4.6)$$

where $\sigma_{ac, cal}$ = calculated average axial compressive stress
 σ_{ac} = permissible axial compressive stress
 σ_{bc} = permissible bending compressive stress
 $\sigma_{bc, cal}$ = maximum bending compressive stress without any consideration of additional moment due to axial load interacting with deflection

The analysis of members subjected to both bending and axial load is satisfactory so long as the axial load is not too large. The presence of axial load produces secondary moments, and unless the axial load is relatively small, these additional moments must be accounted for. This secondary moment is largest where the deflection is largest; the additional moment causes an additional deflection over and above that resulting from the transverse load. The deflections and these secondary moments can be found by second-order methods usually implemented with a computer program and are impractical for manual calculations. IS: 800 permits the use of moment amplification method. This method entails computing the maximum bending moment resulting from flexural loading by a first-order analysis, then multiplying by a moment amplification factor to account for the secondary moment. The expression for amplification factor is as follows.

$$\text{Amplification factor} = \frac{1}{1 - \frac{P}{P_E}}$$

Note The above amplification factor assumes the member braced against side sway that is, one who's ends cannot translate with respect to each other.

Euler load,
$$P_E = \frac{\pi^2 EI}{l^2} = \frac{\pi^2 EA r^2}{l^2} = \frac{\pi^2 EA}{(l/r)^2} = \frac{\pi^2 EA}{\lambda^2}$$

$$\frac{P}{P_E} = \frac{P}{\pi^2 EA/\lambda^2} = \frac{n\sigma_{ac,cal}}{\pi^2 E/\lambda^2} = \frac{n\sigma_{ac,cal}}{f_{cc}}$$

Thus the maximum bending compressive stress taking into account the additional moment due to axial load interacting with deflections

$$= \frac{\sigma_{bc,cal}}{1 - \frac{P}{P_E}} = \frac{\sigma_{bc,cal}}{1 - \frac{n\sigma_{ac,cal}}{f_{cc}}}$$

where f_{cc} = elastic critical stress in compression = $\frac{\pi^2 E}{\lambda^2}$

n = factor of safety in compression

λ = slenderness ratio = $\frac{l}{r}$

P_E = Euler load

Eq. (4.6) may be rewritten as

$$\frac{\sigma_{ac,cal}}{\sigma_{ac}} + \frac{\sigma_{bc,cal}}{\left\{1 - \frac{n\sigma_{ac,cal}}{f_{cc}}\right\} \sigma_{bc}} \leq 1 \quad (4.7)$$

Note The term within parentheses is referred to as the *amplification factor* which is based upon equal column end moments causing a single curvature deflection. It takes into account secondary moments. When f_{cc} is very large and the axial stress very small, the amplification factor is negligible. On the other hand, if f_{cc} is significant the amplification factor increases the ratio $\sigma_{bc,cal}/\sigma_{bc}$ and accounts for the additional bending stress due to secondary moment caused by an axial load.

In the derivation of Eq. (4.7) it is assumed that the column is braced against side sway and is subjected to equal end moments producing single-curvature bending (Fig. 4.14(a)). Maximum moment amplification occurs at the centre where the deflection is largest. For equal end moments, the moment is constant throughout the length of the member, so the maximum primary moment also occurs at the centre. Thus the maximum primary moments and the maximum secondary moments are additive. However, if applied end moments produce reverse-curvature bending as shown in Fig. 4.14(c), the maximum primary moment will be at one of the ends, and maximum moment amplification occurs between the ends. Depending on the value of the axial load P , the amplified moment can be either larger or smaller than the end moment.

I.S: 800-1984 recommends the above interactive formula with a factor of safety n as 1/0.6 and incorporates a reduction factor C_m , to consider the end conditions (other than equal column end moments) and side sway of the columns in frames, which should be multiplied by the amplified bending stress ratio. Thus, Eq. (4.7) can be rewritten as

$$\frac{\sigma_{ac,cal}}{\sigma_{ac}} + \frac{C_m \sigma_{bc,cal}}{\left\{1 - \frac{\sigma_{ac,cal}}{0.6 f_{cc}}\right\} \sigma_{bc}} \leq 1 \quad (4.8)$$

The interactive Eq. (4.8) can be extended to make it applicable to compression members subjected to axial load and bending moments about both the axes. Thus

$$\frac{\sigma_{ac, cal}}{\sigma_{ac}} + \frac{C_{mx} \sigma_{bcx, cal}}{\left\{1 - \frac{\sigma_{ac, cal}}{0.6 f_{ccx}}\right\} \sigma_{bcx}} + \frac{C_{my} \sigma_{bcy, cal}}{\left\{1 - \frac{\sigma_{ac, cal}}{0.6 f_{ccy}}\right\} \sigma_{bcy}} \leq 1 \quad (4.9)$$

If the additional moments due to axial loads interacting with deflections are neglected (as per I.S: 800-1984 if the ratio of $\sigma_{ac, cal}/\sigma_{ac} \leq 0.15$), Eq. (4.9) reduces to

$$\frac{\sigma_{ac, cal}}{\sigma_{ac}} + \frac{\sigma_{bcx, cal}}{\sigma_{bcx}} + \frac{\sigma_{bcy, cal}}{\sigma_{bcy}} \leq 1 \quad (4.10)$$

where

$\sigma_{bcx, cal}$ = calculated bending compressive stress due to the bending moment about major axis

σ_{bcx} = permissible bending compressive stress about major axis taking into account lateral instability

$\sigma_{bcy, cal}$ = calculated bending compressive stress due to bending moment about minor axis

σ_{bcy} = permissible bending compressive stress about minor axis

$x-x, y-y$ = major and minor axis respectively

C_m = a coefficient called reduction factor (to account for end conditions and also in certain combinations of actual bending moments where the amplification factor may overestimate the secondary effect) whose value is established by relative size and direction of the column end moments and is never more than one. It may be taken as follows for members in frames:

- (i) side sway not prevented, i.e., no bracing against sidesway buckling is provided, $C_m = 0.85$. It may be larger but not less than 0.85.
- (ii) For braced columns, side sway is prevented and not subjected to transverse load between support in the plane of bending, $C_m = 0.6 - 0.4\beta \geq 0.4$.

where

β = ratio of smaller to larger moment at the ends of the member in the plane of bending. Figure 4.14 depicts the three end conditions frequently encountered in steel buildings.

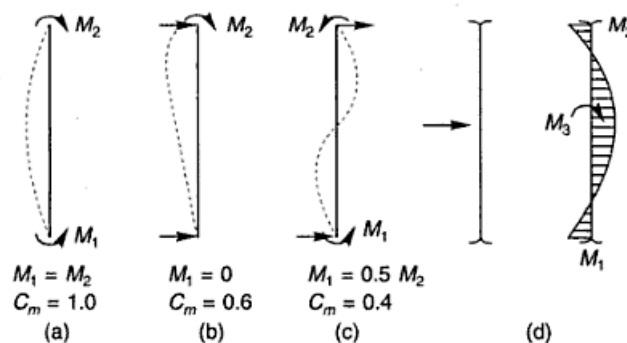

Fig. 4.14 Reduction Factors for End Braced Columns

The signs when using the ratio β are as follows:



This is in agreement with the definition of the amplification factor (i.e., single curvature bending is more critical for buckling instability than reversed curvature, and similarly the load-deflection effects will be reduced).

(iii) ends are restrained against rotation, $C_m = 0.85$

(iv) ends are not restrained against rotation, $C_m = 1.00$

When the column has transverse loading as shown in Fig. 4.14(d),

$$C_m = 1.0 + \frac{\psi \sigma_{ac, cal}}{\sigma_{ac}'}$$

where $\sigma_{ac, cal}$ = actual column stress

σ_{ac}' = Euler stress

ψ = factor depending on end restraint and transverse loading determined from Table 4.6.

Table 4.6 Values of Factor ψ for Transverse Loadings and Different End Conditions

	ψ	ψ	
	0.0	-0.2	
	-0.3	-0.4	
	-0.4	-0.6	

Design of Eccentrically Loaded Columns

Eccentrically loaded columns are subjected to direct and bending stresses. The following procedure may be adopted for its design:

1. The allowable working stress in compression is assumed and the cross-sectional area required for the axial load is computed.
2. The calculated sectional area may be increased by 50–100% to account for the eccentricity of the load or for the bending moment.
3. Suitable section is chosen from I.S. Hand Book No. 1. The slenderness ratio of the column is worked out.
4. From Table 4.4 of the text the allowable compressive stress σ_{ac} is determined for the calculated slenderness ratio.
5. The compressive stress $\sigma_{ac, cal}$ in the column is calculated by dividing the load with the sectional area provided $\sigma_{ac, cal} = P/A$.
6. The bending stress in the column is calculated by dividing the bending moment with the section modulus $\sigma_{bc, cal} = M/Z$.

7. The permissible bending stress is taken to be either $0.66f_y$, if bending is about the minor axis, or obtained from Table 7.1, of the text if bending is about the major axis. In the latter case permissible bending stresses are reduced to account for lateral instability.
8. The column section is checked for combined stresses as follows:
The ratio of $\sigma_{ac, cal}$ to σ_{ac} is worked out.

$$\text{If } \frac{\sigma_{ac, cal}}{\sigma_{ac}} \leq 0.15,$$

$$\text{then } \frac{\sigma_{ac, cal}}{\sigma_{ac}} + \frac{\sigma_{bcx, cal}}{\sigma_{bcx}} + \frac{\sigma_{bcy, cal}}{\sigma_{bcy}} \leq 1$$

This is the straight line interaction formula which does not include the influence of secondary moments resulting from axial forces, the various combination of end moments and the possible side sway effect on a beam-column. The above formula

in its revised form when $\frac{\sigma_{ac, cal}}{\sigma_{ac}} > 0.15$ is as follows.

$$\frac{\sigma_{ac, cal}}{\sigma_{ac}} + \frac{C_{mx}}{\left\{1 - \frac{\sigma_{ac, cal}}{0.60 f_{cx}}\right\}} \cdot \frac{\sigma_{bcx, cal}}{\sigma_{bcx}} + \frac{C_{my}}{\left\{1 - \frac{\sigma_{ac, cal}}{0.60 f_{cy}}\right\}} \cdot \frac{\sigma_{bcy, cal}}{\sigma_{bcy}} \leq 1$$

4.14 SPLICES

A joint when provided in the length of the column is called a splice. Splices for axially loaded compression members require little attention. If a member is loaded concentrically, no splice is required. Compression will be transmitted by direct bearing, and column sections could be rested one on top of each other and function satisfactorily. However, the load is never truly axial and the real column has to resist bending due to this eccentrically applied load. In addition to this the columns may be subjected to bending moments. Also, the bearing surfaces of the adjacent sections can never be machined to perfection. Thus the adjoining pieces must be positively connected. Column sections can be spliced in the following cases:

1. When the length of the column is more than the length of the column section available, a number of pieces are jointed to furnish the full length of the column.
2. In case of multistorey buildings, the section of the column required for the various storeys may be different, as the load goes on increasing for columns of the lower storeys.

Theoretically, a splice plate should be located at the point of contraflexure of the column. If the column ends are restrained in direction and position, this point will be at the middle of the column due to wind stresses. However, due to direct load there will be two points of contraflexure varying from the middle of column to the points above or below the middle, depending upon the amount of wind stresses.

Therefore, it is common practice to design a column of two-storey length and splice it at about 30–150 cm above the floor level. This arrangement also keeps the splice clear of beam or wind brackets.

In splicing compression members it is essential to notice the conditions of bearing surfaces of the sections being spliced, i.e. whether the ends have been faced/milled/machined for complete bearing or not. If the bearing in the two sections is achieved completely a large portion of the load passes down to the lower column directly and the splice is designed for the remaining load. However, if the exact proportion of the load transmitted by the splice plate cannot be determined accurately because of the difficulty to achieve perfect matching of the two column ends, it will be desirable to design the splice for the strength of the member. On the contrary, the tension splices are designed to transmit the full load. Following specifications are followed in the design of splices:

1. Where the ends of compression members are faced for complete bearing over the whole area, these should be spliced to hold the connected members accurately in position, and to resist any tension when bending is present.
2. Where such members are not faced for complete bearing, splices should be designed to transmit all the forces to which these are subjected.
3. Splices are designed as short columns.

The various types of splices used in compression members are shown in Figs 4.15 and 4.16. The splice system shown in Fig. 4.15(a) is used to connect two

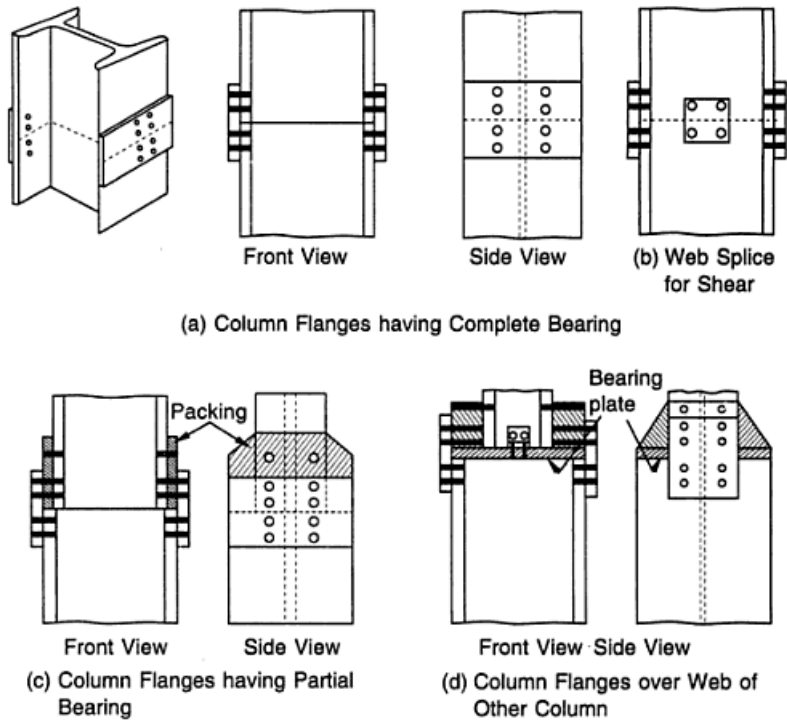

Fig. 4.15 Column Splices

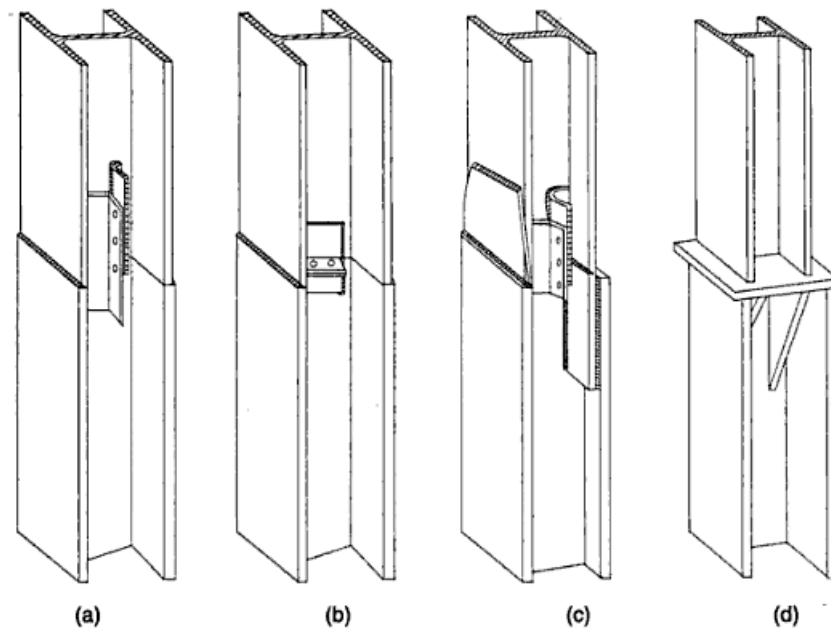

Fig. 4.16 *Welded Column Splices*

column sections having the same cross-section, i.e. the flanges of the upper storey column have full bearing over those of the lower storey column. If the flanges of the upper storey column have partial bearing over those of the lower storey column (i.e. the two column lengths do not have same cross-section) the splice shown in Fig. 4.15(c) is used. Additional packing plates will be required to ensure that the face of the upper column flanges is in the same plane as those of the lower storey column ones. If the flanges of the column of upper storey do not have any bearing over the flanges of the lower storey column (i.e., the flanges of the above storey column rest over the web of the lower storey column) then a bearing plate is provided over lower storey column. The size of the bearing plate is kept equal to the lower storey column cross-section and the next storey column is placed over the bearing plate (Fig. 4.15(d)). Suitably thick packing plates are provided on the two sides of the column of the upper storey and then splice plates are placed and connected.

When column sections are to be spliced by welding (Figs 4.16(a, b)) the ends are first milled for a square bearing surface. Then the two lower erection splice angles are shop-welded on opposite sides of the web of the heavier column section, so as to project past the end of the column. The outstanding legs of these angles are provided with holes for erection bolts to engage the outstanding legs of the other two angles that are shop welded to the upper column section. These erecting angles may be placed horizontally on the web of the column as shown in Fig. 4.16(b). Since they do not project beyond the ends of column, the possibility of damage during transit or erection is overcome. If the columns to be spliced are of different sections, Fig. 4.16(c), the splice plates are first shop-welded (fillet) to the inside face of the flange of the lower column. They are milled with the lower column

section. As an alternate to this, splice plates with their lower edges prepared for welding are shop fillet welded to the outside face of the flanges on the upper column. Sometimes when new steel is erected adjacent to an old structure, a combination of this procedure may be used.

If the lower storey column is much deeper than the upper storey column section, stiffeners can be welded as shown in Fig. 4.16(d). These stiffeners will be placed directly below the flanges of the upper column which reduces the thickness of the bearing plate. If the section where splicing is done is subjected to shear force, then the web of the column is spliced with a pair of splice plates (one on each side of the web) as shown in Fig. 4.15(b).

Design

The first step is to ascertain the nature of the loads to which the splice is subjected. They are the axial compressive load, bending moment and occasionally shear.

1. For axial compressive load the splice plates are provided on the flanges of the two column sections to be spliced.

If the column has machined ends, the splice is designed only to keep the columns in position and to carry tension due to the bending moment to which it may be subjected. The splice plate and the connections should be designed to carry 50% of the axial load and tension (if any due to bending moment). If the ends of the columns are not machined, the splice and connections are designed to resist the total axial load and any tension, if present due to the bending moment.

The load P_1 for the design of splice and connection due to axial load P on the column will be $P/4$ (machined ends) and $P/2$ (non machined ends).

The load due to bending moment, $P_2 = \frac{M}{\text{lever arm}}$

where the lever arm is the *c/c* distance of the two splice plates and P_2 is the load due to the bending moment.

2. Splice plates are assumed to act as short columns with zero slenderness ratio. So these plates will be subjected to full allowable compressive stress ($0.6 f_y$).
3. The cross-sectional area of the splice plate is calculated by dividing the load coming over the splice by the allowable compressive stress.
4. The width of the splice plate is usually kept equal to the width of the column flange. The thickness of the splice plate is found by dividing the cross-sectional area of the splice plate by the width of the splice plate provided.
5. Nominal diameter of the rivet for connections is assumed and the rivet value is computed. The number of rivets are found by dividing the total load coming on splice by the rivet value.
6. In case a bearing plate is to be designed between two column sections, the length and width of the plate are kept equal to the size of lower storey column and the thickness is computed by equating the moment due to the load to the moment of resistance of plate section.

Notes

1. If the joint is subjected to a bending moment along with the axial load, the splice plate is provided on flanges. The total load to which splice and connections are designed will

- be sum of the axial load and the load due to the bending moment ($P_1 + P_2$). Rivets are also checked in tension.
- When shear force acts in addition to gravity loads, a splice plate is provided on the web (as the web takes the maximum shear stress).
 - The splices should, as far as possible, be so placed that the centroidal axis of the splice coincides with the centroidal axis of the member jointed. This is done to avoid any eccentricity.
 - If packings are provided between the splice plate and the column flange additional rivets as per I.S. specifications are provided on the packings.

Solved Examples

Example 4.1 Calculate the value of the least radius of gyration for a compound column consisting of I.S.H.B. 250 @ 536.6 N/m with one cover plate 300 mm × 20 mm on each flange.

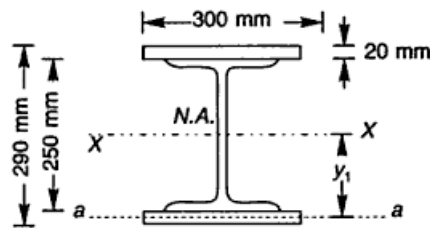

Fig. Ex. 4.1

Solution Refer to Fig. Ex. 4.1

From I.S. Handbook No. 1, I_{xx} of I.S.H.B. 250 = $7983.9 \times 10^4 \text{ mm}^4$ and $A = 6971 \text{ mm}^2$

$$\begin{aligned}
 I_{xx} \text{ for plates} &= 2[I_{aa} + A_p y_1^2] \\
 &= 2 \left[\frac{300 \times 20^3}{12} + 300 \times 20 \times (125 + 10)^2 \right] \\
 &= 21910 \times 10^4 \text{ mm}^4
 \end{aligned}$$

$$\text{Total } I_{xx} = 7983.9 \times 10^4 + 21910 \times 10^4 = 29893.9 \times 10^4 \text{ mm}^4$$

$$\text{Area of the built up section} = (6971 + 2 \times 300 \times 20) = 18971 \text{ mm}^2$$

$$r_{xx} = \sqrt{\frac{I_{xx}}{A}} = \sqrt{\frac{29,893.9 \times 10^4}{18,971}} = 125.52 \text{ mm}$$

$$I_{yy} \text{ of I.S.H.B. 250 @ 536.6 N/m} = 2011.7 \times 10^4 \text{ mm}^4$$

$$I_{yy} \text{ of plates} = 2 \times \frac{20 \times (300)^3}{12} = 9000 \times 10^4 \text{ mm}^4$$

$$\text{Total } I_{yy} = 2011.7 \times 10^4 + 9000 \times 10^4 = 11,011.7 \times 10^4 \text{ mm}^4$$

$$r_{yy} = \sqrt{\frac{I_{yy}}{A}} = \sqrt{\frac{11,011.7 \times 10^4}{18971}} = 76.187 \text{ mm}$$

Example 4.2 An I.S.A. 100 mm × 100 mm × 6 mm ($f_y = 250 \text{ N/mm}^2$) is used as a strut in a truss. The length of the strut between the intersections at each end is 3.0 m. Calculate the strength of the strut if,

- (a) it is connected by two rivets at each end
- (b) it is connected by one rivet at each end
- (c) it is welded at each end.

Solution From I.S. Handbook No. 1, the minimum radius of gyration of I.S.A. 100 × 100 × 6 mm, $r_{yy} = 19.5 \text{ mm}$, $A = 1167 \text{ mm}^2$

(a) $L = 3.0 \text{ m}$

From Table 4.2 of the text, the effective length

$$l = 0.85 \times 3000 = 2550 \text{ mm}$$

$$\frac{l}{r} = \frac{2550}{19.5} = 130.769 < 350$$

From Table 4.4. of the text (Table 5.1 of I.S: 800–1984),

$$\text{for } l/r = 130.769 \text{ and } f_y = 250 \text{ N/mm}^2; \quad \sigma_{ac} = 56.538 \text{ N/mm}^2$$

$$\text{Allowable working compressive stress} = 56.538 \text{ N/mm}^2$$

$$\text{Strength of the strut} = 56.538 \times 1167$$

$$= 65,980.54 \text{ N} = 65.98 \text{ kN}$$

(b) $L = 3.0 \text{ m}$

From Table 4.2 of the text, the effective length,

$$l = 1.0 \times 3000 = 3000 \text{ mm}$$

$$\frac{l}{r} = \frac{3000}{19.5} = 153.846 < 180$$

From Table 4.4 of the text (Table 5.1 of I.S: 800–1984),

$$\text{for } l/r = 153.846 \text{ and } f_y = 250 \text{ N/mm}^2; \quad \sigma_{ac} = 43.46 \text{ N/mm}^2$$

$$\text{Allowable working compressive stress} = 0.80 \sigma_{ac} = 0.80 \times 43.46$$

$$= 34.76 \text{ N/mm}^2$$

$$\text{Strength of the strut} = 34.76 \times 1167$$

$$= 40,564.92 \text{ N} = 40.564 \text{ kN}$$

(c) When the strut is welded at each end, the specifications as laid by the I.S. code are similar to case (a) and, therefore, the strength of the strut will be 65.98 kN.

Example 4.3 Calculate the strength of a discontinuous strut of length 3.2 m. The strut consists of two unequal angles 100 mm × 75 mm × 8 mm ($f_y = 250 \text{ N/mm}^2$), with long legs connected and placed:

- (a) on the opposite side of a gusset plate (Fig. Ex. 4.3(a))
- (b) on the same side of a gusset plate (Fig. Ex. 4.3(b))

Note The strut is tack riveted and is connected to a 10 mm gusset plate.

Solution From I.S. Handbook No. 1, the properties of two angles back-to-back and spaced 10 mm apart are:

$$A = 2672 \text{ mm}^2$$

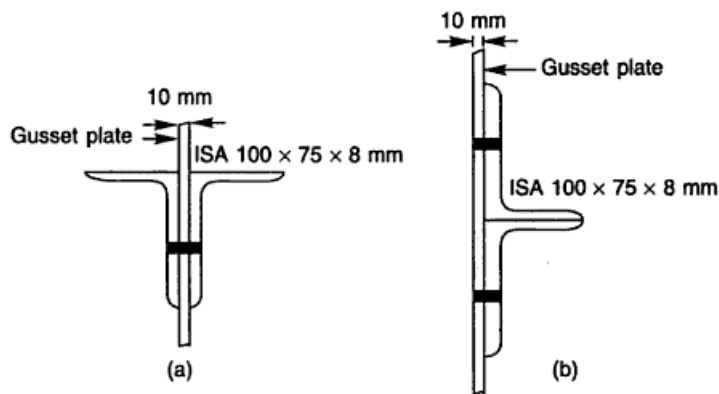
Fig. Ex. 4.3

(a) Angles placed on opposite side of gusset plate:

$$r_{xx} = 31.4 \text{ mm}, r_{yy} = 32.2 \text{ mm}$$

Minimum radius of gyration, $r = 31.4 \text{ mm}$

$$l = 0.85L$$

$$= 0.85 \times 3.2 \times 10^3 = 2720 \text{ mm}$$

$$\frac{l}{r} = \frac{2720}{31.4} = 86.624$$

From Table 4.4 of the text (Table 5.1 of I.S: 800-1984),

for $l/r = 86.624$ and $f_y = 250 \text{ N/mm}^2$; $\sigma_{ac} = 93.7136 \text{ N/mm}^2$

$$\begin{aligned} \text{Strength of the strut} &= 93.7136 \times 2672 \\ &= 250,402.74 \text{ N} = 250.40 \text{ kN} \end{aligned}$$

(b) Angles placed on same side of gusset plate:

$$r_{xx} = 21.8 \text{ mm}, r_{yy} = 44.1 \text{ mm}$$

$$l = L$$

$$= 3.2 \times 10^3 = 3200 \text{ mm}$$

$$\frac{l}{r} = \frac{3200}{21.8} = 146.78$$

From Table 4.4 of the text (Table 5.1 of I.S: 800-1984),

for $l/r = 146.78$ and $f_y = 250 \text{ N/mm}^2$; $\sigma_{ac} = 46.93 \text{ N/mm}^2$

$$\text{Allowable working compressive stress} = 0.80 \times 46.93 = 37.54 \text{ N/mm}^2$$

$$\begin{aligned} \text{Strength of the strut} &= 37.54 \times 2672 \\ &= 100,317.56 \text{ N} = 100.317 \text{ kN} \end{aligned}$$

Example 4.4 Calculate the safe axial load for a stanchion I.S.H.B. 350 @ 710.2 N/m, 3.5 m high. It is to be used as an uncased column in a single storey building. The column is restrained in direction and position at both the ends. $f_y = 250 \text{ N/mm}^2$

Solution

$$l = 0.65L$$

$$= 0.65 \times 3.5 \times 1000 = 2275 \text{ mm}$$

From I.S. Handbook No. 1, the relevant properties of I.S.H.B. 350 @ N/m are,

$$r_{xx} = 146.5 \text{ mm}, r_{yy} = 52.2 \text{ mm}, A = 9221 \text{ mm}^2$$

Minimum radius of gyration, $r = 52.2 \text{ mm}$

$$\frac{l}{r} = \frac{2275}{52.2} = 43.58$$

For $\frac{l}{r} = 43.58$, and $f_y = 250 \text{ N/mm}^2$,

$$\sigma_{ac} = 136.49 \text{ N/mm}^2$$

$$\therefore \text{Safe axial load} = 136.49 \times 9221$$

$$= 1,258,574.29 \text{ N} = 1258.57 \text{ kN}$$

Example 4.5 Calculate the safe load over a compression member of unsupported length of 4.8 m. The member is to be used in a transmission line tower and is as shown in Fig. Ex. 4.5. The ends are held in position but not restrained in direction. The overall section of the member is 180 mm \times 180 mm. Assume $f_y = 250 \text{ N/mm}^2$.

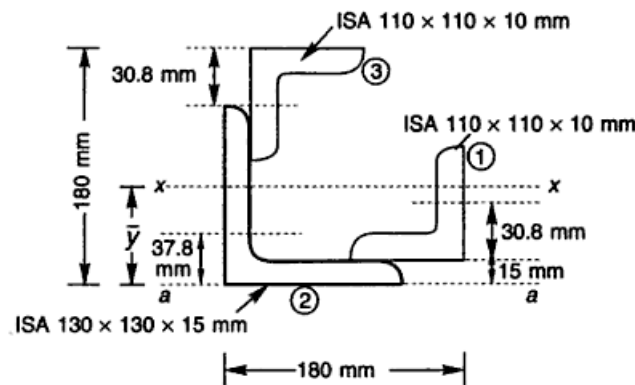

Fig. Ex. 4.5

Solution The relevant properties of the angle sections used from I.S. Handbook No. 1 are as follows:

I.S.A. 110 mm \times 110 mm \times 10 mm

$$A = 2106 \text{ mm}^2, I_{xx} = I_{yy} = 238.4 \times 10^4 \text{ mm}^4, r_{xx} = r_{yy} = 33.6 \text{ mm}, c_{xx} = c_{yy} = 30.8 \text{ mm}$$

I.S.A. 130 mm \times 130 mm \times 15 mm

$$A = 3681 \text{ mm}^2, I_{xx} = I_{yy} = 574.6 \times 10^4 \text{ mm}^4, r_{xx} = r_{yy} = 39.5 \text{ mm}, c_{xx} = c_{yy} = 37.8 \text{ mm}$$

Let the distance of the centroidal axis xx from the face aa of the section be \bar{y} .

Taking the moment of the area about the axis aa ,

$$(2106 + 3681 + 2106) \bar{y} = 2106(30.8 + 15) + 3681(37.8)$$

$$+ 2106(180 - 30.8)$$

$$\text{or} \quad 7893 \bar{y} = 96,454.8 + 139,141.8 + 314,215.2$$

$$\text{or} \quad \bar{y} = \frac{549,811.8}{7893} = 69.658 \text{ mm}$$

Moment of inertia about xx -axis (I_{xx}) can be found as follows:

$$I_{xx} = I_{xx1} + I_{xx2} + I_{xx3}$$

Moment of inertia of angle section 1 about centroidal axis xx ,

$$\begin{aligned} I_{xx1} &= 238.4 \times 10^4 + 2106 \times (69.658 - 30.8 - 15)^2 \\ &= 358.27 \times 10^4 \text{ mm}^4 \end{aligned}$$

Moment of inertia of angle section 2 about centroidal axis xx ,

$$\begin{aligned} I_{xx2} &= 574.6 \times 10^4 + 3681 \times (69.658 - 37.8)^2 \\ &= 948.19 \times 10^4 \text{ mm}^4 \end{aligned}$$

Moment of inertia of angle section 3 about centroidal axis xx ,

$$\begin{aligned} I_{xx3} &= 238.4 \times 10^4 + 2106(180 - 69.658 - 30.8)^2 \\ &= 1570.85 \times 10^4 \text{ mm}^4 \end{aligned}$$

$$\begin{aligned} I_{xx} &= (358.27 + 948.19 + 1570.85) \times 10^4 \\ &= 2877.31 \times 10^4 \text{ mm}^4 \end{aligned}$$

The two angle sections (1) and (3) are placed in such a way that the moment of inertia about yy -axis will be same as that about the xx -axis. Hence r_{xx} and r_{yy} will be equal.

$$\text{Minimum radius of gyration, } r = r_{xx} = \sqrt{\frac{I_{xx}}{A}}$$

$$= \sqrt{\frac{2877.31 \times 10^4}{2106 + 3681 + 2106}} = 60.37 \text{ mm}$$

$$l = 4800 \text{ mm}$$

$$\frac{l}{r} = \frac{4800}{60.37} = 79.5$$

For $\frac{l}{r} = 79.5$, and $f_y = 250 \text{ MPa}$,

$$\begin{aligned} \sigma_{oc} &= 102.04 \text{ N/mm}^2 \\ \text{Safe load} &= 102.04 \times 7893 \times 10^{-3} \\ &= 805.44 \text{ kN} \end{aligned}$$

Example 4.6 Determine the allowable compressive load which the member shown in the Fig. Ex. 4.6 can support, if the member is of 5.5 m effective length. Assume $f_y = 250 \text{ N/mm}^2$.

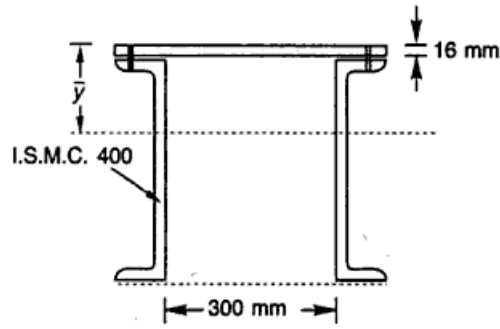

Fig. Ex. 4.6

Solution From I.S. Handbook No. 1, the relevant properties of ISMC 400 @ 484.6 N/m are,

$$A = 6293 \text{ mm}^2, B = 100 \text{ mm}, T = 15.3 \text{ mm}, t = 8.6 \text{ mm}, r_{xx} = 154.8 \text{ mm}, g = 60 \text{ mm}, I_{xx} = 15,082.8 \times 10^4 \text{ mm}^4, I_{yy} = 504.8 \times 10^4 \text{ mm}^4, C_{yy} = 24.2 \text{ mm}$$

$$\text{Area of channel sections} = 2 \times 6293 = 12,586 \text{ mm}^2$$

$$\text{Area of plate section} = (300 + 2 \times 100) \times 16 = 8000 \text{ mm}^2$$

$$\text{Total area provided} = 12,586 + 8000 = 20,586 \text{ mm}^2$$

Let the distance of neutral axis from top be \bar{y} .

$$\bar{y} = \frac{2 \times 6293 \times \left(\frac{400}{2} + 16 \right) + 8000 \times \frac{16}{2}}{20,586}$$

$$= 135.168 \text{ mm}$$

$$I_{xx} = 2[15,082.8 \times 10^4 + 6293 \times (216 - 135.168)^2]$$

$$+ \frac{500 \times 16^3}{12} + 500 \times 16 \times (135.168 - 8)^2$$

$$= 51,342.82 \times 10^4 \text{ mm}^4$$

$$I_{yy} = 2 \times 504.8 \times 10^4 + 16 \times \frac{500^3}{12} + 2 \times 6293 \times (150 + 24.2)^2$$

$$= 55869.22 \times 10^4 \text{ mm}^4$$

As I_{xx} is less than I_{yy} , the minimum radius of gyration will be r_{xx} .

$$\text{Minimum radius of gyration, } r = \sqrt{\frac{51342.82 \times 10^4}{20,586}} = 157.92 \text{ mm}$$

$$\frac{l}{r} = \frac{5.5 \times 10^3}{157.92} = 34.82$$

From I.S.: 800-1984, the allowable compressive stress for $l/r = 34.82$ and $f_y = 250 \text{ N/mm}^2$ is

$$\sigma_{ac} = 142.10 \text{ N/mm}^2$$

$$\text{Allowable safe load} = 142.10 \times 20586$$

$$= 2920356 \text{ N} = 2920.356 \text{ kN}$$

Example 4.7 Design a single angle discontinuous strut to carry a load of 47 kN. The length of the strut is 3.0 m between intersections. The strut is connected to 12 mm thick gusset plate with (a) 24 mm ϕ power driven rivet(s) (b) 20 mm ϕ hand driven rivet (s).

Solution Let us assume allowable compressive stress of 60 MPa.

$$\begin{aligned}\text{Cross-sectional area required} &= \frac{47 \times 10^3}{60} \\ &= 783.33 \text{ mm}^2\end{aligned}$$

(a) *Strut connected by 24 mm ϕ rivet(s)*

$$\phi = 24 \text{ mm}$$

$$d = 24 + 1.5 = 25.5 \text{ mm}$$

$$\text{Strength of rivet in single shear} = \frac{\pi}{4} d^2 \tau_{vf}$$

$$= \frac{\pi}{4} 25.5^2 \times 100$$

$$= 51000 \text{ N} = 51 \text{ kN}$$

$$\text{Strength of rivet in bearing} = d t \sigma_{pf}$$

$$= 25.5 \times 8 \times 300 = 61200 \text{ N} = 61.2 \text{ kN}$$

$$\text{Hence, rivet value, } R_v = 51 \text{ kN}$$

$$\text{Number of rivets required, } N = \frac{47}{51} = 0.92 = 1$$

Let us provide 24 mm ϕ power driven one rivet at each end of the strut for making the connection.

From I.S. Handbook No. 1 select an angle section giving a value close to the required area (783.33 mm²). Provide a trial section I.S.A. equal angle 60 \times 60 \times 8 mm (weight 68.7 N/m).

$$A = 896 \text{ mm}^2$$

$$\text{Minimum radius of gyration, } r = r_{vw} = 11.5 \text{ mm}$$

$$l = 1.0 \times 3 \times 10^3 = 3000 \text{ mm}$$

$$\frac{l}{r} = \frac{3000}{11.5} = 260.86 > 180 \quad \text{not safe}$$

Since the section is not safe for the slenderness ratio limit, calculations for its load carrying capacity are meaningless and are, therefore, not made.

Select another trial section I.S.A. 100 \times 100 \times 8 mm (weight = 118.7 N/m).

$$A = 1539 \text{ mm}^2$$

$$\text{Minimum radius of gyration, } r = 19.5 \text{ mm}$$

$$\frac{l}{r} = \frac{3000}{19.5} = 153.84 < 180$$

For $\frac{l}{r} = 153.84$ and $f_y = 250$ MPa,

$$\sigma_{ac} = 43.46 \text{ N/mm}^2$$

$$\text{Allowable compressive stress} = 0.8 \times 43.46 = 34.76 \text{ N/mm}^2$$

$$\begin{aligned} \text{Load carrying capacity} &= 34.76 \times 1539 \\ &= 53509.8 \text{ N} = 53.50 \text{ kN} \\ &> \text{load over strut} \end{aligned}$$

(b) *Strut connected by 20 mm ϕ rivet(s)*

$$\phi = 20 \text{ mm}$$

$$d = 20 + 1.5 = 21.5 \text{ mm}$$

Let us provide 20 mm ϕ hand driven 2 rivets at each end of the strut for making connection.

$$\begin{aligned} \text{Strength of rivet in single shear} &= \frac{\pi}{4} d^2 \tau_{vf} \\ &= \frac{\pi}{4} \times 21.5^2 \times 80 = 29044 \text{ N} = 29.04 \text{ kN} \end{aligned}$$

$$\begin{aligned} \text{Strength of rivet in bearing} &= d t \sigma_{pf} \\ &= 21.5 \times 10 \times 250 = 53750 \text{ N} = 53.75 \text{ kN} \end{aligned}$$

$$\text{Hence, rivet value, } R_v = 29.04 \text{ kN}$$

$$\text{Number of rivets required, } N = \frac{47}{29.04} = 1.618 \approx 2$$

Select a trial section $80 \times 80 \times 10$ mm.

$$A = 1505 \text{ mm}^2$$

Minimum radius of gyration, $r = 15.5$ mm

$$l = 0.85 \times 3000 = 2550 \text{ mm}$$

$$\frac{l}{r} = \frac{2550}{15.5} = 164.516 < 350$$

For $\frac{l}{r} = 164.516$ and $f_y = 250$ MPa,

$$\sigma_{ac} = 39.1936 \text{ N/mm}^2$$

$$\begin{aligned} \text{Load carrying capacity} &= 39.1936 \times 1505 \\ &= 58,986.36 \text{ N} = 58.98 \text{ kN} \\ &> \text{load over the strut} \end{aligned}$$

The above section is oversafe, therefore, let us select another trial section. Try I.S.A. $100 \times 75 \times 8$ mm (weight 103 N/m).

$$A = 1336 \text{ mm}^2$$

Minimum radius of gyration, $r = 15.9$ mm

$$\frac{l}{r} = \frac{2550}{15.9} = 160.37$$

For $\frac{l}{r} = 160.37$ and $f_y = 250$ MPa,

$$\begin{aligned}\sigma_{ac} &= 40.852 \text{ N/mm}^2 \\ \text{Load carrying capacity} &= 40.852 \times 1336 \\ &= 54578.272 \text{ N} = 54.57 \text{ kN} \\ &> \text{load over the strut}\end{aligned}$$

It should be noted that by merely increasing one rivet in the connection, considerable economy has been achieved. The weight of section, when two rivets are used for connection reduces from 118.7 N/m to 103 N/m.

Example 4.8 Design a double angle discontinuous strut to carry a load of 90 kN. The length of the strut is 3.0 m between intersections. The two angles are placed back to back (with long legs connected) and are tack riveted.

- (a) Angles are placed on opposite sides of 12 mm gusset plate.
 (b) Angles are placed on same side of 12 mm gusset plate.

Solution Let us assume allowable compressive stress of 60 MPa.

$$\text{Cross-sectional area required} = \frac{90 \times 10^3}{60} = 1500 \text{ mm}^2$$

(a) Angles placed on opposite sides of gusset plate From I.S. Handbook No. 1 select 2 I.S.A. 65 × 65 × 8 mm (weight = 151 N/m).

$$\text{Area provided} = 1952 \text{ mm}^2$$

Minimum radius of gyration, $r = r_{xx} = 19.6$ mm

$$\begin{aligned}l &= 0.85L \\ &= 0.85 \times 3000 = 2550 \text{ mm} \\ \frac{l}{r} &= \frac{2550}{19.6} = 130.10 < 350\end{aligned}$$

For $\frac{l}{r} = 130.10$ and $f_y = 250$ MPa,

$$\begin{aligned}\sigma_{ac} &= 56.94 \text{ N/mm}^2 \\ \text{Safe load} &= 56.94 \times 1952 \\ &= 111,146.88 \text{ N} = 111.146 \text{ kN} \\ &> \text{load over the strut}\end{aligned}$$

The designer may now try to economise the section.

Try a section having a greater radius of gyration and less weight/m run. Select 2 I.S.A. 70 × 70 × 6 mm (weight = 123.6 N/m).

$$A = 1612 \text{ mm}^2$$

Minimum radius of gyration, $r = 21.4$ mm

$$\frac{l}{r} = \frac{2550}{21.4} = 119.158 < 350$$

For $\frac{l}{r} = 119.158$ and $f_y = 250$ MPa,

$$\sigma_{ac} = 64.67 \text{ N/mm}^2$$

$$\text{Safe load} = 64.67 \times 1612$$

$$= 104,248.04 \text{ N} = 104.248 \text{ kN}$$

> load over the strut

Provide 2 I.S.A. 70 × 70 × 6 mm on opposite side of the gusset plate (Fig. Ex. 4.8(a)). From the above trial it is observed that the weight of the section is reduced from 151 N/m to 123.6 N/m and the section is still oversafe. Therefore, if desired another section may be tried to bring further economy.

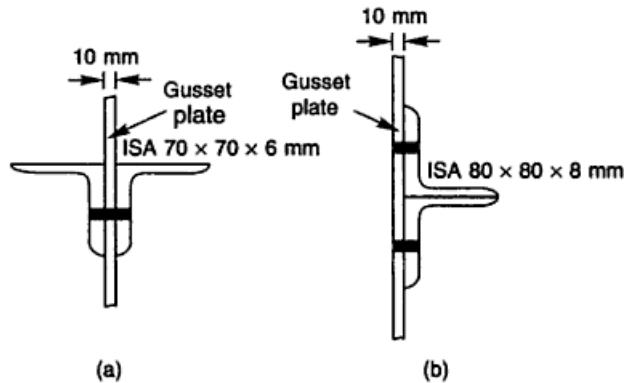

Fig. Ex. 4.8

(b) Angles placed on same side of gusset plate Select 2 I.S.A. 65 × 65 × 8 mm

$$A = 1952 \text{ mm}^2$$

Minimum radius of gyration, $r = 19.6 \text{ mm}$

$$l = 3000 \text{ mm}$$

$$\frac{l}{r} = \frac{3000}{19.6} = 153.06 < 350$$

For $\frac{l}{r} = 153.06$ and $f_y = 250 \text{ MPa}$,

$$\sigma_{ac} = 43.776 \text{ N/mm}^2$$

Allowable working compressive stress = $0.8 \times 43.776 = 35.02 \text{ N/mm}^2$

$$\text{Safe load} = 35.02 \times 1952$$

$$= 68,359 \text{ N} = 68.359 \text{ kN}$$

< load over the strut

The design is not satisfactory.

Select 2 I.S.A. 80 × 80 × 6 mm (weight = 143.2 N/m).

$$A = 1858 \text{ mm}^2$$

Minimum radius of gyration, $r = r_{xx} = 24.6 \text{ mm}$

$$\frac{l}{r} = \frac{3000}{24.6} = 121.95 < 350$$

$$\begin{aligned}\sigma_{ac} &= 64.67 \text{ N/mm}^2 \\ \text{Safe load} &= 64.67 \times 1612 \\ &= 104,248.04 \text{ N} = 104.248 \text{ kN} \\ &> \text{load over the strut}\end{aligned}$$

Provide 2 I.S.A. 70 × 70 × 6 mm on opposite side of the gusset plate (Fig. Ex. 4.8(a)). From the above trial it is observed that the weight of the section is reduced from 151 N/m to 123.6 N/m and the section is still oversafe. Therefore, if desired another section may be tried to bring further economy.

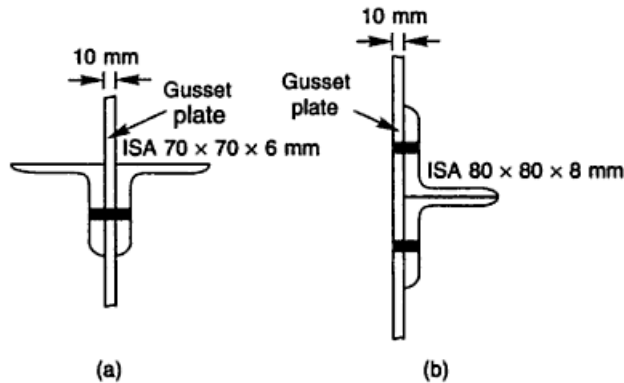

Fig. Ex. 4.8

(b) Angles placed on same side of gusset plate Select 2 I.S.A. 65 × 65 × 8 mm

$$\begin{aligned}A &= 1952 \text{ mm}^2 \\ \text{Minimum radius of gyration, } r &= 19.6 \text{ mm} \\ l &= 3000 \text{ mm} \\ \frac{l}{r} &= \frac{3000}{19.6} = 153.06 < 350\end{aligned}$$

For $\frac{l}{r} = 153.06$ and $f_y = 250 \text{ MPa}$,

$$\begin{aligned}\sigma_{ac} &= 43.776 \text{ N/mm}^2 \\ \text{Allowable working compressive stress} &= 0.8 \times 43.776 = 35.02 \text{ N/mm}^2 \\ \text{Safe load} &= 35.02 \times 1952 \\ &= 68,359 \text{ N} = 68.359 \text{ kN} \\ &< \text{load over the strut}\end{aligned}$$

The design is not satisfactory.

Select 2 I.S.A. 80 × 80 × 6 mm (weight = 143.2 N/m).

$$\begin{aligned}A &= 1858 \text{ mm}^2 \\ \text{Minimum radius of gyration, } r = r_{xx} &= 24.6 \text{ mm} \\ \frac{l}{r} &= \frac{3000}{24.6} = 121.95 < 350\end{aligned}$$

For $\frac{l}{r} = 121.95$ and $f_y = 250$ MPa,

$$\sigma_{ac} = 62.635 \text{ N/mm}^2$$

$$\begin{aligned} \text{Allowable working compressive stress} &= 0.8 \times 62.635 \text{ N/mm}^2 \\ &= 50.108 \text{ N/mm}^2 \end{aligned}$$

$$\begin{aligned} \text{Safe load} &= 50.108 \times 1858 \\ &= 93,100.664 \text{ N} = 93.100 \text{ kN} \\ &> \text{load over strut} \end{aligned}$$

This design is safe and economical and, therefore, satisfactory. Provide 2 I.S.A. 80 × 80 × 6 mm on the same side of gusset plate (Fig. Ex. 4.8(b)).

Note From this example it can be concluded that it is economical to provide two angles on the opposite side of the gusset plate.

Example 4.9 Design a column to support an axial load of 700 kN. The column has an effective length of 7 m with respect to the x-axis and 5.0 m with respect to the y-axis. $f_y = 250$ N/mm²

Solution Let us assume the allowable axial compressive stress as 85 N/mm².

$$A = \frac{700 \times 10^3}{85} = 8235.29 \text{ mm}^2$$

From I.S. Handbook No. 1 try I.S.H.B. 350 @ 661.2 N/m. The relevant properties of the section are,

$$\begin{aligned} A &= 8591 \text{ mm}^2 \\ r_{xx} &= 149.3 \text{ mm}, r_{yy} = 53.4 \text{ mm} \\ \frac{l_x}{r_{xx}} &= \frac{7 \times 10^3}{149.3} = 46.885 < 180 \end{aligned}$$

which is safe.

$$\frac{l_y}{r_{yy}} = \frac{5 \times 10^3}{53.4} = 93.63 < 180$$

which is safe.

From Table 4.4 of the text for $l_x/r_{xx} = 46.885$ and $f_y = 250$ MPa

$$\sigma_{ac1} = 134.1805 \text{ N/mm}^2$$

$$\begin{aligned} \text{Load carrying capacity} &= 134.1805 \times 8591 \\ &= 1152.744 \text{ kN} > 700 \text{ kN} \end{aligned}$$

which is all right.

For $l_y/r_{yy} = 93.63$, and $f_y = 250$ MPa,

$$\sigma_{ac2} = 86.37 \text{ N/mm}^2$$

$$\begin{aligned} \text{Load carrying capacity} &= 86.37 \times 8591 \\ &= 742004.67 \text{ N} = 742 \text{ kN} > 700 \text{ kN} \end{aligned}$$

which is safe.

Hence, provide I.S.H.B. 350 @ 661.2 N/m.

Example 4.10 Design a stanchion 3.5 m long in a building subjected to an axial load of 350 kN. Both the ends of the stanchion are effectively restrained in direction and position. Assume $f_y = 250$ MPa.

Solution Assume allowable axial compressive stress = 85 N/mm²

$$\text{Cross-sectional area required} = \frac{350 \times 10^3}{85} = 4117.64 \text{ mm}^2$$

From I.S. Handbook No. 1 select I.S.H.B. 150 @ 339.4 N/m.

The relevant properties of the section are,

$$A = 4408 \text{ mm}^2$$

$$\text{Minimum radius of gyration, } r = r_{yy} = 33.5 \text{ mm}$$

$$l = 0.65 L$$

$$= 0.65 \times 3.5 \times 10^3 = 2275 \text{ mm}$$

$$\frac{l}{r} = \frac{2275}{33.5} = 67.91 < 180$$

which is as it should be.

$$\text{For } \frac{l}{r} = 67.91 \text{ and } f_y = 250 \text{ N/mm}^2,$$

$$\sigma_{ac} = 114.09 \text{ N/mm}^2$$

$$\text{Safe load carrying capacity} = 114.09 \times 4408$$

$$= 502,908.7 \text{ N} = 502.90 \text{ kN} > 350 \text{ kN}$$

This section is oversafe, therefore let us try another one. Select I.S.H.B. 150 @ 265.9 N/m. The relevant properties are,

$$A = 3448 \text{ mm}^2$$

$$\text{Minimum radius of gyration, } r = r_{yy} = 35.4 \text{ mm}$$

$$\frac{l}{r} = \frac{2275}{35.4} = 64.265 < 180$$

$$\text{For } \frac{l}{r} = 64.265 \text{ and } f_y = 250 \text{ MPa},$$

$$\sigma_{ac} = 117.735 \text{ N/mm}^2$$

$$\text{Safe load carrying capacity} = 117.735 \times 3448 \times 10^{-3}$$

$$= 405.950 \text{ kN}$$

$$> 350 \text{ kN}$$

which is all right.

Hence, provide I.S.H.B. 150 @ 265.9 N/m.

Example 4.11 An 8.0 m long column of an industrial building supports a bracket 1.5 m × 1.0 m and 1.8 m below the end supporting truss as shown in Fig. Ex. 4.11. The reaction from the truss is 140 kN. The bracket supports a beam transmitting an end reaction of 75 kN. The eccentricity of the end reaction from the column axis is 1.00 m. The ends of the column are restrained in position but not in the direction. Design the column.

Solution

$$l = L$$

$$= 8.0 \text{ m} = 8 \times 10^3 \text{ mm}$$

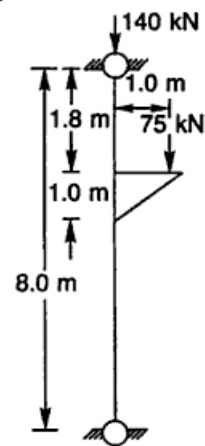

Fig. Ex. 4.11

$$\begin{aligned}
 e &= 1 \times 10^3 \text{ mm} \\
 a &= 1.8 \times 10^3 \text{ mm} \\
 c &= (8 - 1.8 - 1) \times 10^3 = 5.2 \times 10^3 \text{ mm}
 \end{aligned}$$

$$\begin{aligned}
 \text{Maximum negative bending moment} &= \frac{Pea}{l} \\
 &= \frac{75 \times 10^3 \times 1 \times 10^3 \times 1.8 \times 10^3}{8 \times 10^3} \\
 &= 16,875 \times 10^3 \text{ Nmm}
 \end{aligned}$$

$$\begin{aligned}
 \text{Maximum positive bending moment} &= \frac{Pec}{l} \\
 &= \frac{75 \times 10^3 \times 1 \times 10^3 \times 5.2 \times 10^3}{8 \times 10^3} \\
 &= 48,750 \times 10^3 \text{ Nmm}
 \end{aligned}$$

Hence, maximum design moment = 48750×10^3 Nmm
 Design axial load = $140 \times 10^3 + 75 \times 10^3 = 215 \times 10^3$ N

Assuming allowable axial compressive stress $\sigma_{ac} = 70 \text{ N/mm}^2$,

$$\begin{aligned}
 A &= \frac{215 \times 10^3}{70} \\
 &= 3071.42 \text{ mm}^2
 \end{aligned}$$

Let area thus calculated be increased by 100% to account for bending moment.

$$\text{Area} = 2 \times 3071.42 = 6142.85 \text{ mm}^2$$

From I.S. Handbook No. 1 select a suitable section furnishing cross-sectional area next to the value of area as calculated above. Provide I.S.H.B. 250 @ 500.3 N/m. The relevant properties of the section are,

$$\begin{aligned}
 A &= 6496 \text{ mm}^2, r_{xx} = 109.1 \text{ mm}, Z_{xx} = 618.9 \times 10^3 \text{ mm}^3 \\
 r_{yy} &= \text{Minimum radius of gyration}, r = 54.9 \text{ mm},
 \end{aligned}$$

$$\frac{l}{r} = \frac{8000}{54.9} = 145.719 < 180$$

$$\text{For } \frac{l}{r} = 145.719 \text{ and } f_y = 250 \text{ MPa,}$$

$$\sigma_{ac} = 49.84 \text{ N/mm}^2$$

$$\text{Now, } \frac{T}{t} = \frac{9.7}{6.9} = 1.4 < 2$$

$$\text{and } \frac{D}{T} = \frac{250}{9.7} = 25.7$$

For $\frac{D}{T} = 25.7$ and $\frac{l}{r} = 145.719$, from Table 7.1-B of the text,

$$\sigma_{bc} = 99.3 \text{ N/mm}^2$$

$$\sigma_{ac, cal} = \frac{215 \times 10^3}{6496} = 33.097 \text{ N/mm}^2$$

$$\sigma_{bc, cal} = \frac{48,750 \times 10^3}{618.9 \times 10^3} = 78.768 \text{ N/mm}^2$$

$$\frac{\sigma_{ac, cal}}{\sigma_{ac}} = \frac{33.097}{49.84} = 0.664 > 0.15$$

The interaction formula to be used for checking the safety is

$$\frac{\sigma_{ac, cal}}{\sigma_{ac}} + \frac{C_{mx} \sigma_{bcx, cal}}{\left\{ 1 - \frac{\sigma_{ac, cal}}{0.60 f_{ccx}} \right\} \sigma_{bcx}} \leq 1$$

The bending of the column takes place about x -axis as the eccentricity of the load is about x -axis. Therefore, the slenderness ratio in the plane of bending = $\frac{l}{r_{xx}}$
 $= \frac{8000}{109.1} = 73.32$

The ends of the column are hinged, therefore,

$$C_{mx} = 1.0$$

$$f_{ccx} = \frac{\pi^2 E}{\lambda^2} = \frac{\pi^2 \times 2 \times 10^5}{73.32^2} = 367.18 \text{ N/mm}^2$$

$$\frac{33.097}{49.84} + \frac{1 \times 78.768}{\left\{ 1 - \frac{33.097}{0.6 \times 367.18} \right\} \times 99.3} = 1.598 > 1$$

which is unsafe.

Try another section I.S.H.B. 400 @ 759.3 N/m. The relevant properties of the section are,

$$A = 9866 \text{ mm}^2, r_{yy} = 52.6 \text{ mm}, r_{xx} = 168.7 \text{ mm}, z_{xx} = 1404.2 \times 10^3 \text{ mm}^3$$

Minimum radius of gyration, $r = 52.6 \text{ mm}$

$$\frac{l}{r} = \frac{8000}{52.6} = 152.0913$$

For $\frac{l}{r} = 152.0913$, and $f_y = 250 \text{ MPa}$,

$$\sigma_{ac} = 44.16 \text{ N/mm}^2$$

Now,

$$\frac{T}{t} = \frac{12.7}{9.1} = 1.4$$

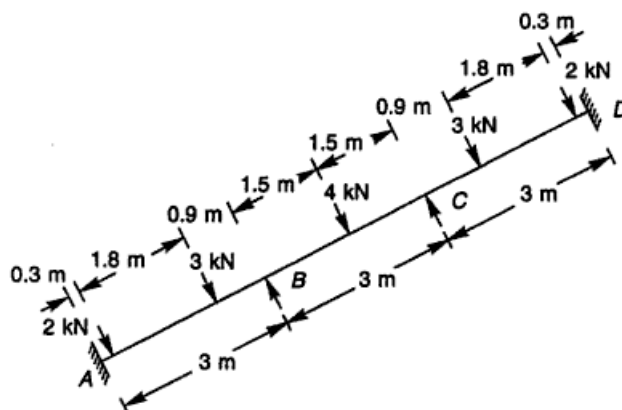

Fig. Ex. 4.12(a)

$$M_{FBA} = + \left\{ \frac{2 \times 0.3^2 \times 2.7}{3^2} + \frac{3 \times 2.1^2 \times 0.9}{3^2} \right\}$$

$$= +1.377 \text{ kNm}$$

$$M_{FBC} = - \frac{WL}{8} = - \frac{4 \times 3}{8} = -1.5 \text{ kNm}$$

$$M_{FCB} = +1.5 \text{ kNm}$$

By symmetry, $M_{FCD} = -1.377 \text{ kNm}$ and $M_{FDC} = 1.053 \text{ kNm}$

Distribution factors Assuming the moment of inertia to be constant throughout the rafter,

$$K_{BA} = \frac{I}{L} = \frac{I}{3}$$

$$K_{BC} = \frac{I}{L} = \frac{I}{3}$$

$$K_{CB} = \frac{I}{L} = \frac{I}{3}$$

$$K_{CD} = \frac{I}{L} = \frac{I}{3}$$

$$\text{Distribution factor for } BA = \frac{K_{BA}}{K_{BA} + K_{BC}} = \frac{\frac{I}{3}}{\frac{I}{3} + \frac{I}{3}} = 0.5$$

Similarly distribution factors, for $BC = 0.5$, $CB = 0.5$, and $CD = 0.5$

Joint	A	B		C		D
Distribution factor		0.5	0.5	0.5	0.5	
Member	AB	BA	BC	CB	CD	DC
F.E.M	-1.053	1.377	-1.5	1.5	-1.377	1.053
Balance		0.062	0.062	-0.062	-0.062	
Carry over	0.031		-0.031	0.031		-0.031
Balance		0.016	0.016	-0.016	-0.016	
Carry over	0.008		-0.008	0.008		-0.008
Balance		0.004	0.004	-0.004	-0.004	
Moments	-1.014	1.458	-1.458	1.458	-1.458	+1.014

Maximum positive bending moment = $3.00 - 1.458 = 1.542$ kNm

Maximum negative bending moment = 1.458 kNm

∴ Design moment = 1.542 kNm

The bending moment diagram for the rafter is shown in Fig. Ex. 4.12(b).

Forces The strut is subjected to

Axial compressive force = 100 kN

Bending moment = 1.542 kNm

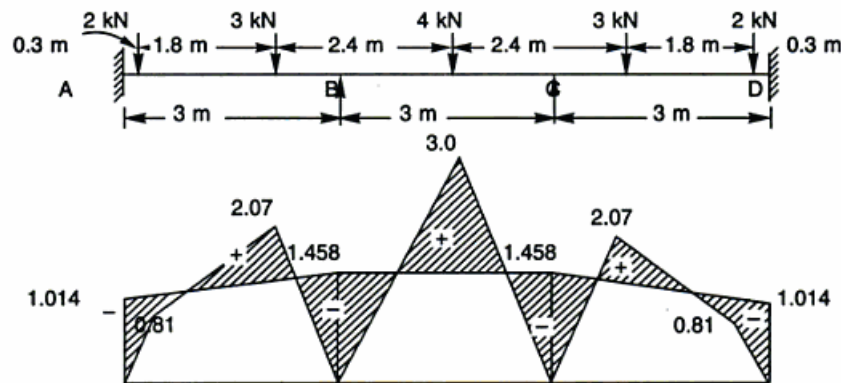

Fig. Ex. 4.12(b)

Assume allowable axial compressive stress = 60 N/mm²

$$A = \frac{100 \times 10^3}{60} = 1666.66 \text{ mm}^2$$

Increase the area by 50% to account for the bending moment

$$\text{Area} = 1.5 \times 1666.66 = 2499.99 \text{ mm}^2$$

If a single angle section is provided it will bend about an axis other than the xx -axis and it is difficult and time consuming to determine the axis of bending due to the effect of the gussets at the panel point and connections at the purlin points. If a double angle section is provided, there will be bending about the xx -axis (in the vertical plane). Therefore let us provide a double angle section (tack riveted).

Provide 2 I.S.A. $70 \times 70 \times 10$ mm. The properties of the angles are,

156 Design of Steel Structures

$$A = 2604 \text{ mm}^2, W = 200.2 \text{ N/m}, r_{xx} = 21.0 \text{ mm}, r_{yy} = 29.7 \text{ mm}, Z_{xx} = 23.4 \times 10^3 \text{ mm}^3$$

$$\begin{aligned} \text{Effective length } l_{xx} &= 0.7 \times \text{panel length} \\ &= 0.7 \times 3 \times 10^3 \text{ mm} \end{aligned}$$

$$\begin{aligned} \text{Effective length } l_{yy} &= 1.0 \times \text{distance between purlins} \\ &= 1.0 \times 2.4 \times 10^3 \text{ mm} \end{aligned}$$

$$\frac{l_x}{r_{xx}} = \frac{0.7 \times 3 \times 10^3}{21} = 100 < 350$$

$$\frac{l_y}{r_{yy}} = \frac{1 \times 2.4 \times 10^3}{29.7} = 80.8 < 350$$

For $\frac{l}{r} = 100$ and $f_y = 250 \text{ MPa}$,

$$\sigma_{ac} = 80 \text{ N/mm}^2$$

$$\sigma_{bc} = 0.66 \times 250 = 165 \text{ N/mm}^2$$

(Full allowable bending compressive stress $0.66 f_y$ is considered when the table of the angle section is in compression.)

$$\sigma_{ac, \text{cal}} = \frac{100 \times 10^3}{2604} = 38.40 \text{ N/mm}^2$$

$$\sigma_{bc, \text{cal}} = \frac{1542 \times 10^3}{23.4 \times 10^3} = 65.89 \text{ N/mm}^2$$

$$\frac{\sigma_{ac, \text{cal}}}{\sigma_{ac}} = \frac{38.4}{80} = 0.48 > 0.15$$

Check

$$\frac{\sigma_{ac, \text{cal}}}{\sigma_{ac}} + \frac{C_{mx} \sigma_{bcx, \text{cal}}}{\left\{1 - \frac{\sigma_{ac, \text{cal}}}{0.6 f_{ccx}}\right\} \sigma_{bcx}} \leq 1.0$$

$$f_{ccx} = \frac{\pi^2 E}{\lambda^2} = \frac{\pi^2 \times 2 \times 10^5}{(100)^2} = 197.4$$

$$\therefore \frac{38.4}{80} + \frac{0.85 \times 65.89}{\left\{1 - \frac{38.4}{0.6 \times 197.4}\right\} \times 165} = 0.98 < 1$$

which is safe.

Example 4.13 A stanchion in a building supports beams from three sides. The reactions from the beams are transferred at the eccentricities as shown in Fig. Ex. 4.13. The effective length of the column is 3.5 m. Design the column section. $f_y = 250 \text{ N/mm}^2$.

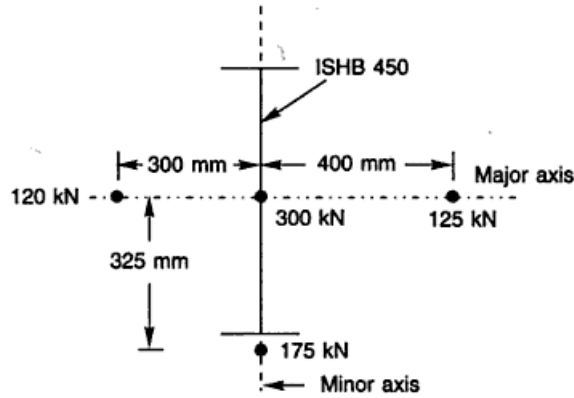

Fig. Ex. 4.13

Solution For the sections having $I_{yy} < I_{xx}$, the bending stresses about the major axis (xx -axis) are reduced to account for lateral instability whereas the bending stresses about the minor axis are taken as the maximum bending compressive stresses.

Assume allowable axial compressive stress as 85 N/mm^2 .

$$P = 300 + 120 + 175 + 125 = 720 \text{ kN}$$

$$A = \frac{720 \times 10^3}{85} = 8470 \text{ mm}^2$$

As the column is subjected to bending moments, the area computed above is increased, say by 25%, to account for the bending moments.

$$\text{Area} = 1.25 \times 8470 = 10588 \text{ mm}^2$$

From I.S. Handbook No. 1, select I.S.H.B. 450 @ 855.4 N/m.

The relevant properties of this section are

$$A = 11114 \text{ mm}^2, Z_{xx} = 1742.7 \times 10^3 \text{ mm}^3, Z_{yy} = 238.8 \times 10^3 \text{ mm}^3,$$

$$B = 250 \text{ mm}, T = 13.7 \text{ mm}, t = 9.8 \text{ mm}, D = 450 \text{ mm}, r_{yy} = 51.8 \text{ mm}, \text{ and } r_{xx} = 187.8 \text{ mm}$$

$$\text{Bending moment about } xx\text{-axis, } M_{xx} = 175 \times 325 = 56875 \text{ kNmm}$$

$$\text{Bending moment about } yy\text{-axis, } M_{yy} = 125 \times 400 - 120 \times 300 = 14,000 \text{ kNmm}$$

$$\sigma_{ac, \text{cal}} = \frac{720 \times 10^3}{11,114} = 64.78 \text{ N/mm}^2$$

$$\sigma_{bcx, \text{cal}} = \frac{M_{xx}}{Z_{xx}} = \frac{56875 \times 10^3}{1742.7 \times 10^3} = 32.6361 \text{ N/mm}^2$$

$$\sigma_{bcy, \text{cal}} = \frac{M_{yy}}{Z_{yy}} = \frac{14,000 \times 10^3}{238.8 \times 10^3} = 58.6264 \text{ N/mm}^2$$

Now, $\frac{T}{t} = \frac{13.7}{9.8} = 1.397 < 2$

and $\frac{d_1}{t} = \frac{450 - (2 \times 13.7)}{9.8} = 43.12 < 85$

So, $\frac{T}{t} < 2$ and $\frac{d_1}{t} < 85$

Now, $\frac{D}{T} = \frac{450}{13.7} = 32.8467$

and $\frac{l}{r_{yy}} = \frac{3500}{51.8} = 67.56$

For $\frac{D}{T} = 32.8467$ and $\frac{l}{r_{yy}} = 67.56$, from Table 7.1-B of the text,

$$\sigma_{bcx} = 144.172 \text{ N/mm}^2$$

and $\sigma_{bcy} = 0.66 f_y = 0.66 \times 250 = 165 \text{ N/mm}^2$

For $\frac{l}{r} = 67.56$, and $f_y = 250 \text{ MPa}$,

$$\sigma_{ac} = 114.44 \text{ N/mm}^2$$

$$\frac{\sigma_{ac, \text{cal}}}{\sigma_{ac}} = \frac{64.78}{114.44} = 0.566 > 0.15$$

Check,
$$\frac{\sigma_{ac, \text{cal}}}{\sigma_{ac}} + \frac{C_{mx} \sigma_{bcx, \text{cal}}}{\left\{1 - \frac{\sigma_{ac, \text{cal}}}{0.6 f_{ccx}}\right\} \sigma_{bcx}} + \frac{C_{my} \sigma_{bcy, \text{cal}}}{\left\{1 - \frac{\sigma_{ac, \text{cal}}}{0.6 f_{ccy}}\right\} \sigma_{bcy}} \leq 1$$

Assume $C_{mx} = 0.85$

and $C_{my} = 0.45$

$$\frac{l}{r_{xx}} = \frac{3500}{187.8} = 18.63$$

$$f_{ccx} = \frac{\pi^2 \times 2 \times 10^5}{18.63^2} = 5681.5 \text{ N/mm}^2$$

$$\frac{l}{r_{yy}} = 67.56$$

$$f_{ccy} = \frac{\pi^2 \times 2 \times 10^5}{67.56^2} = 432.0 \text{ N/mm}^2$$

$$\therefore \frac{64.78}{114.44} + \frac{0.85 \times 32.6361}{\left\{1 - \frac{64.78}{0.6 \times 5681.5}\right\} \times 144.172} + \frac{0.45 \times 58.6264}{\left\{1 - \frac{64.78}{0.6 \times 432}\right\} \times 165} = 0.975 < 1$$

which is safe.

Example 4.14 A column I.S.H.B 300 @ 618 N/m in a Hi-rise building supports beams from two sides as shown in Fig. Ex. 4.14. The beams are welded to the column flanges and transfer end reactions of 150 kN (Beam 1) and 250 kN (Beam 2) and an axial compressive force of 450 kN from the top storeys. Check the safety of the column if its effective length is 3.2 m. Assume, $C_{mx} = 0.85$ and $f_y = 250 \text{ N/mm}^2$.

Solution Load passing through the centre of gravity of the section, $P = 450 + 150 + 250 = 850 \text{ kN}$

From I.S. Handbook No. 1, the relevant properties of I.S.H.B 300 @ 618 N/m are

$$A = 8025 \text{ mm}^2, Z_{xx} = 863.3 \times 10^3 \text{ mm}^3, B = 250 \text{ mm}, \\ T = 10.6 \text{ mm}, D = 300 \text{ mm}, t = 9.4 \text{ mm}, \\ r_{xx} = 127.0 \text{ mm}, \text{ and } r_{yy} = 52.9 \text{ mm}$$

$$M_{xx} = 250 \times \frac{300}{2} - 150 \times \frac{300}{2} = 15000 \text{ kN mm}$$

$$\sigma_{ac, \text{cal}} = \frac{850 \times 10^3}{8025} = 105.91 \text{ N/mm}^2$$

$$\sigma_{bcx, \text{cal}} = \frac{M_{xx}}{Z_{xx}} = \frac{15000 \times 10^3}{863.3 \times 10^3} = 17.37 \text{ N/mm}^2$$

Now, $\frac{T}{t} = \frac{10.6}{9.4} = 1.127$

and $\frac{d_1}{t} = \frac{300 - (2 \times 10.6)}{9.4} = 29.66 < 85$

Now, $\frac{D}{T} = \frac{300}{10.6} = 28.30$

and $\frac{l}{r_{yy}} = \frac{3.2 \times 10^3}{52.9} = 60.49$

For $\frac{D}{T} = 28.30$ and $\frac{l}{r_{yy}} = 60.49$, from Table 7.1B of the text,

$$\sigma_{bcx} = 149.046 \text{ N/mm}^2$$

For $\frac{l}{r} = 60.49$ and $f_y = 250 \text{ N/mm}^2$,

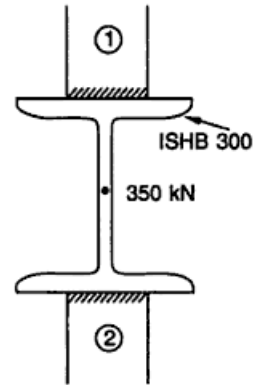

Fig. Ex. 4.14

$$\sigma_{ac} = 121.51 \text{ N/mm}^2$$

$$f_{ccx} = \frac{\pi^2 \times 2 \times 10^5}{(3200/127)^2} = 3109.12 \text{ N/mm}^2$$

Check

$$\frac{\sigma_{ac, cal}}{\sigma_{ac}} + \frac{C_{mx} \sigma_{bcx, cal}}{\left\{ 1 - \frac{\sigma_{ac, cal}}{0.6 f_{ccx}} \right\} \sigma_{bcx}} \leq 1$$

or

$$\frac{105.91}{121.51} + \frac{0.85 \times 17.37}{\left\{ 1 - \frac{105.91}{0.6 \times 3109} \right\} \times 149.046} = 0.9766 < 1$$

which is safe.

Example 4.15 Design a cased column to carry an axial load of 1100 kN. The column is 5 m long and restrained in position and direction at both ends. Use M-15 grade of concrete.

Solution Assume allowable compressive stress 110 MPa,

$$\text{Cross-sectional area required} = \frac{1100 \times 1000}{110} = 10,000 \text{ mm}^2$$

Select I.S.H.B. 450 @ 855.4 N/m from I.S. Handbook No. 1.

$$A = 11114 \text{ mm}^2, Z_{xx} = 1742.7 \times 10^3 \text{ mm}^3, B = 250 \text{ mm}$$

$$\text{Minimum radius of gyration} = 51.8 \text{ mm}$$

Now,

$$l = 0.65L$$

$$= 0.65 \times 1000 \times 5 = 3250 \text{ mm}$$

Uncased column

$$\frac{l}{r} = \frac{3250}{51.8} = 62.74 < 250$$

which is all right.

For $\frac{l}{r} = 62.74$ and $f_y = 250 \text{ MPa}$,

$$\sigma_{ac} = 119.256 \text{ N/mm}^2$$

$$\begin{aligned} \text{Load carrying capacity} &= 119.256 \times 11,114 \\ &= 1,325,411.2 \text{ N} = 1325.411 \text{ kN} \end{aligned}$$

which is all right.

Cased column Column size is 550 mm × 350 mm. The column is encased in concrete with a 50 mm cover all around.

$$\begin{aligned} r_{yy} &= 0.2(B + 100) \\ &= 0.2(250 + 100) = 0.2 \times 350 = 70 \text{ mm} \end{aligned}$$

$$\frac{l}{r} = \frac{3250}{70} = 46.428$$

For $\frac{l}{r} = 46.428$ and $f_y = 250$ MPa

$$\sigma_{ac} = 134.500 \text{ N/mm}^2$$

$$\begin{aligned} \text{Load carrying capacity} &= 134.500 \times 11,114 = 1,494,833.0 \text{ N} \\ &= 1494.833 \text{ kN} < 2 \times 1325.411 \text{ kN} \end{aligned}$$

which is safe.

Allowable safe load on column treating it as a reinforced column,

$$\text{Steel area} = 11,114 \text{ mm}^2$$

$$\begin{aligned} \text{Concrete area} &= (550 \times 350 - 11,114) \\ &= 181,386 \text{ mm}^2 \end{aligned}$$

$$\begin{aligned} \text{Allowable safe load} &= \text{safe load on uncased column} \\ &\quad + \text{safe load on concrete} \\ &= 119.256 \times 11,114 + 181,386 \times 3.75 \\ &\quad \quad \quad (0.25 f_{ck} = 0.25 \times 15 = 3.75) \\ &= 2005.60 \text{ kN} \\ &> \text{load carrying capacity of cased column} \end{aligned}$$

which is safe.

Example 4.16 Design a built up column 10 m long to carry an axial load of 750×10^3 N. The column is restrained in position but not in direction at both the ends. Provide single lacing system with riveted connections. Assume $f_y = 250$ MPa.

- Design the column with two channels placed back-to-back
- Design the column with two channels placed toe-to-toe
- Which of the two systems is economical
- Design the lacing system with welded connections for channels back-to-back.

Solution

Design of column

$$P = 750 \times 10^3 \text{ N}$$

$$l = 1.0 \times 10 = 10 \text{ m}$$

Let the allowable axial compressive stress for the column be 110 MPa.

$$\begin{aligned} \text{Cross-sectional area required} &= \frac{P}{\text{allowable axial compressive stress}} \\ &= \frac{750 \times 10^3}{110} = 6818 \text{ mm}^2 \end{aligned}$$

Select I.S.M.C. 250 @ 298.2 N/m, 2 in numbers from I.S. Handbook No. 1.

The relevant properties of I.S.M.C. 250 @ 298.2 N/m are,

$$A = 3867 \text{ mm}^2, r_{xx} = 99.4 \text{ mm}, r_{yy} = 23.8 \text{ mm}, \text{ and } T = 14.1 \text{ mm}$$

$$\text{Area provided} = 2 \times 3867 = 7734 \text{ mm}^2$$

In the design of built-up columns with two sections, the sections are so spaced that the least radius of gyration of the built up section becomes as large a value as possible. Therefore, the radius of gyration about yy-axis is increased so that it becomes equal to or more than the radius of gyration about xx-axis. This can be

achieved by spacing the sections in such a way that r_{xx} becomes r_{min} . Therefore, let us first check the safety of the section after which its spacing can be worked out.

$$\frac{l}{r} = \frac{10 \times 10^3}{99.4} = 100.6036$$

For $\frac{l}{r} = 100.6036$, and $f_y = 250$ MPa,

$$\sigma_{ac} = 79.517 \text{ N/mm}^2$$

$$\begin{aligned} \text{Load carrying capacity} &= 79.517 \times 7734 = 614,984.47 \text{ N} \\ &= 614.984 \text{ kN} < \text{load over section} \end{aligned}$$

which is not safe.

Try I.S.M.C. 300 @ 351.2 N/m, 2 in numbers. The relevant properties are,

$$\begin{aligned} A &= 4564 \text{ mm}^2, r_{xx} = 118.1 \text{ mm}, r_{yy} = 26.1 \text{ mm}, C_{yy} = 23.6 \text{ mm}, \\ I_{xx} &= 6362.6 \times 10^4 \text{ mm}^4, I_{yy} = 310.8 \times 10^4 \text{ mm}^4, g = 50 \text{ mm} \end{aligned}$$

$$\text{Area provided} = 2 \times 4564 = 9128 \text{ mm}^2$$

$$\frac{l}{r} = \frac{10 \times (10)^3}{118.1} = 84.6740$$

For $\frac{l}{r} = 84.6740$, and $f_y = 250$ MPa,

$$\sigma_{ac} = 95.863 \text{ N/mm}^2$$

$$\begin{aligned} \text{Load carrying capacity} &= 95.863 \times 9128 \times 10^{-3} \\ &= 875.037 \text{ kN} > \text{load over the section} \end{aligned}$$

which is safe,

(a) Let us provide the two channels back-to-back and connect them by lacing.

Spacing of channels

$$2I_{xx} = 2 \left\{ I_{yy} + A \left(\frac{S}{2} + C_{yy} \right)^2 \right\}$$

$$\text{or} \quad 2 \times 6362.6 \times 10^4 = 2 \times \left\{ 310.8 \times 10^4 + 4564 \left(\frac{S}{2} + 23.6 \right)^2 \right\}$$

$$\text{or} \quad \left(\frac{S}{2} + 23.6 \right)^2 = 13,259.859$$

$$S = 183.10 \text{ mm}$$

Let us place the two channels at a spacing of 183.5 mm (Fig. Ex. 4.16(i)).

Lacing system Let us try the single lacing system.

Assume the inclination of lacing bar = 45°

$$\begin{aligned} \text{Spacing of lacing bars, } C &= 2(183.5 + 50 + 50) \cot 45^\circ \\ &= 2 \times 283.5 \times 1 = 567 \text{ mm} \end{aligned}$$

$$\frac{C}{r_{yy}} = \frac{567}{26.1} = 21.724 < 50$$

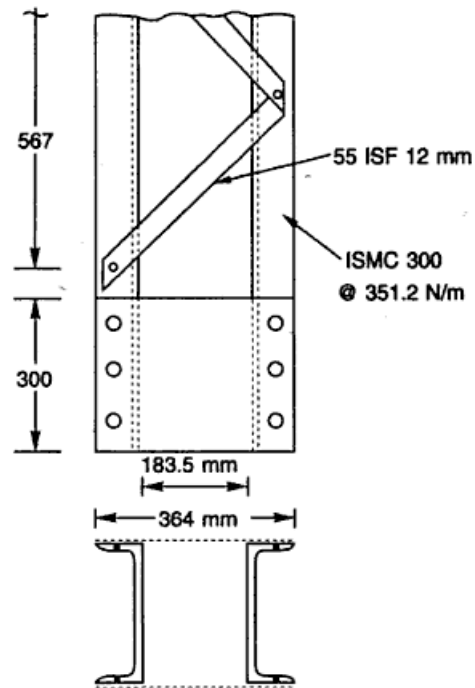
Fig. Ex. 4.16(i)

Also C/r_y , should be $< 0.7 \times 84.674 (= 59.2718)$, which it is.

$$\text{Maximum shear, } V = \frac{2.5}{100} \times 750 \times 10^3 = 18,750 \text{ N}$$

$$\text{Transverse shear in each pannel} = \frac{V}{N} = \frac{1}{2} \times 18,750 = 9375 \text{ N}$$

$$\begin{aligned} \text{Compressive force in lacing bars} &= \frac{V}{N} \operatorname{cosec} \theta \\ &= 9375 \times \operatorname{cosec} 45^\circ = 13,258.379 \text{ N} \end{aligned}$$

Lacing flats Let us provide 18 mm ϕ power driven rivets.

$$\text{Gross diameter of rivet} = 18 + 1.5 = 19.5 \text{ mm}$$

For 18 mm ϕ rivets, width of lacing flat as specified by I.S. Code is 55 mm (Table 4.5 of the text).

$$\begin{aligned} \text{Minimum thickness of lacing flat} &= \frac{1}{40} \times \text{length of flat between inner end rivets.} \\ &= \frac{1}{40} (183.5 + 50 + 50) \operatorname{cosec} 45^\circ \\ &= 10.02 \text{ mm} \approx 12 \text{ mm} \end{aligned}$$

Provide a flat section 55 I.S.F. 12 mm.

$$\text{Minimum radius of gyration, } r = \frac{t}{\sqrt{12}} = \frac{12}{\sqrt{12}} = 3.464 \text{ mm}$$

$$\frac{l}{r} = \frac{283.5 \times \operatorname{cosec} 45^\circ}{3.464} = 115.72 < 145$$

which is all right.

For $\frac{l}{r} = 115.72$ and $f_y = 250$ MPa,

$$\sigma_{ac} = 67.424 \text{ N/mm}^2$$

$$\begin{aligned} \text{Load carrying capacity} &= 67.424 \times 55 \times 12 = 44,499.8 \text{ N} \\ &= 44.49 \text{ kN} > 13.258 \text{ kN} \end{aligned}$$

which is sufficient.

$$\begin{aligned} \text{Tensile strength of lacing flat} &= (B - d)t\sigma_{at} \\ &= (55 - 19.5) \times 12 \times (0.6 \times 250) \\ &= 63,900 \text{ N} = 63.9 \text{ kN} > 13.258 \text{ kN} \end{aligned}$$

which is safe.

Connection Assuming that one 18 mm ϕ power rivet is used to connect both the lacing flats with channel at one point as shown in Fig. Ex. 4.16(i).

$$\begin{aligned} \text{Strength of the rivet in double shear} &= 2 \times \frac{\pi}{4} d^2 \tau_{vf} \\ &= 2 \times \frac{\pi}{4} 19.5^2 \times 100 = 59729 \text{ N} \end{aligned}$$

$$\begin{aligned} \text{Strength of the rivet in bearing} &= dt \sigma_{pf} = 19.5 \times 12 \times 300 \\ &= 70,200 \text{ N} \end{aligned}$$

$$\therefore \text{Strength of the rivet} = 59,729 \text{ N}$$

$$\begin{aligned} \text{Force on rivet from flat} &= 2 \frac{V}{N} \cot \theta \\ &= 2 \times 9.375 \times 10^3 \cot 45^\circ \\ &= 18.75 \times 10^3 \text{ N} \end{aligned}$$

$$\text{Number of rivets required} = \frac{18.75 \times 10^3}{59729} = 0.31 \approx 1$$

Provide one rivet to connect each end of the flat with channels.

The two lacing flats may be connected at different points with channel section as shown in Fig. 4.8(b). Rivets will be in single shear.

Strength of the rivet in single shear

$$= \frac{\pi}{4} d^2 \tau_{vf} = \frac{\pi}{4} 19.5^2 \times 100 = 29864.7$$

Strength of rivet in bearing

$$= dt \sigma_{pf} = 19.5 \times 12 \times 300 = 70,200 \text{ N}$$

Strength of rivet = 29864.7 N

$$\text{Force on rivet from flat} = \frac{V}{N} \operatorname{cosec} \theta = 13258.379 \text{ N}$$

$$\text{Number of rivets required} = \frac{13258.379}{29864.7} = 0.44 \approx 1$$

Provide 1 rivet to connect each end of the flat with channels.

Note The advantage of connecting each flat separately with the channel has been discussed in Section 4.9. However, this arrangement is costly since additional holes and rivets will be required. Therefore, any one of the above two system of connections may be used, depending upon the descretion of the designer. In the examples that follow the flats are connected at one point to achieve economy.

Tie plate Tie plates are provided at the ends of the laced column,

$$\text{Effective depth} = 183.5 + 2 \times 23.6 = 230.7 \text{ mm} > 2 \times 90 \text{ mm}$$

which is all right.

$$\begin{aligned} \text{Overall depth of tie plate} &= 230.7 + 2 \times 29 = 288.7 = 300 \text{ mm} \\ &\text{(minimum edge distance for 18 mm } \phi \text{ rivets} = 29 \text{ mm)} \end{aligned}$$

$$\text{Length of the tie plate} = 183.5 + 2 \times 90 = 364 \text{ mm}$$

$$\text{Thickness of the tie plate} = \frac{1}{50} (183.5 + 2 \times 50) = 5.67 \text{ mm} \approx 6 \text{ mm}$$

Provide a tie plate $364 \times 300 \times 6$ mm and connect it to the channels with 18 ϕ rivets.

(b) Let us provide the two channels toe-to-toe and connect them with lacing.

Spacing

$$2I_{xx} = 2 \left\{ I_{yy} + A \left(\frac{S}{2} - C_{yy} \right)^2 \right\}$$

$$\text{or} \quad 2 \times 6362.6 \times 10^4 = 2 \left\{ 310.8 \times 10^4 + 4564 \left(\frac{S}{2} - 23.6 \right)^2 \right\}$$

$$\text{or} \quad \left(\frac{S}{2} - 23.6 \right)^2 = 13,259.859$$

$$S = 277.50 \text{ mm} \approx 278 \text{ mm}$$

Let us place the channels at a spacing of 278 mm (Fig. Ex. 4.16(ii))

Connecting system Provide a single lacing system. Assume the inclination of the lacing bar be 45° .

$$C = 2(278 - 50 - 50) \cot 45^\circ = 356 \text{ mm}$$

$$\frac{C}{r_{yy}} = \frac{356}{26.1} = 13.6398 < 50$$

and should be $< 0.7 \times 84.674 (= 59.2718)$, which it is.

$$\text{Compressive force in lacing bar} = 13.258379 \times 10^3 \text{ N}$$

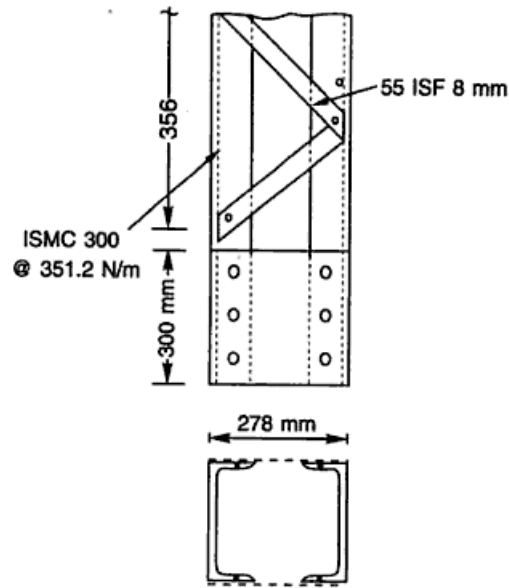

Fig. Ex. 4.16(ii)

Section of lacing flat Let us provide 18 mm ϕ rivets.

Gross diameter of rivet = 18 + 1.5 = 19.5 mm

Width of flat = 55 mm

$$\begin{aligned} \text{Thickness of flat} &= \frac{1}{40} (278 - 50 - 50) \times \operatorname{cosec} 45^\circ \\ &= 6.29 \text{ mm} \approx 8 \text{ mm} \end{aligned}$$

Provide 8 mm thick flat.

Check

$$r_{\min} = \frac{t}{\sqrt{12}} = \frac{8}{\sqrt{12}} = 2.309 \text{ mm}$$

$$\begin{aligned} \frac{l}{r} &= \frac{178 \operatorname{cosec} 45^\circ}{2.309} = 109 \\ &< 145 \end{aligned}$$

which is safe.

Provide 55 I.S.F. 8 mm flat section.

For $\frac{l}{r} = 109.00$ and $f_y = 250$ MPa,

$$\sigma_{ac} = 72.8 \text{ N/mm}^2$$

$$\begin{aligned} \text{Load carrying capacity} &= 72.8 \times 55 \times 8 = 32,032 \text{ N} = 32.03 \text{ kN} \\ &> 13.258 \text{ kN} \end{aligned}$$

which is safe.

Visual Walkthrough

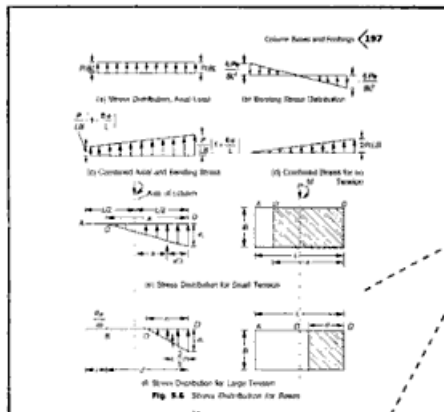

Fig. 5.6 Stress Distribution for Beams

Figures are used to give a pictorial view and to illustrate the arrangement of various elements. Diagrams are given for visualization of explanation.

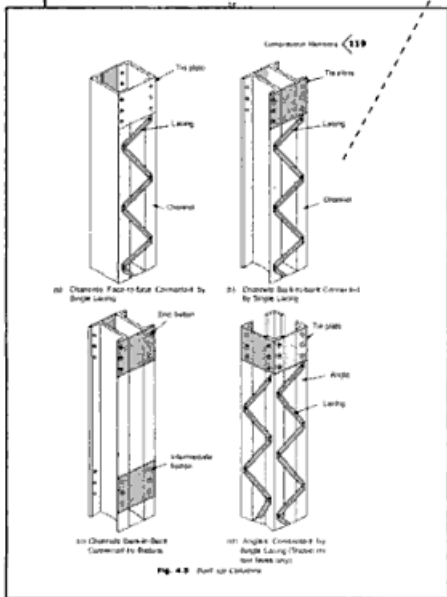

Fig. 4.9 Built-up Columns

A variety of typical Solved Examples are given to reinforce the concepts.

Tension Members <43

Try two L.S.A. 75 x 90 x 8 mm @ 145.2 N/m.

Net area = gross area - area of rivet hole
 $= 1876 - 2 \times 21.5 \times 8 = 1532 \text{ mm}^2$

Strength of the member = $1532 \times 150 \times 10^{-3} = 229.800 \text{ kN} > 200 \text{ kN}$

The section can be selected for economy.

Try 2 I.S.A. 30 x 45 x 8 mm @ 131.4 N/m.

$A = 1716 \text{ mm}^2, r = 21.9 \text{ mm}$

Net area provided = gross area - area of rivet hole
 $= 1716 - 2 \times 21.5 \times 8 = 1372 \text{ mm}^2$

Strength of the member = $1372 \times 150 \times 10^{-3} = 205.800 \text{ kN} > 200 \text{ kN}$

which is all right

$$\frac{f}{r} = \frac{3000}{21.9} = 136.98 < 150$$

It is to be noted that this section is the most economical, and stable. However, the cost of making extra holes and six tack rivets will have to be added to do the final estimation and selection.

Example 6.5 The lattice chord (tension member) of a roof truss is subjected to an axial pull of 300 kN. A differential chain-link arrangement is attached to the bottom chord and gives a point load of 30 kN at the centre. The length of the member between panel points is 4.0 m. Design the section assuming it has unequal angles with long legs back-to-back and laced equally. Assume $f_y = 250 \text{ N/mm}^2$.

Solution

Allowable axial tensile stress, $\sigma_{at} = 0.6 \times 250 = 150 \text{ N/mm}^2$

Net area required for axial pull = $\frac{300 \times 10^3}{150} = 2000 \text{ mm}^2$

Increase the net area by 50% to account for bending moment
 $= 1.5 \times 2000 = 3000 \text{ mm}^2$

A tentative gross area required = $1.4 \times 3000 = 4200 \text{ mm}^2$

Let us assume the section to be weakened by one rivet hole and let the diameter of rivet be 14 mm.

Try 2 I.S.A. 150 x 75 x 10 mm from I.S. Handbook No. 1 (equal legs back-to-back).

The relevant properties of the sections are:

$C_{xx} = 53.7 \text{ mm}^2, A = 4312 \text{ mm}^2, f_y = 995.2 \times 10^3 \text{ mm}^2$

Net area provided = $4312 - 2 \times 15.5 \times 10 = 4002 \text{ mm}^2$

$$\sigma_{at} = \frac{300 \times 10^3}{4002} = 74.96 \text{ N/mm}^2$$

$$\sigma_{at} < 140 \times 10^3 / C_{xx}$$

The McGraw-Hill Companies

DESIGN OF STEEL STRUCTURES

Third Edition

This edition of *Design of Steel Structures* has been revised extensively to bring in several new topics and introduce the most recent design methodologies. A plethora of solved examples and practice problems make this an excellent offering for students and practicing engineers alike.

Salient features

- New chapters on Limit State Design, Light Gauge Steel Construction, and Steel Sacks
- Exhaustive coverage of High Strength Friction Grip Bolts
- Prologue to the New Code IS: 800 2009
- Pedagogy
 - ⇒ 147 Solved examples
 - ⇒ 154 Review questions

Advance praise for the book:

"...This book provides extensive coverage of the topic for undergraduate students of various universities. The layout and figures in the book are particularly good. The large number of examples and practice problems are special features.."

URL: <http://www.mhhe.com/duggal/dss3e>

Visit us at : www.tatamcgrawhill.com



Tata McGraw-Hill

ISBN-13: 978-0-07-026068-9

ISBN-10: 0-07-026068-0



9 780070 260689

Copyrighted material

